

UNDERSTANDING HUMAN DESIGN

The New Science of Astrology:
Discover Who You Really Are



KAREN CURRY

KAREN CURRY
UNDERSTANDING
HUMAN
DESIGN



Hierophant publishing

Copyright © 2013

by Karen Curry

All rights reserved, including the right to reproduce this work in any form whatsoever, without permission in writing from the publisher, except for brief passages in connection with a review.

Cover design by Adrian Morgan Cover art © Shutterstock Author photo by Mindy Harmon Text design by Jane Hagaman
Hierophant Publishing

8301 Broadway, Suite 219

San Antonio, TX 78209

888-800-4240

www.hierophantpublishing.com

If you are unable to order this book from your local bookseller, you may order directly from the publisher.

Library of Congress Control Number: 2013944355

ISBN 978-1-938289-10-1

10 9 8 7 6 5 4 3 2 1

Printed on acid-free paper in the United States

www.redwheelweiser.com

www.redwheelweiser.com/newsletter

*For my children, Keegan, Kat, Karson, Cassidy, and Ayelet, who have
always been the guiding stars in my life.
And for Aaron, who always reminds me to dream bigger.
How could a girl get so lucky?*

Contents

[Preface](#)

[Acknowledgments](#)

[Introduction](#)

[Part One](#)

[The Basics of Human Design](#)

[1. Navigating Your Chart](#)

[*Setting the Stage*](#)

[*Navigating Your Chart*](#)

[*The Body Graph*](#)

[*The Birth Chart*](#)

[*The Keynotes*](#)

[*Summary*](#)

[Part Two](#)

[Types, Centers, and Profiles](#)

[2. The Five Personality Types](#)

[*The Manifestor*](#)

[*The Generator*](#)

[*The Manifesting Generator*](#)

[*The Projector*](#)

[*The Reflector*](#)

[*Authority*](#)

[3. The Nine Centers](#)

[*The First Center: The Head*](#)

[*The Second Center: The Ajna*](#)

[*The Third Center: The Throat*](#)

[*The Fourth Center: The Identity*](#)

[*The Fifth Center: The Will*](#)

The Sixth Center: The Emotional Solar Plexus

The Seventh Center: The Root

The Eighth Center: The Spleen

The Ninth Center: The Sacral

4. The Lines and Profiles

Understanding the Six Lines

The Lower Trigram: Intrapersonal Energy

Line 1: The Investigator

Line 2: The Hermit

Line 3: The Martyr

The Upper Trigram: Transpersonal Energy

Line 4: The Opportunist

Line 5: The Heretic

Line 6: The Role Model

The Twelve Profiles

Part Three

Gates, Circuits, and Channels

5. The Gates

Gates 1–20

Gates 21–40

Gates 41–64

6. The Major Circuits

The Individual Circuit

The Tribal Circuit

The Collective Circuit

7. The Individual Subcircuits

The Integration Circuit

The Centering Circuit

The Knowing Circuit

8. The Tribal Subcircuits

[*The Defense Circuit*](#)

[*The Ego Circuit*](#)

[9. The Collective Subcircuits](#)

[*The Logic Circuit*](#)

[*The Sensing Circuit*](#)

[Part Four](#)

[Putting It All Together](#)

[10. The Sum of Your Parts](#)

[*A Sneak Peak into the Future*](#)

[Resources](#)

Preface

Have you ever wondered what makes you unique from the other people around you? Human Design, a synthesis of ancient wisdom and modern science, can help you understand the beauty and the power of just who you really are.

I first encountered Human Design in 2001 when my husband brought home a Human Design chart from Sedona, Arizona, where he had been on a personal retreat. I was smitten by the chart and knew I had to learn everything I could about it. I immediately persuaded my husband to move with our four kids from our comfortable suburban home in Texas to Sedona, where I hoped to learn more about Human Design.

As luck would have it, I found the home office for Human Design America directly across the hall from our pediatrician's office in Sedona. I immediately recognized the Human Design body graph on the office door and walked in to get more information. The owner of the office, Mary Ann Winiger, was in the process of writing a want ad for office help when I walked in, and she asked me if I'd like the job. I responded with a resounding yes and started right away. Working for Human Design America gave me easy access to all the information available at the time, and I had the opportunity to study with the founder of the system, Ra Uru Hu.

I admit, in the beginning, I was uncomfortable with the esoteric origin of Human Design. I was raised in the South, and my former father-in-law was a Methodist minister. Astrology and other “woo-woo” tricks were supposedly works of the devil, and I was very nervous about using these methods on myself or with my life-coaching clients. But the system proved to be uncannily accurate.

I believe that most people who are looking for help and support are usually on a quest, because they are hurting in some area of their lives—career, relationships, health, creative fulfillment, or feeling spiritually connected with life. I understood intuitively that Human Design provided answers for people who are hurting, but I wasn't comfortable sharing that knowledge until I had applied it and experimented with it in my own life. After testing it on myself and getting wonderful results, I started running charts for everyone in my life, including my clients. At the time, I was using the Emotional Freedom Technique (EFT) quite a bit with my clients, especially if they felt “stuck.” To my surprise, the Human Design chart gave me such incredible insights into the

energetic roots of my clients' “stuckness” and their personality traits that I was able to dramatically improve their lives in much shorter periods of time.

The more I studied Human Design, the more I realized that in spite of its incredible benefits, it was not a system that was easy to share with others. It was burdened by complex and esoteric vocabulary that left a lot of newbies confused. While there are many layers to the Human Design system, and I'm still learning more even after twelve years of experience, there are some core concepts that are pretty easy to pick up and apply. That's why I wanted to write this book—to get you up and running with a wonderful system that has helped not only me and my family, but hundreds of my clients as well. I hope you'll join me on this journey of self-discovery and positive change.

Acknowledgments

This book has been thirteen years in the making. It is the compilation of my cognitive understanding of Human Design and the synthesis of my own experience of discovering my true self. I could not have endured this journey without the love and support of my family, who still hopes that some day I'll get a “real” job.

I have to thank Kyle Curry, my ex-husband and good friend, for patiently piecing together all the different parts of my writing creations into one body of information. I also have to thank him for always holding a space for me to share this information in a powerful and impactful way.

None of this information would be in the world today if it weren't for my teacher, Ra Uru Hu. Ra was a reluctant mystic at best. But in spite of his hesitancy and struggles, he shared Human Design because he had no choice. Ra initiated us into a new awareness of our unique roles in fostering the evolution of humankind, showing us that the most powerful thing you can do in life is to love yourself first.

I have experimented with all of this information on my students, who, over the years, have taught me more than I ever taught them. Thank you for being so eager to share Human Design with the world and for letting me be your teacher. It is a tremendous honor.

My editors, Allison Jacob and Susie Pitzen, have, judging from all the marks on the copyedited manuscript, spent a good bit of their lives making this giant body of complex data a coherent instruction manual of self-discovery. Thanks for your patience and endurance!

And last, but definitely not least, thank you to my partner, Aaron Parker, and my five children, who have always believed in me and inspired me to keep going.

Introduction

It is my honor to support you in discovering your life purpose, understanding yourself, improving your relationships, finding your right work, and even getting healthier—easily and without compromising who you are! Human Design gives you the information you need to start living joyfully and intentionally, to find strength and abundance so you can thrive no matter what's going on around you. Over the last thirteen years, I have produced thousands of Human Design charts and conducted more than a thousand readings—all with the same powerful results. And I want to introduce you to this incredible system.

Human Design has helped people learn to love themselves, improve their self-esteem, live authentically, and act with awareness, deliberation, and courage. With Human Design you learn to leverage your energy correctly to avoid becoming overwhelmed, despairing, and burned out. Human Design shows you how you understand and “know” things (hint: it's okay to not always be logical), and it teaches you how to honor and express your feelings so you are never a victim of emotional pain and suffering again.

A synthesis of astrology, the I Ching, Kabbalah, the chakra system, and quantum physics, Human Design is a relatively new science of self-discovery. The entire system was transmitted to Robert Alan Krakower during a mystical experience in Ibiza, Spain, from January 3–11, 1987. A voice told him that this system was crucial to helping people on the planet make vital shifts in consciousness for the evolution of mankind. Krakower emerged from this experience a changed man, and soon after he changed his name to Ra Uru Hu.

Ra was told that while he was one of few people who consciously received the information about Human Design, the energy of the system was transmitted to all of us, and it belongs to all of humanity. He was a reluctant messenger and mystic at best, but he spent the rest of his life sharing the theory of Human Design. His courage has helped people discover who they really are, what they are here to do, and how they can go about living an authentic and abundant life.

Human Design is not a religion. It doesn't matter whether you come from a Christian, Jewish, Buddhist, or metaphysical background. Knowing your Human Design simply helps you know how to become the person you were created to be in an easy and joyful way.

Though the Human Design system is complex, and it can take years to learn how to create a body graph and chart on your own, the ideas behind the system

are actually pretty simple. Your personal Human Design body chart, calculated from your birth data, gives you very specific knowledge about your personality traits, your health, your personal psychology, your talents, your wisdom, and your vulnerabilities. Once you discover your unique energies, and you are able to differentiate between the energy you create versus the energy you absorb from the world around you, you can start immediately making powerful decisions that will help you create a life that is in alignment with who you truly are.

Through the chapters in this book, I will show you how you can realize your inner authority about what is correct for your unique life. In [part 1](#), we will cover the basics of Human Design—what it is and how you can begin to read your chart to effect change in your life from day one. In [part 2](#), we'll look at types, centers, and profiles. These are three key aspects of Human Design. In [part 3](#), we'll dig deeper and cover gates, circuits, and channels—the inner workings of your personality. And in [part 4](#), we'll put it all together and go out into the world with this new perspective.

Human Design is not about changing yourself. It simply gives you the tools to journey back to a deeper understanding of your gifts, your wisdom, your drive, and your vulnerabilities, which can set you free from old, self-defeating patterns of thinking and the judgment of others. It gives you a new perspective so you can see the beauty and magnificence of who you truly are.

When you understand yourself, you can make choices about your life that are in alignment with your true nature. When you work with your true nature, your life becomes a much smoother ride. And once you approach life with ease, you get to live out the beauty of your true self! It's all connected.

One of my favorite Human Design success stories comes from a man who was having a really rough time at his job. He worked for an international oil company and had just been demoted for not following through on a couple projects. After doing his Human Design chart, we discovered that he had the energy for starting new things but not finishing them. Project management was the worst role he could be assigned to! And yet that was his job.

Once my client gained an understanding of his true nature, he asked to be moved from management to project start-up. Very soon after, he found that working in a job that was in alignment with his true nature was pure joy. And to this day, three years later, he is doing the work he loves and getting paid very well for it!

My hope is that the information in your Human Design chart will set you free, and that this book will give you the information and the confidence to live

a life without limits and find your perfect place in the puzzle of humanity.

To begin, get your free chart at www.understandinghumandesign.com on the “Human Design Specialists” page. Once you have registered with the site, you will receive your chart within two to three days. Then get ready for the journey of your life!

Part One

The Basics of Human Design

Chapter 1

Navigating Your Chart

Many of my students ask me, “Does knowing your Human Design help you make more money, get healthier, and have better relationships?”

The answer is yes. Sort of. The promise in Human Design is different from other promises you've heard before. What I can promise is that we are not all created the same. Human Design shows us that there are five energy types: the Manifestor, the Manifesting Generator, the Generator, the Projector, and the Reflector. Each energy type has a different way of creating and making decisions. But that doesn't mean that we don't all have the same potential for wealth, health, good relationships, and happiness. It's just that we are each uniquely designed, and therefore our definitions of wealth, health, good relationships, and happiness will be different for each of us.

Setting the Stage

Some of us are designed for and truly desire massive financial wealth; others feel fabulously wealthy when we have the freedom to spend time with our loved ones. Some of us dearly want to find fulfilling work; others don't want to work at all. Some of us will be athletes; others will be intellectuals. Some of us are real go-getters by design; others will simply be at the right place at the right time, and magic will happen. All of these things are okay. They are simply variations on what it can mean to be “successful.”

While the traditional ways of creating success might work very well for some people, for some of us the rules simply don't work. But society and our conditioning have a powerful hold over us, and we can often feel that our personal definitions of success are lazy, weak, silly, or even ridiculous by society's standards. Continuing to follow this one path when it's not working will only bring frustration, bitterness, burnout, and exhaustion.

Think about it—if we're all different, a one-size-fits-all approach to creating a happy, successful life doesn't make sense. All people are equally valuable and important. But each of us has our own energetic blueprint and individual style of operating successfully in life. What might work for one person won't necessarily work for another.

The struggle to fit in and embrace society's definition of what is “right” and “successful” is really just about energy. The way we feel about ourselves, the rules and values of society, and the way we react to life are all dictated by our own energy field and the bigger collective energy field. The Human Design chart is your personal electrical schematic. It shows you what kinds of energies are consistent for you and which energies you take in from the world around you.

When you know who you are and how your personal energy field operates, you discover your inner authority that helps you navigate your way through the collective energy field. You may discover that you are in agreement with certain beliefs and energies that society holds dear, but in other areas you diverge from society's expectations.

The current trends in personal growth information claim that if you're not experiencing “wild success” by society's definition, then it may be a result of subconscious beliefs, trauma, or problems with your “success” mindset. I don't disagree; your beliefs, past experience, and attitude can influence your level of success. But often what is really blocking us from creating the life we love is a fundamental misunderstanding of what is truly right for us.

Instead of allowing the life that's right for us, we keep pounding away with different manifesting techniques and tools, trying to blast away those “limits” that might actually be keeping us from creating something that isn't desirable in the first place.

This idea of letting go and allowing our life to take us where it may can be scary at first. Most of us grow up without a strong realization of who we really are. Our energy fields are influenced by others around us, and we don't always know what is our personal truth versus what we've been told to believe is Truth. We often lose touch with our authentic self.

We worry that if we let our inner authority take control, maybe we are somehow doomed to be broke or lonely. We don't trust our inner guidance, and we wrestle with the prospect of being in control of ourselves. If we've led a life that is “less than successful,” we may even be instilled with ideas that we are somehow not worthy of abundance or that we are screw-ups. Don't worry. No one is doomed by design or energetically destined to suffer or screw up.

One of the greatest sources of pain in life is the disconnect between the self you perceive yourself to be and the authentic self. The greater the distance between the two, the more discordance and pain there is. This pain is not dysfunction or “brokenness”; it is simply the authentic self telling you that there is more for you here than you realize, and it might not look the way your head

thinks it should—it is actually much, much better.

The more you learn about yourself, the more freedom you'll have to create a life that is in alignment with what's right for you. So let's begin by taking a tour of your Human Design chart. If you haven't gotten your chart already, go to www.understandinghumandesign.com to get yours now.

Navigating Your Chart

Each Human Design chart has three parts: 1) the body graph, 2) the birth chart, and 3) the keynotes ([figure 1](#)). We'll cover each in detail, but first let's look at the chart as a whole. What do the shapes and layout remind you of?

If you look closely at the chart, you might see some visual evidence of the influencing wisdom behind Human Design. For example, the geometric shapes (called centers) look very similar to the seven chakras ([figure 2](#)).

Birth Chart

Body Graph

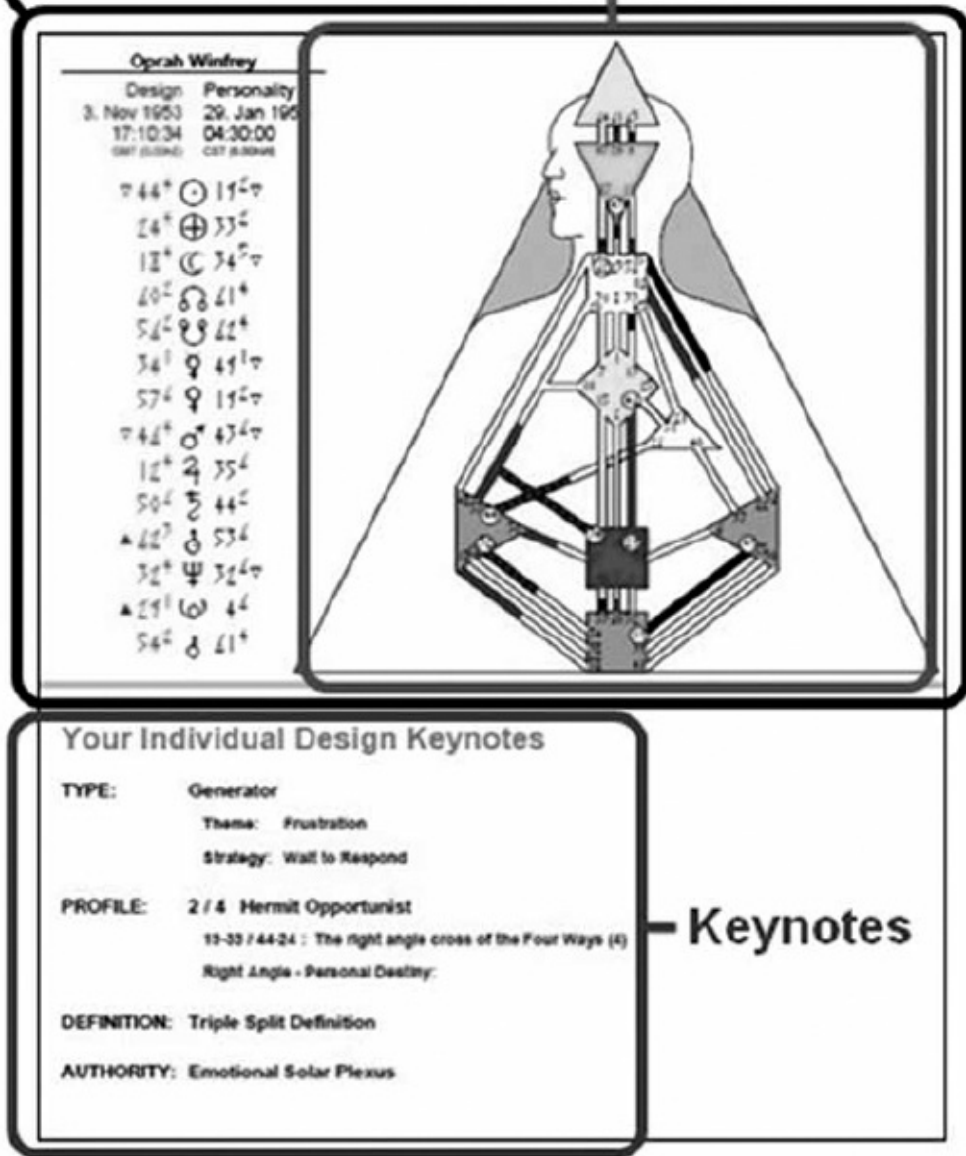

Figure 1: A sample Human Design body graph

If you turn the chart upside down, it looks very similar to the Tree of Life from the Kabbalah ([figure 3](#)).

Or you may notice that sixty-four numbers appear on the chart. These numbers, called gates, correlate to the sixty-four hexagrams from the I Ching. In the I Ching, a hexagram is composed of six stacked horizontal lines ([figure](#)

4), where each line is either yang (an unbroken or solid line) or yin (broken, an open line with a gap in the center).



Figure 2: The nine centers in Human Design are similar to the seven chakras.

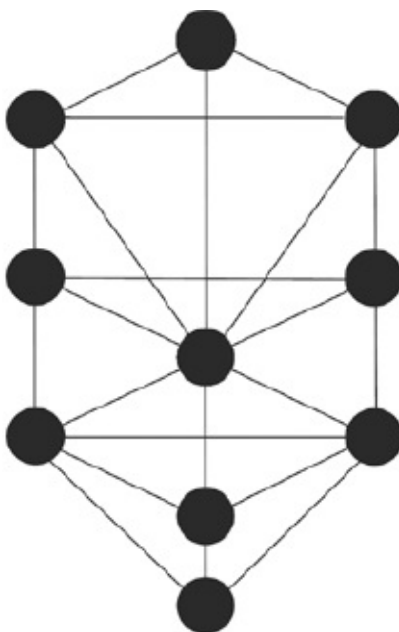

Figure 3: The approximate shape of the Human Design chart is similar to the Tree of Life from Kabbalah.

Though you can see pieces of these ancient wisdom teachings in the chart, Human Design is something new and unique, a brand-new tool to help people in a brand-new way.

It is important to realize that when you look at parts of the chart, they are simply pieces. To make learning about Human Design easier, we have to start first by taking the chart apart, piece by piece, and covering each one by one. But once you have a handle on how the chart is constructed, and how to read it, the “story,” or personal energy map, is revealed when you put all of the pieces together.

Synthesis is the key to understanding Human Design and each individual chart. At its root, Human Design is a tool that teaches us about the power and possibility of evolution in mankind on a personal, relationship, and collective level. The real beauty of Human Design is truly in the unification of all of its unique esoteric components.

Hexagram



Figure 4: The sixty-four gates in Human Design correspond to the hexagrams in the I Ching.

The actual chart is also a synthesis of several parts that work together to give an overview of each individual. Some of the individual pieces of the chart have energies that are similar but different on a subtle level. Please understand that as you learn about each part, we are, to a certain degree, taking pieces out of context. Each piece is important, but the full expression of each part will depend on what else is in your unique chart.

If you've ever tried to complete a jigsaw puzzle, you know that each individual piece is crucial to the full expression of the picture. Human Design shows us that the entirety of humanity is like one giant divine puzzle, and we are each a unique piece. When you are not expressing the full potential of who you are, you are, in essence, losing or mangling your personal piece of the puzzle. The greatest gift you can give the world is to be the fullest expression of yourself.

Let's now look at the three major parts of your Human Design chart—the body graph, the birth chart, and the keynotes—in a little more detail.

The Body Graph

When you receive your Human Design chart, you will see a series of numbers and planetary symbols next to a triangle comprised of all kinds of lines, geometric shapes, colors, and the profile of a person. This triangle, called the body graph, is the visual compilation of all the numbers and written information on your chart. The body graph is, in essence, a “map” of your unique energy configuration.

The Nine Centers

The first things you may notice when you look at your chart are the nine geometric shapes. These shapes represent the nine centers, and their role is similar to the seven chakras. Each center is responsible for carrying and managing a certain frequency of energy, and it relates to a specific theme in our lives ([figure 5](#)).

The nine centers and their themes are:

- Head: Inspiration
- Ajna: Certainty
- Throat: Communication and action
- Identity: Self, love, and life direction
- Will: Willpower and value
- Emotional Solar Plexus: Emotional clarity
- Root: Adrenaline energy
- Sacral: Workforce and life-force energy
- Spleen: Survival, intuition, immune system, and time

Next, you might notice that some of the centers in your chart are white, while others are colored in. The white centers are undefined, or open. The defined centers are colored in.

9 Centers

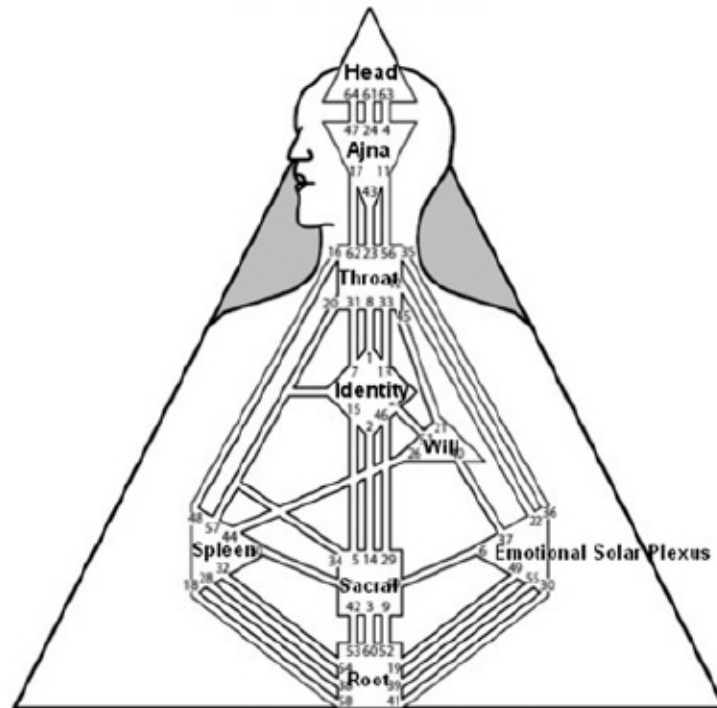

Figure 5: The nine energy centers are represented by the geometric shapes.

DEFINED CENTERS

If a center is colored in, it is “defined.” Defined centers represent the energy that you radiate out into the world consistently, the aspects of your personality that are true all of the time, independent of any other factors in your environment. It can be raining, Mercury can be in retrograde, Mars can disappear out of the solar system, but your definition (the colored-in parts of your chart) always stay the same. Your definition comes from the position of the gates and the planets at the moment of your birth.

As you will learn, defined centers have their own issues, but overall they are much easier to manage than the sometimes traumatic experiences of open centers. Some good general advice is to know and live your Human Design strategy (covered in [chapter 3](#)). It will empower you to always know what to do.

OPEN CENTERS

If a center is white, then it is undefined, or open. Open centers take in and

amplify energy and information from the world around you. The energy in open centers is inconsistent, because it changes depending on who you are with. It can also feel more intense than defined energy, because it comes in waves and is always changing.

It is easy to assume that the energy in your open centers is yours, and sometimes you will try to “fix” an aspect of your personality, not realizing that you are behaving according to outside factors. Notice where your open centers are; these are the places where you have the potential to have the most pain until you understand how your energy works. But these open centers also hold the potential for your greatest wisdom as well.

Before I was aware of Human Design and my undefined energies, I worked as a nurse, and I was exhausted all the time. I burned out very quickly, because the emotional intensity was overwhelming, and I would soak it up like a sponge. Now, using the tools of Human Design, I understand that I have an open Emotional Solar Plexus. And I am now equipped to allow all that emotional information to pass through me. I don't hold on to it and claim it as my own, and I don't burn out.

MOTOR CENTERS

There are four centers on the body graph which we consider to be the motors: the Sacral Center, the Will Center, the Root Center, and the Emotional Solar Plexus. Motors help define the kind of energy you have.

- Sacral Center: This is the energy for working, nurturing, and sexuality. It is sustainable energy. It can keep going without breaks or rest.
- Will Center: This is where your willpower is located in your chart. Willpower in Human Design is the energy for managing and creating physical resources and endurance for short periods of time. It is an energy that requires cycles of rest.
- Root Center: Adrenaline is located in the Root Center. This is energy that gives you an adrenaline push. It operates in on/off cycles.
- Emotional Solar Plexus: This is where your emotional energy is located. Emotional energy cycles through inward integration and outer expression, and your mood is often influenced. When the mood is right, this is the energy for creating.

PRESSURE CENTERS

There are two pressure centers: the Head Center and the Root Center. The

configuration of the pressure centers in a chart helps you understand what kind of pressure you might be experiencing in your life and gives you new ways to work with the pressure so you can reduce stress and make more relaxed choices.

- **Head Center:** This can be a source of mental pressure. When the Head Center is open or undefined, you may experience pressure to figure things out or always feel like you need to find the answers to your questions.
- **Root Center:** This is the center for adrenaline energy. When the Root Center is open or undefined, you may experience pressure to get things done in order to feel “free.” Sometimes this leads to making rash decisions in an attempt to avoid pressure or stress.

ENERGIES IN A GROUP

The beauty in the defined and undefined centers lies in the fact that, individually, we are all simply parts of a greater whole. We all become completely defined when we are all together. We each bring pieces that energetically unify us all and offer us the opportunity to express all of the human experience.

You sense this when you go to a restaurant or a coffee shop. The designs of the customers and the staff blend together to make one big aura. This is great to know if you don't have certain consistent energies in your chart, such as the energy for focus. When you are hooked into other people's auras, you may find that your energy for focus is amplified through being around others, and you can create new strategies to help you stay on task when you need a focus boost.

Channels

Notice how the nine centers are connected to one another through many lines ([figure 6](#)). These lines are called channels, and there are thirty-two of them. The channel's color tells you about an aspect of your personality:

- **Black** channels carry personality traits that you are consciously aware of.
- **Red** channels carry personality traits that you are not consciously aware of.
- **Checkered** channels represent those particular personality aspects that are in your conscious and unconscious definition.
- **White** channels represent open gates. You will always take in the energy of both gates from the world around you, and its expression through you will depend on your environment.

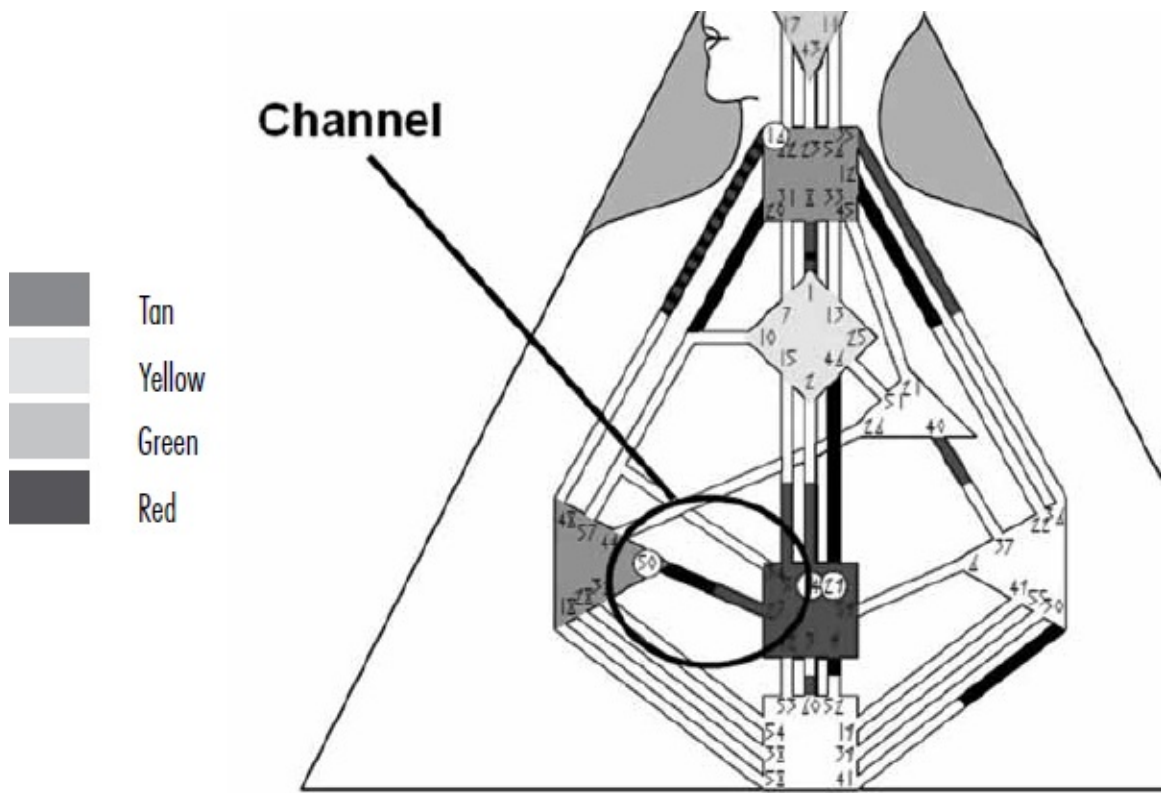

Figure 6: A channel connects two gates.

Gates

At the end of each channel is a numbered gate, and the channel is named using these two gate numbers. For example, we might talk about the 34/20 channel, the Channel of Charisma, which connects Gate 34, the gate of power, to Gate 20, the gate of metamorphosis. The sixty-four gates correlate to the sixty-four hexagrams in the I Ching. Each defined gate in your chart adds a different “flavor” to your personality. We will briefly discuss the nature of the gates here, but for an in-depth explanation of each gate and how it relates to your chart and personality, please see [chapter 6](#).

HANGING GATES

If you have a line that is colored in, then the centers on either end of the channel will be defined (colored in). An open (white) center has no fully colored channels attached to it. When only one of the two gates in a channel is defined,

it is called a “hanging gate” ([figure 7](#)).

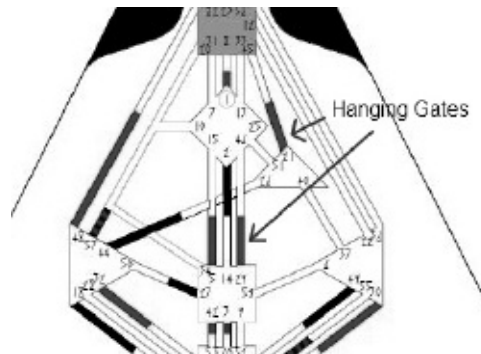

Figure 7: When only one gate in a channel is defined, the defined gate is called a hanging gate.

A person with a hanging gate is always attracted to people who have the other half of the channel. This is called electromagnetic attraction.

Definition

Definition of the chart refers to the colored-in channels between centers. Single definition means all of the centers that are colored in or defined in the chart are connected ([figure 8](#)).

Split definition means there are two distinct groups of energy centers that are connected within the group but are not connected to each other ([figure 9](#)).

Triple split definition means there are three distinct groupings of energy centers that are not connected to one another ([figure 10](#)).

Quadruple split definition means there are four distinct groupings of energy centers that are not connected to one another ([figure 11](#)).

An energy split can make you feel as if you have certain very distinct aspects to your perception of yourself. For example, in this chart ([figure 9](#)), you may feel you have a very powerful mind and can get “lost in your head” but that you also have an “earthy” and primal part of your personality as well.

We are often attracted to partners who have the gates that “bridge” our defined splits. When we are with that person, we feel “whole” or that all the parts of ourselves are unified, which is indeed what happens, at least energetically.

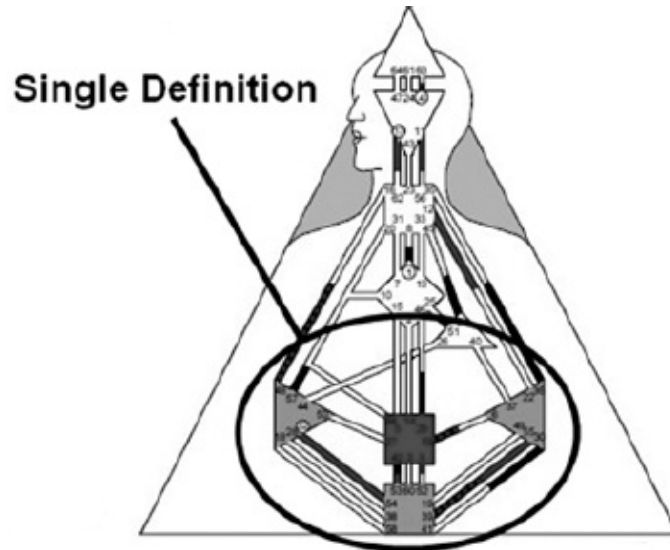

Figure 8: Single definition means all nine centers are defined.

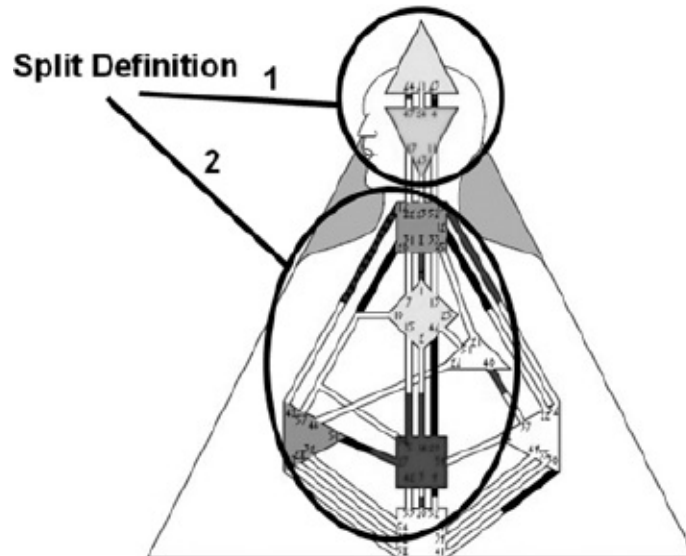

Figure 9: Split definition means there are two distinct groups of energy centers.

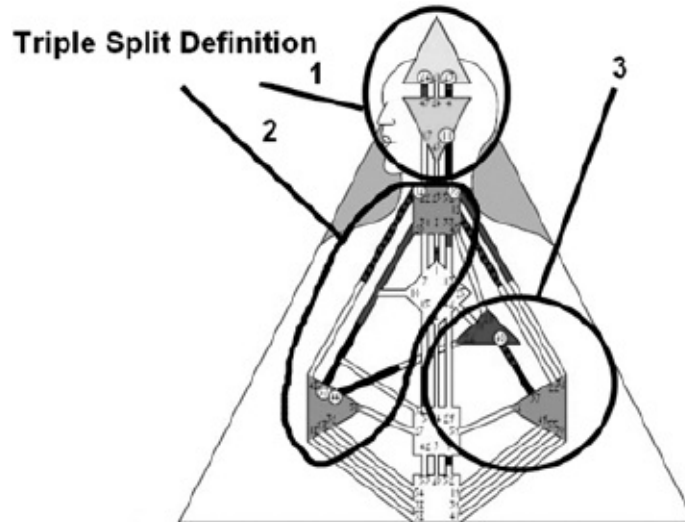

Figure 10: Triple split definition means there are three groups of centers.

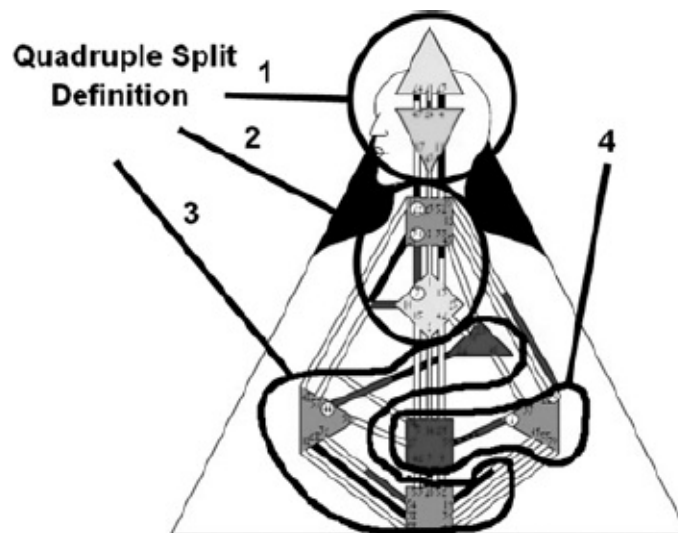

Figure 11: Quadruple split definition means there are four groupings of centers.

The Birth Chart

Let's move now from the human figure to the table with all the numbers and planetary symbols. On the left side of the chart or flanking either side of the body graph (depending on who provided your Human Design chart) you will see a series of red and black numbers and planetary symbols ([figure 12](#)). This is called your birth chart. Your birth chart is fixed; it does not change during the course of your life.

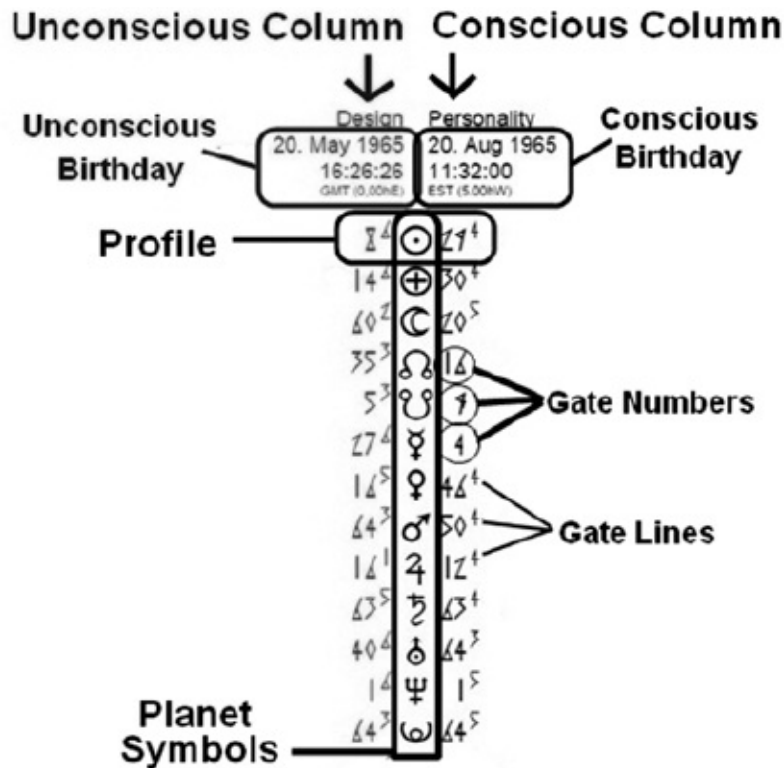

Figure 12: A sample birth chart

Your Unconscious Personality

Your unconscious personality is defined by the red elements on your birth chart —these are aspects of your personality that are consistent but unconscious, meaning you don't really have much control over these parts of your personality. Usually with age we become more aware of our unconscious personality. Your family and loved ones also usually know the unconscious elements of who you are.

The date in red is your unconscious birthday. The unconscious birthday is roughly three months prior to your birth and coincides with a large spurt in brain development in the cerebral cortex while a baby is in utero. It is approximately eighty-eight astrological degrees from the moment of your birth.

Your Conscious Personality

The elements on the chart that are black are aspects of your personality that you are consciously aware of and, to a certain degree, have some control over.

The birth date in black is your actual birthday, called your conscious birthday. (On some charts, the birthday may be in European format

[day/month/year]). This is your conscious personality.

Gate Numbers

The large numbers listed in either red or black are gate numbers ([figure 13](#)). There are sixty-four of these, and they are represented in the body graph. For more on what the gate numbers mean, see [chapter 6](#).

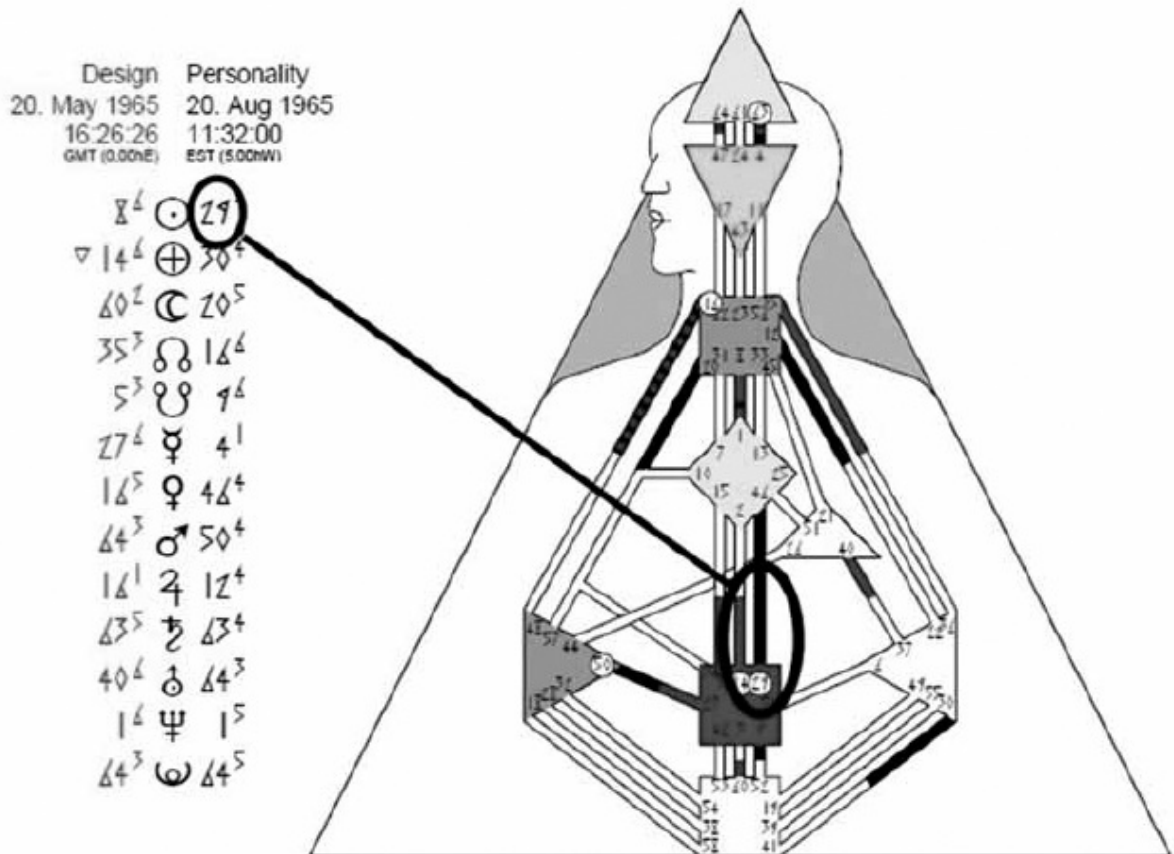

Figure 13: The gates appear in the birth chart and in the body graph.

Gate Lines

You will see that next to each gate number there is a smaller number that looks like an exponent ([figure 14](#)). This is a gate line. They are numbered one through six.

The gate lines are unique to each chart. Not every chart has all six lines. It depends on the position of the planets at the moment of birth. Lines are like seconds when we measure time. Here are the gate lines' six unique archetypes:

- Line 1: Investigator
- Line 2: Hermit
- Line 3: Martyr
- Line 4: Opportunist
- Line 5: Heretic
- Line 6: Role Model

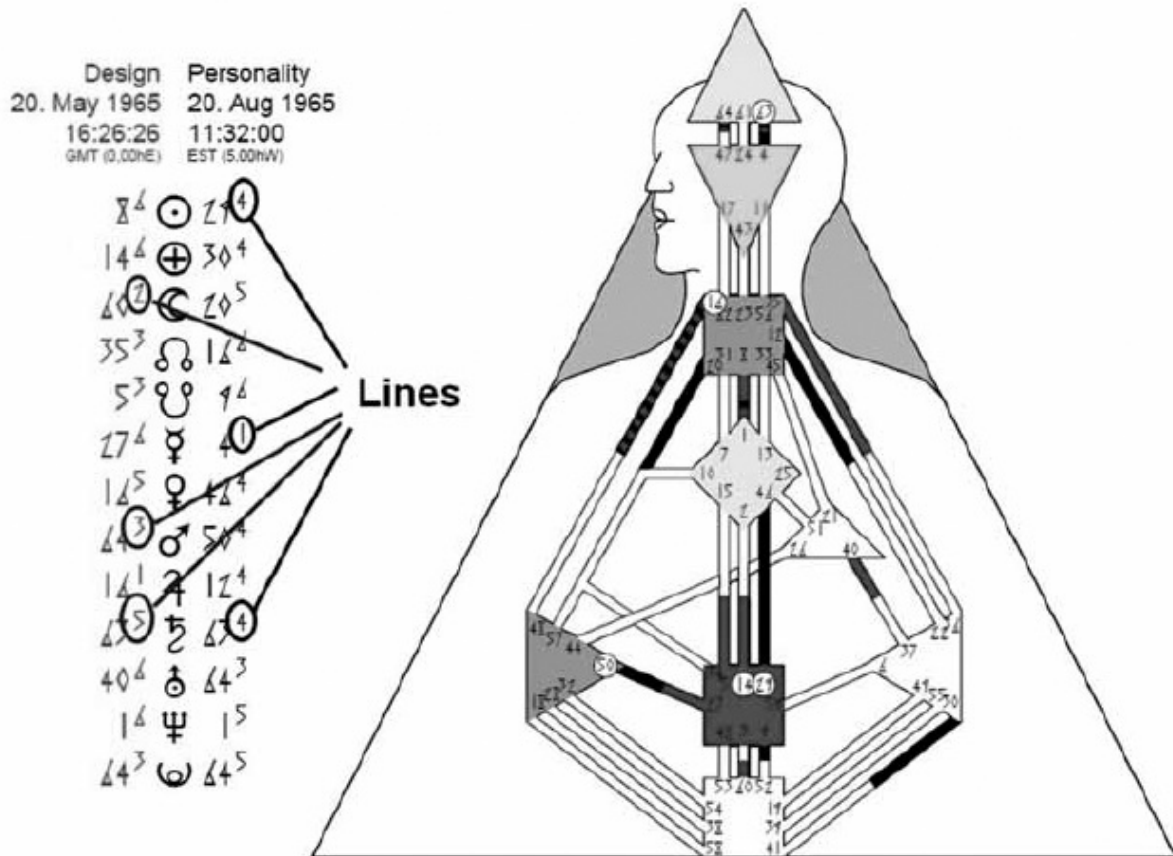

Figure 14: Gate lines

Note that the gate lines do not appear on the body graph. Their meanings can be revealed during a Human Design analysis.

Profiles

Your profile is determined by the gate lines in your conscious and unconscious Sun sign ([figure 15](#)).

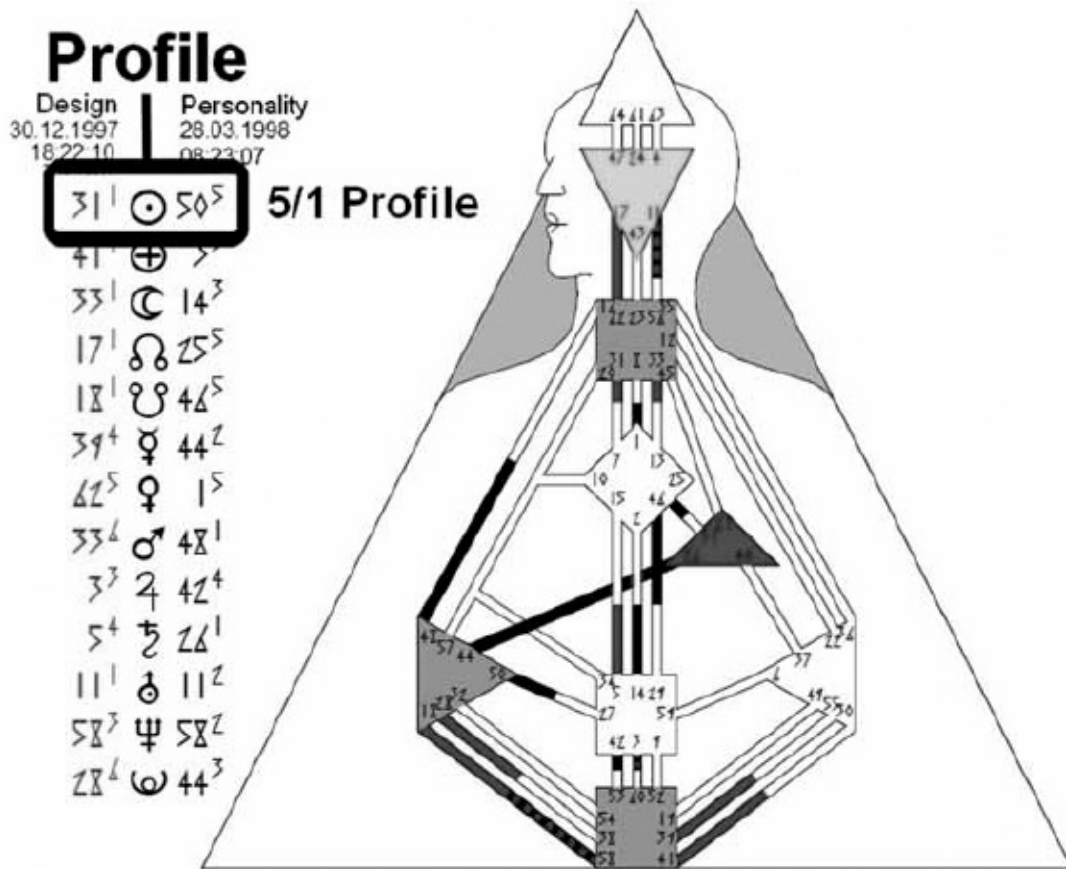

Figure 15: Your profile is determined by the top two large numbers in your birth chart.

Everyone comes into the world with a specific profile and purpose. Profiles tell you about major life themes that you will encounter, and they illustrate how your personality interacts with the world as you move toward fulfilling your purpose. Your profile can be thought of as an explanation of your conscious and unconscious archetype and the themes associated with those archetypes. Most people are aware of their unconscious profile, but because it is unconscious they do not have much control over the expression of it.

The twelve profiles are combinations of two gate lines (the conscious line followed by the unconscious line):

- 1/3 Investigator/Martyr
- 1/4 Investigator/Opportunist
- 2/4 Hermit/Opportunist
- 2/5 Hermit/Heretic
- 3/5 Martyr/Heretic
- 3/6 Martyr/Role Model

- 4/6 Opportunist/Role Model
- 4/1 Opportunist/Investigator
- 5/1 Heretic/Investigator
- 5/2 Heretic/Hermit
- 6/2 Role Model/Hermit
- 6/3 Role Model/Martyr

We will discuss profiles more in [chapter 5](#).

The Planetary Symbols

The planetary symbols indicate the astrological position of the energies in your chart at the moment of your birth. Each planet is covered, starting with the position of your sun gate at the top and ending with the position of your Pluto gate ([figure 16](#)).

Planetary Symbols

| | |
|---|-------------------|
| ☉ | Sun |
| ♁ | Earth |
| ☾ | Moon |
| ♊ | North Node |
| ♋ | South Node |
| ☿ | Mercury |
| ♀ | Venus |
| ♂ | Mars |
| ♃ | Jupiter |
| ♄ | Saturn |
| ♅ | Uranus |
| ♆ | Neptune |
| ♇ | Pluto |

Figure 16: The planetary symbols and their names

Incarnation Cross

The final piece of the chart that ties the whole thing together is called the Incarnation Cross. The Incarnation Cross is comprised of the energies that make

up your conscious and unconscious Sun and Earth signs—the top four black and red numbers in your birth chart ([figure 17](#)).

These four energies combined comprise about 70 percent of your personality expression. The Incarnation Cross is basically a person's life purpose. It tells us who they are, what they are driven to do, their foibles, follies, and ultimately their destiny, if they choose.

The meaning of each cross is a combination of the four gate energies that comprise it. The gate energy in the conscious sun position—the top right black number—is the most significant of the four. All of the other energies in your cross, and in your whole chart, are expressed through the conscious sun gate energy. Over the course of a year the sun will move through all sixty-four gates.

There are 192 possible Incarnation Cross combinations, each one a reflection of the solar and earth transits. The Incarnation Cross gives us much more information than a mere sun sign in astrology. It offers a deeper explanation for the path of a soul and the journey of a lifetime.

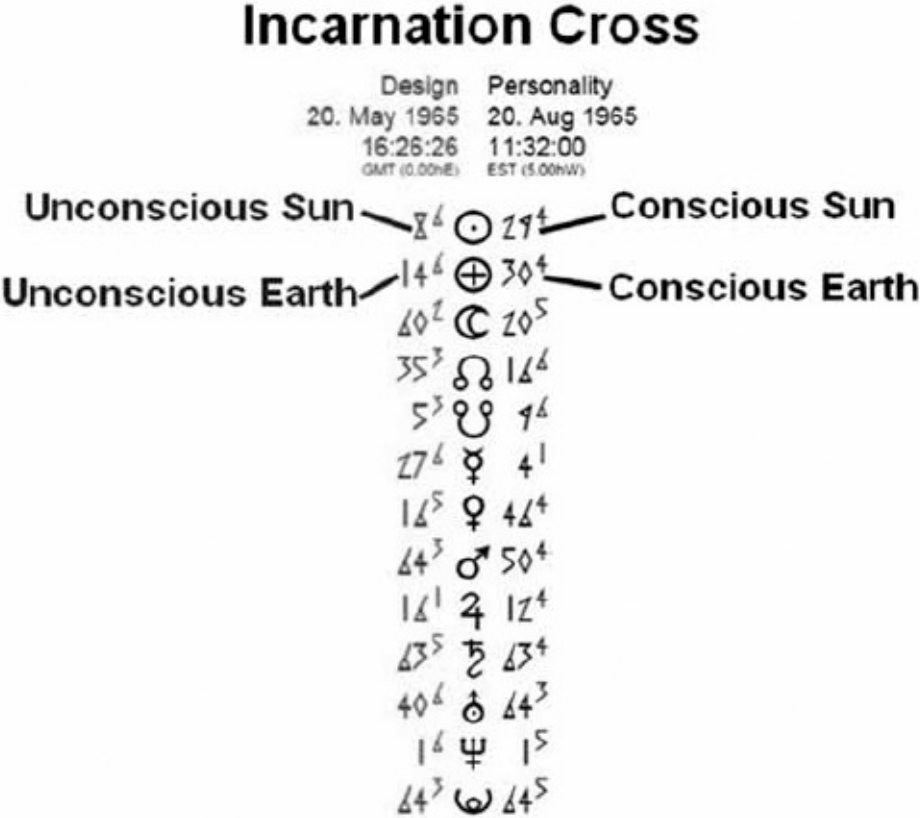

Figure 17: Your Incarnation Cross is comprised of both your sun and earth signs.

The name of your Incarnation Cross is usually found on the bottom half of

your Human Design chart. While we don't have the space to cover all 192 possible combinations here, you can read about each of the four gates that comprise your cross and weave your own story of your life path from those.

The Keynotes

At the bottom of your chart you will see a section called Keynotes, which is a short summary of the most important parts of your chart. The keynotes tell you

- your type and your unique decision-making strategy,
- your authority—whether you are spontaneous or whether you need time to make good choices—and
- your emotional theme—which emotion you may find most challenging in your life. (Rest assured, if you live true to who you really are, you dramatically improve your experience of your emotional theme.)

Your Type

The easiest way to begin benefiting from Human Design is to learn your type and to follow the strategy for your type. The five types are: the Manifestor, the Manifesting Generator, the Generator, the Projector, and the Reflector. You can find your type at the bottom of your Human Design chart in the Keynotes.

Each of the five personality types has a unique strategy for making decisions and being in the world. Knowing your type can help you develop confidence and trust in your capacity to make reliable decisions for yourself.

YOUR STRATEGY

Your strategy comes from your type, and it is probably the most important knowledge offered by your Human Design chart. It gives you key information about how to make the right choices for you, and how to recognize when you are on the right path.

Following your strategy offers you the opportunity to experience events and circumstances that are correct for you, while not following your strategy can bring events and experiences into your life that may not be beneficial in the long run. Follow your strategy and you will truly fulfill your personal destiny.

Because learning to follow strategy effectively can take months or years of practice, you can benefit from coaching by a Human Design analyst who can provide you with feedback and encouragement.

Authority

Although decision making is tied directly to your strategy, your authority flavors the way you use your strategy. Your defined centers will determine your authority. Not all centers carry authority, so your personal authority will depend on your type and your definition.

Authority will also depend on your life conditioning and your level of emotional well-being. When you receive a Human Design analysis, you are taught to understand patterns of pain and behaviors that may be keeping you from living out the beauty of the mythology of who you really are. With cognitive awareness of old patterns, you begin to heal and transform these energies into deep sources of wisdom. The more you clear your old energy patterns, the more effectively your natural decision-making skills (your authority) can function. You can then begin to use your authority along with your strategy to help you make better decisions for your life.

It's very important to note that authority does not override your strategy—it just shifts the way you use your strategy so that your decisions and choices are even more in alignment with the overall energy in your chart.

There are six kinds of authority:

- Generated
- Splenic
- Emotional
- Ego
- Self-Projected
- Mental

Some kinds of authority have a strong influence on the chart. Others are more subtle and don't require much, if any, change in how you live your strategy. We'll talk more about authority in [chapter 3](#).

Emotional Theme

Each Human Design type has an emotional theme. The emotional theme is simply part of a person's life, and it brings lessons and opportunities for growth. You will either be experiencing the emotions of your theme yourself, or you may be experiencing them through the other people around you who are responding to your behavior.

When you experience your emotional theme in a strong way, it's usually a

sign that you are not living true to yourself. For example, the emotional theme for Generators is frustration. Generators have to wait for things to show up in their outer reality and then respond to them as part of their decision-making strategy. If you are a Generator, and you are forcing things to happen in your life without waiting to see if they are right for you, you will most likely experience a lot of frustration, because things won't work out the way you had hoped.

It's always good to take a step back and evaluate your life if you're feeling your emotional theme in a powerful way. When you live your life according to your Human Design strategy, you lessen the intensity of your experience of your emotional theme. You might feel it here and there, but it won't be a roaring monster that dogs you day and night.

Summary

The parts of your Human Design chart—the body chart, the birth chart, and the keynotes—are each in and of themselves important and give insights into a personality. Understanding each part and the role it plays in the story of your life helps you put together a bigger picture and a deeper understanding of who you truly are.

Remember that each part is a piece of a whole. While we have to take the chart apart in order to understand all of its key pieces, the real beauty of the chart is in the synthesis of all its parts. The true story of who you are is revealed when all of the pieces come together.

The next sections of this book are designed to give you a practical guide to deepening your awareness of your true self and specific exercises and strategies to begin embracing what is right about you and your life.

Go through each of the pieces of the chart and do the exercises that relate to what is in your Human Design chart. This is a process that may take a bit of time. Many people like to pick one piece of the chart to work on for a week at a time. These exercises are intended to support you in connecting with your authentic self in a new and empowered way and to help you stay resilient during times of change.

Part Two

Types, Centers, and Profiles

As you can see from all the different parts of the chart, Human Design can seem quite complex. In spite of all its parts and pieces, the scientific process of awakening to your true self can be actualized very simply. Live your Human Design strategy according to your energy type, and you will discover who you truly are in an elegant and easy way.

In order to discover this truth, you first need to know which energy type you are. This is the subject of [chapter 2](#). Once you know your type, you simply follow your unique strategy.

In [chapter 3](#), we will look at how your type is determined—by the nine energy centers. Learning about the centers will give you deeper insights into how you operate, where you may have old energy patterns that may be keeping you stuck, and what you are here to become wise about.

We all learn in different ways. In [chapter 4](#), we'll look at the twelve profiles in Human Design. Each profile represents a unique learning style which influences how you experience the world.

To get a clearer picture of who you truly are, you have to start with understanding your type, centers, and profile. Just these three basic pieces of the Human Design puzzle will give you enormous insight into what you are here to share with the world.

Ready to get started?

Chapter 2

The Five Personality Types

If you're like most people, you've probably gone through your life doing “okay.” Maybe you've had some success. Some things in your life have worked out. You feel that more is possible, but you just don't quite know how to fully activate what you sense is inside you.

The truth is, most of us aren't raised to really live out the full power and potential of who we are. In fact, most of us are raised to do the opposite of what is right for us. We are taught to go out in the world and make things happen. While that works for some people, for most of us taking that kind of action just results in feeling frustrated, bitter, or disappointed that we didn't get what we tried so hard to create.

We are all powerful creators. But in order to create in a powerful way, you have to know how you operate. Your Human Design type shows you exactly how to create in a way that is empowering, fulfilling, dynamic, successful, and exciting.

Because your type is one of the easiest ways to learn from Human Design, and one of the most important, we'll start with this aspect of your chart first. As you can see in the table and chart below ([figure 18](#)), most of us are Generators of some kind. Many are Projectors, a few are Manifestors, and if you are a Reflector, you're very rare indeed.

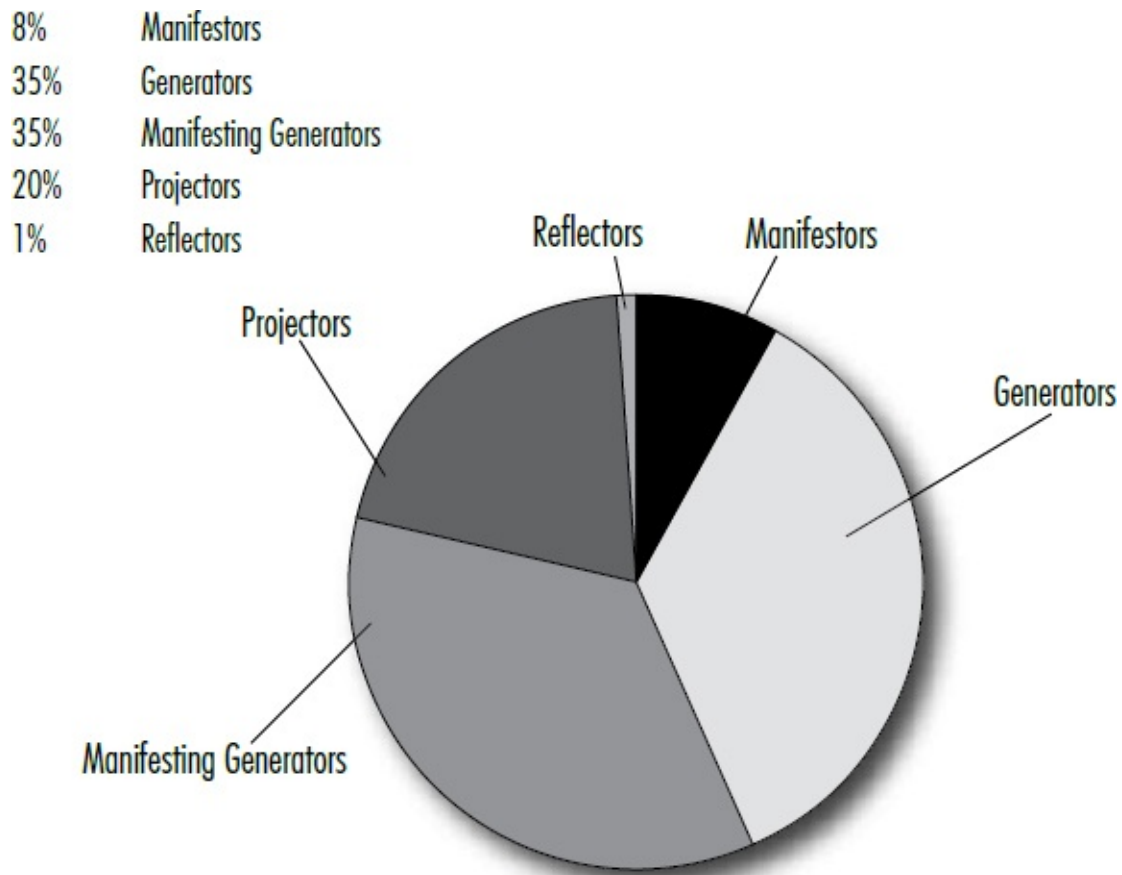

Figure 18: Seventy percent of the population is either a Generator or a Manifesting Generator.

The Manifestor

Manifestor audio download:

www.understandinghumandesign.com

The Manifestor

Strengths

- Energetic, driven
- Powerful, influential
- Successful
- Impulsive
- Mysterious

Weaknesses

- Angry, irritable
- Self-absorbed
- Not a team player
- Impatient
- Secretive

Energetic, powerful, effective, impulsive, and mysterious, Manifestors are one of the rarest types in the Human Design system, making up just 9 percent of the population.

The Manifestor's Chart

Besides having your type listed in the keynotes section of your chart, you can identify your type as a Manifestor because:

- You have a direct defined channel from the Throat Center to one or more of the motor centers.
- You have an open Sacral Center (see [figures 19–21](#)).

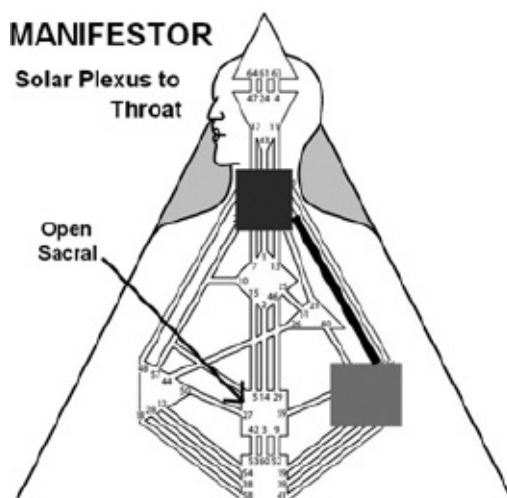

Figure 19: A Manifestor has a direct defined channel from the Throat Center to one or more of the motor centers—in this case the Solar Plexus.

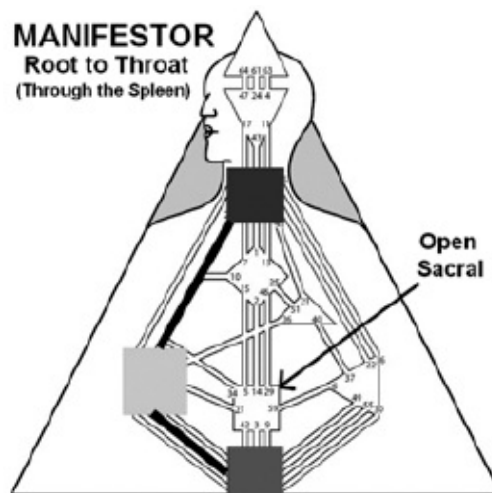

Figure 20: A Manifestor with a defined Throat to Root

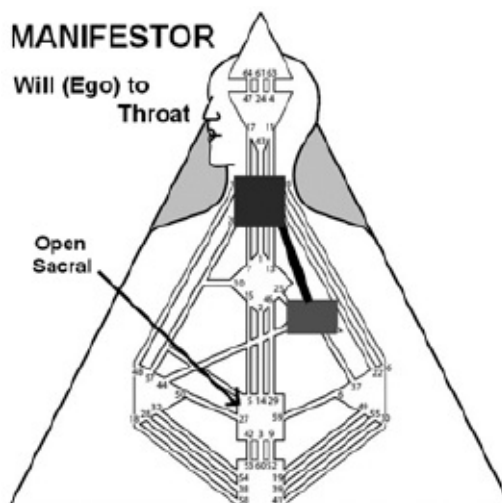

Figure 21: A Manifestor with a defined Throat to Ego

When a motor is directly connected to the Throat Center, it gives a person the energy to start things, such as conversations, or even businesses, without waiting. Manifestors have the energy to start things, unlike most of us, who

have to wait for an opportunity or invitation.

A Manifestor is constantly manifesting in their mind. When a Manifestor gets an idea, they just go do it. And they can usually do it quite well. A Manifestor is the only type that is pure energy.

Secretly we are all conditioned to believe that we are Manifestors. We are told as small children to “just do it” and to “go out and make things happen.” For most of us, this becomes a frustrating experience that never really bears the fruit we intend it to.

In spite of their tremendous initiating energy, a Manifestor is not able to work in a sustainable fashion. (This is represented by their open Sacral Center.) A regular Monday through Friday, nine-to-five job is exhausting for a Manifestor, and most Manifestors faced with those kinds of work options will feel overwhelmed or even angry.

Because Manifestors are the only type who can truly just do things without waiting, their energy can make people a little uneasy—especially if they don't understand their own energy. When a Manifestor speaks or enters the room, most people will feel their energy—they will have a powerful presence, and a powerful voice to match—but no one ever really knows what a Manifestor is about to do. This creates an aura of mystery and sometimes even nervousness.

Because Manifestors can initiate action, they don't necessarily need others to make things happen. A Manifestor gets into a kind of “manifesting groove” and simply creates in accordance with their powerful creative energy.

Manifestors can often have communication issues. Being so energetic and driven, a Manifestor in action can resemble a bullet train speeding to its final destination. But what Manifestors sometimes don't realize is that there are people waiting at stations along the way hoping to get on, but the train doesn't ever stop. The people waiting for the train either feel angry or left out; they're confused and frustrated. If they're going the same way, why can't the Manifestor slow down for a second so they can make their way together? Eventually they may give up and catch a different train.

The Manifestor, meanwhile, doesn't see what the problem is. Didn't she get to the destination with great efficiency and speed? Why are others trying to control her process? (She is doing very well on her own, thank you very much!) You can see how these two perspectives—one collaborative, the other individualistic and results-driven—might clash on some points.

The Manifestor's Strategy: Inform

The Manifestor's strategy is to inform others of her actions. A powerful Manifestor can soften the impact of her energy and harness it to serve herself and others by taking note of all the people who will be impacted by her actions and then tell them what to expect.

Informing does not come naturally for Manifestors, and they may feel controlled or manipulated by their impact field. Manifestors are not here to be told what to do. Most Manifestors do not tell others what they are doing because they learned very early on that others will try to stop them or tell them that what they want to do is not possible.

But Manifestors who understand that informing can improve their relationships and remove resistance, will create support for their power and creative energy. It is important for Manifestors to remember that just because they inform doesn't mean that they have to stop or change what they are doing. They are just letting people know what to expect.

And just as others will feel more loved when a Manifestor shares their plans, so too will Manifestors also feel more loved and respected when others inform them about what is happening. If you love a Manifestor, tell them about what you are doing. It helps them create and takes away some of their natural anger.

Special Traits: Power Struggles

In the short run, a Manifestor can amplify the energy of the Sacral Center and do more work than the average person. But because Manifestors do not have sustainable energy, others may feel frustrated with their apparent laziness once their initial energy burst peters out.

Remember, Manifestors are not here to work; they are here to initiate. Just because Manifestors can initiate activity, one must not assume that a Manifestor can work long hours doing physical labor or other types of the “daily grind.”

The Manifestor's Health

Manifestors need breaks and time to discharge excess energy out of their system. This can make them look like slackers and loners. But the need to retreat and rest is vital for maintaining the Manifestor's health.

It is not uncommon for Manifestors to struggle with insomnia or wakefulness at night. Because Manifestors do not have a defined Sacral Center, they are not designed to be “worn out” at the end of the day, and they need to lie down and relax before they can fall asleep. This means that Manifestors get healthy sleep when they go to bed before they are tired. If a non-Sacral person waits until

they are exhausted to go to sleep, then the quality of their sleep may be poor.

Manifestors will also tend to sleep better by themselves. Manifestor children tend to do better if they have their own room and sleeping space as well. The idea of sleeping alone can be difficult for Manifestors to understand, but this is not a personal issue. The time spent sleeping alone helps the Manifestor discharge the extra Sacral energy they have been amplifying throughout the day. Manifestors will sleep better, feel better, and be healthier in the end if they get a chance to renew their energy. And they will do it their own way. They are designed to.

Parenting the Manifestor Child

The Manifestor child poses an interesting challenge to parents. Truly, this is a child who is energetically designed to survive challenges and be naturally self-directed. Many Manifestor children grow up learning that they have to shut down their power, or they have to secretly just do what they want to do. Because of this, the idea of informing for a Manifestor is not only unnatural, it can seem frightening. The Manifestor is scared that people will try to tell them they can't do what they want to do or that they will be punished for being too powerful.

Most parents immediately sense that this is going to be a child who will need a lot of control. The parents do this not because they are willful or uncaring, but because the Manifestor child will do things that might seem dangerous or frightening to the parents. For example, a Manifestor child may look outside and see that it is a beautiful day. He looks down the street and notices the lovely forest at the end of the road. Because this is a child who is designed to follow his inspiration without any need for waiting, he goes out the back gate, down the street, and enjoys the forest for the afternoon (or maybe longer).

Truthfully, the Manifestor child is designed to be just fine staying in the forest for days if that is what he wants to do. But this can certainly be a frightening experience for a parent. A natural response would be to exert more control than usual over the child in order to keep him safe.

If you have identified your child as being a Manifestor, you must teach her to inform from the start. This process may take time, but it will serve your child for a lifetime. As a parent, it is normal to experience resistance if you tell Manifestors (or any children, for that matter) what to do. Instead, parents should empower these children to make choices so that they do not get deadlocked in a power struggle.

When parents approach the Manifestor child with an attitude of win/win conflict resolution, the child learns that her parents and others care about

helping her get her needs met. This allows the Manifestor child to be more open to informing and staying deeply connected to her inherent power.

Affirmations for the Manifestor

- I am a powerful being. I do not have to wait to exert my power.
- I make note of all the people who will be impacted by my actions and inform them about my actions. They do not have to like what I do or even agree to help me, and their resistance does not mean that I have to stop my actions.
- My actions give others things to respond to. By giving others things to respond to I am taking my place in the natural order of creation.
- I always attract the right people who will support my creative flow.

The Generator

Generator audio download:
www.understandinghumandesign.com

The Generator

Strengths

- Energetic
- Masters of their work
- Sustainable energy
- Self-aware

Weaknesses

- Often frustrated
- Quits too soon
- Can't just "make it happen"
- Can feel stuck

Besides having your type listed in the keynotes section of your chart, you can identify your type as a Generator because:

- You have a defined Sacral Center.
- You have no connection between a motor and the Throat (see [figures 22](#) and [23](#)).

The Generator's Chart

Generators have tremendous sustainable energy, and they are the only type designed to work. But they must find the right work and the right life force opportunities in order to feel happy. When Generators are doing the correct work, they turn on their Sacral motors and have a powerful source of energy available to them.

Generators will feel frustrated if they do not find the right work and the right expression of their life force energy. Frustration, however, is a natural part of the Generator process, and Generators must understand the energy of frustration in order to attract new things to respond to.

Basically, the Generator is designed to lead a happy, fulfilling life when they let life show up for them, as opposed to going out and making life happen. Generators, and all types who must wait, do well to set an intention and then wait for evidence in their outer reality that it is time to take action and that the direction is correct.

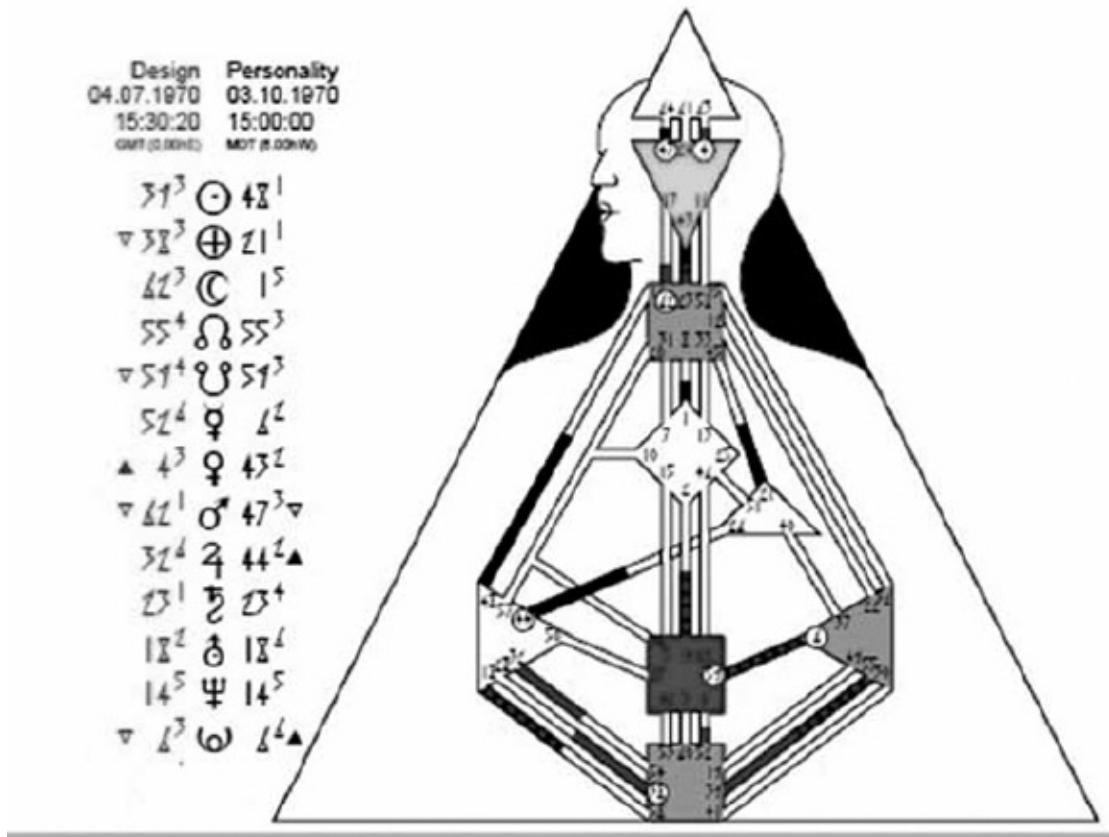

Your Individual Design Keynotes

DEFINITION: Split Definition

TYPE: Generator

Theme: Frustration

Strategy: Wait to Respond

AUTHORITY: Emotional Solar Plexus

PROFILE: P 1 / D 3

Right Angle - Personal Destiny:

Investigating Martyr

Figure 22: A Generator has a defined Sacral Center and no connection between a motor and the Throat.

The fear of the Generator, the “doer,” is that if they just sit and wait, nothing will happen. But the geometry of the Generator is that when they stop and wait, something shows up very quickly. Generators are always dancing with and

responding to life.

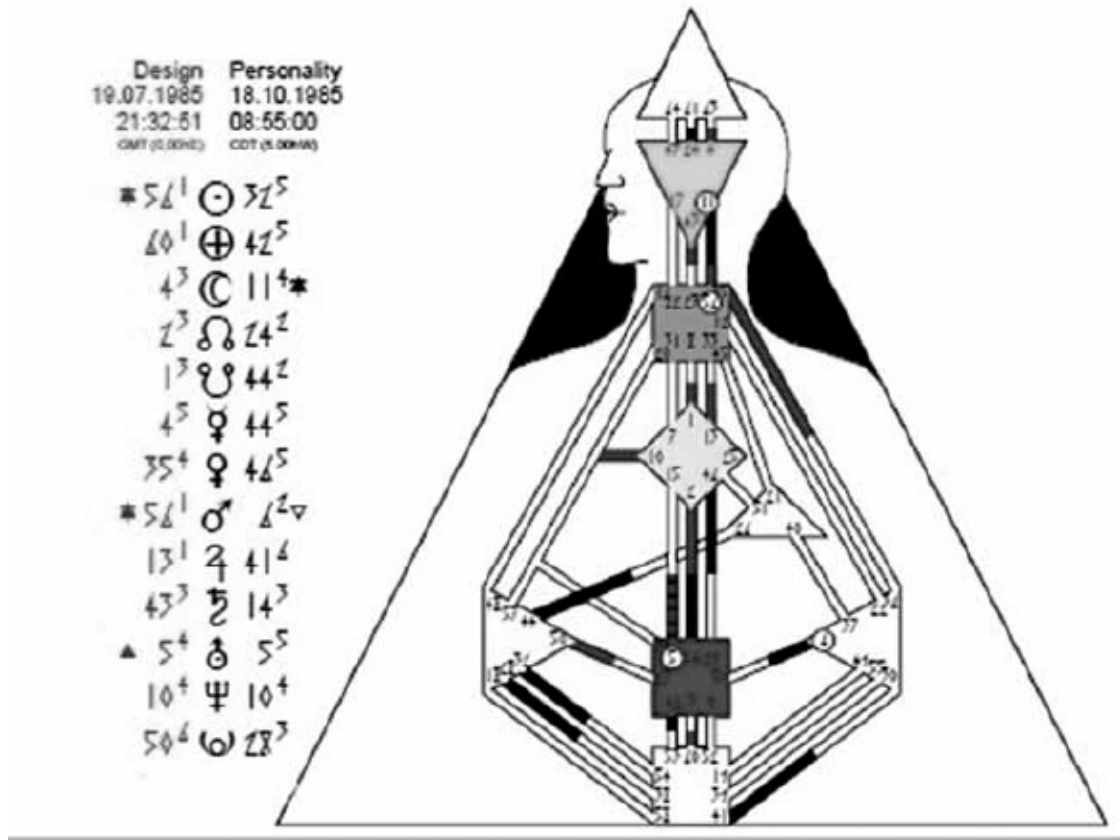

Your Individual Design Keynotes

DEFINITION: Split Definition

TYPE: Generator

Theme: Frustration

Strategy: Wait to Respond

AUTHORITY: Sacral Expressed Generated

PROFILE: P 5 / D 1

Left Angle - Trans-Personal Karma:

Heretical Investigator

Figure 23: A second example of a Generator chart

The Generator's Strategies: Wait to Respond and Know Thyself

There are two strategies Generators can use to address/equalize their weaknesses. They are: wait to respond and know thyself.

WAIT TO RESPOND

Because the Generator's primary motor is the Sacral Center, which does not have initiating energy, the Generator's strategy is to wait to respond. The Generator will feel pressured to initiate and follow through, but in reality their strength is on the follow-through only, not the initiation. Initiating is for Manifestors.

Most Generators find that life can feel very frustrating when they try to act as if they can initiate. The typical Generator gets an idea, fantasizes about what it will look like, and then goes into the world to bring the idea to fruition. This is how Generators are raised. They are told to “just do it” or “make it happen.”

Think about this: 70 percent of the population is raised to “just go out and do it,” and they are frustrated because it doesn't work. It is no mystery why so many of us are feeling stuck and trapped in jobs and lives that don't feel good. When a Generator tries to initiate action, he never gets what he wants, and he ends up spending a lot of energy working and pursuing things that only leave him feeling burned out and frustrated.

Because Generators have sustainable energy, they can basically become “enslaved” to their life if they are not responding. We live in a generated world. The Generators are the ones “doing” all the work (or at least they should be).

When Generators learn to respond instead of initiating, then they liberate themselves to do the work they love and free their energy in ways that most Generators can not even imagine. Waiting can feel most unnatural. But the Generator who waits and then responds to the right work will free themselves to do the work they love for a lifetime, or until something even better for them to respond to shows up.

KNOW THYSELF

The key to keeping a Generator's energy sustainable and breaking out of the conditioning field is to respond. The positive response of the Sacral turns it on and gives the Generator the fullest possible access to the Sacral energy.

Generators are the only type who can find clarity simply by responding to yes or no questions. If you are a Generator, ask someone you trust to sit down with you and ask you a series of yes or no questions about a situation you may be wrestling with. This will help you access your deep self-awareness in an easy and joyful way!

For example, imagine you are considering moving from your current home to a new one. The thought may seem overwhelming at first, but with a friend you can break down this big decision into a series of smaller decisions and gain clarity on what you really want.

- Do you want to live downtown? In the suburbs? In the country?
- Does your spouse or partner want to move?
- Will moving affect your children in a positive way? Will school districts affect which housing options you pursue?
- Would you buy a different house? Would you rent a condo or an apartment?
- Do you like having a yard and all the maintenance it requires?
- Are you ready to let your friends know that you are looking for a place to live?
- Do you want to work with a Realtor?
- If you do want to work with a Realtor, will you research potential Realtors in your area, or will you wait for an ad or encounter to bring the right Realtor to you?

Sleep on your responses and see which ones stay the same over time.

Special Traits: Frustration

The Generator has a stair-step learning curve, and frustration is a natural part of the process. Whenever a Generator learns something new, they have an initial surge in mastery. But over time, Generators will reach a plateau. Even if the Generator practices and practices, they will not make any improvement and they will feel frustrated. This is the point at which many Generators quit. The frustration of the plateau is intolerable. But this is a good sign. It just means that they are about to experience something new to respond to, whether that means a new level of mastery, a new job, or a new opportunity.

You see, Generators are designed to be masters. When the Generator has plateaued and feels frustrated, it means they are getting clear about what they want, and an opportunity to go to the next level will show up soon. At that point, all the Generator will have to do is respond.

The key for the Generator is to not quit when they feel frustrated. Listen to the Sacral. It is uniquely designed to place the Generator in the right place at the right time. Sometimes it will not respond to quitting, even when the Generator is feeling very frustrated. And sometimes it will respond to quitting, even when

the Generator is scared of losing their job or an opportunity.

Generators who are new to responding should experiment with their Sacral. Try not initiating for the next four weeks and see what happens. It may be something completely different from what you had imagined but much better than you'd thought!

The Generator's Health

The Sacral is designed to wear out at the end of the day. Most Generators try to get their second wind and miss the signs that their Sacral needs to rest and regenerate. If you are a Generator and you have a hard time falling asleep or sleeping well, it may be that you need more physical exercise to “wear out” your Sacral.

The Sacral Response

The energy of the Sacral motor gets turned on by sound. The sound of the Sacral is a frequency of energy. Once a Generator is turned on and starts responding with their sounds via sympathetic vibration, the other Generators in the room will also start making Sacral sounds.

The sounds of the Sacral are two sounds that most Generators learn are rude and unacceptable at an early age. The Sacral sounds are, “uh-huh” and “uh-uh.” Most Generators are unconsciously making those sounds anyway.

The Generator is designed to respond to questions and things that appear in the world with those sounds. And when they do, they wake up a frequency of energy within themselves that gives them self-awareness and the ability to know what to do and who to do it with. They have access to their inner truth and their inner direction. The Sacral response will always take them to the right place, doing the right work with the right people.

Because most Generators are taught not to make the sounds that are natural for them, when Generators first meet their Human Design they have to “wake up” their Sacral response in order to reactivate their Sacral motor. The best way to do this is to have other people ask you yes and no questions that you respond to with your Sacral sounds.

Imagine you are visiting an acquaintance you haven't seen in a while and he asks you if you want to come to work at his new company. If you say “uh-huh” (yes), the job offer might be a good work opportunity for you. If you respond “uh-uh” (no), the offer might not be a good opportunity for you. As simple as this example sounds, you will experience such situations if you are a Sacral

being.

If only it were so simple all the time! Alas, we don't always get a perfectly worded question that allows us to answer “uh-huh” or “uh-uh” out loud. Sometimes we get more subtle promptings, and that's when many Generators wonder if they are responding or initiating. Here are a couple examples of subtle Sacral promptings a Generator (or a Manifesting Generator) may experience.

Sometimes a Generator may respond to an internal prompting and won't necessarily have an explicit question or other auditory stimulus to respond to. Imagine, for example, that your sister has had a new baby and her husband calls to tell you about the new arrival. A typical response to this kind of news would be to go visit your sister and see the baby.

Assuming you have a good relationship with your sister, that feeling that you want to go see the baby might be considered an internal “uh-huh.” You are responding internally to the question, “Do you want to see the new baby?” You wouldn't wait by the phone hoping that your sister would call you to ask if you would like to see the baby. In fact, if you waited for a formal invitation to be extended before you visited, your sister might feel hurt.

Here is another example. Recently I was at a New Age expo in San Francisco. As I walked past a booth filled with green books, my body literally stopped and walked backwards to get a closer look, and I found a book that was just what I needed to help me in a phase of my business development. After perusing the cover, I got a big internal “uh-huh” to buying the book. I didn't stand at the booth waiting for someone to come up and explain the book to me and then ask, “Do you want to buy this book?” I just felt an internal tugging.

This tugging feeling from the Sacral Center typically results in something wonderful. Don't ignore it and wait for a verbal cue. You might miss some very correct opportunities.

WAITING FOR SOMETHING SOLID

If you have just started working with Human Design, I'd suggest that you wait for a question or opportunity to clearly form before responding. As you get more experienced with responding, you will begin to understand what a true response is versus an idea from your mind.

I wish I could say it will always be easy to tell if you are responding or initiating, but it may feel like a subtle distinction at times. I have learned through trial and error. For example, I am a Generator, and I've learned that if I come up with an idea about a workshop and just go ahead and teach it, odds are

no one will show up. I can do everything right—send out press releases, distribute flyers, personally invite guests—and yet the workshop just won't work out the way I envision it. *But*, if someone comes to me and asks me to teach the exact same workshop and I respond “uh-huh,” I experience a somewhat different outcome. The workshop fills with people, and all goes well. Being asked gives me something to respond to, and by responding “uh-huh,” I know it is correct for me to teach the workshop.

Be very careful, especially in the beginning, that something comes to you in a very clear way for you to respond to before you take action! As you practice living your design, you will gradually become better able to distinguish between responding and initiating.

TRUSTING YOUR GUT

So, what is the nature of responding? Well, theoretically, responding means answering a yes or no question with an “uh-huh” or “uh-uh” type of answer. In real terms, however, I believe it means trusting your gut, whether or not you have a specific question to respond to at a particular moment.

Most Generators become fearful that if they don't initiate, they will not receive opportunities to respond, and therefore will never accomplish anything in their lives. Life is simply geometry. All you have to do as a Generator is allow the geometry of your destiny to come to you. Wait, and you will get something to respond to!

A great master teacher gave me this analogy to illustrate the nature of waiting and trusting: Once upon a time there was a woman who wanted to cross a stream that was too wide, too deep, and too rapid for her to safely wade across. As the woman stood on the bank, she could look across and see the exact point where she thought she wanted to go. She paced back and forth along the stream, frustrated and confused about how to get to the other side.

As she stood alone at the edge of the stream, a gentle voice spoke to her and told her to look at the water. Before her very eyes, a beautiful, large, smooth river rock appeared in the water just the right distance away for her to step on safely from the bank of the creek.

The woman immediately stepped onto the rock, and, as she balanced, waiting, she began to feel frustrated again. She was now closer to where she wanted to go, but she still could not get there. In her frustration, she began to jump up and down on her rock.

Again, a gentle voice reminded her to look down at the water. As she looked down, a second beautiful, stable rock appeared just a little ways from the rock

she was standing on. The woman hopped gracefully to the next rock, this time a little bemused by the whole process.

This process repeated itself with a third rock, and then a fourth, and each time as the woman stepped onto a new rock she began to trust that another one would appear soon. She just had to wait. Slowly, she made her way across the stream and arrived at the other bank. By the time she got to the other side, she knew that wherever her life took her, opportunities to go further would always present themselves.

As a Generator, your life is like the stream. Stand on the edge, see where you want to go, and wait for the stepping stones to show up. When an opportunity to further your crossing appears, respond with your Sacral and see whether this is really an opportunity you want to commit to.

You may find that your path leads further up-or downstream than you originally intended. You may find that once you get out in the middle of the stream that the side you started out on was better than where you are headed. You may find that life will bring you the perfect rocks to lead you to the path of your greatest heart's desires. Follow the rocks and trust that they will always appear when you are ready!

Parenting the Generator Child

Generator children will benefit greatly from having the chance to express their Sacral energy through sound. Teaching them to respond to yes and no questions will save them a tremendous amount of energy in the future.

Generators, like all types, are not here to be told what to do. Instead, they are to respond to doing. But, in the collective experience, this is not always permitted. Think about the Generator child who does not respond to taking a math test. Perhaps they aren't ready. Perhaps they are not in the mood that day. Not responding affirmatively is, obviously, not an option.

Generators learn very quickly to do as they are told, even if they don't respond. Later, as adults, they are then told to go make things happen.

Generator children who do not get enough exercise may have a hard time falling asleep. When they get behind in sleep, then they may experience long-term chronic sleep deprivation. The symptoms of chronic long-term sleep deprivation mimic the symptoms of attention deficit disorder. Generator children who get to wear out their Sacral Centers every day are healthier and do better in school.

Affirmations for the Generator

- I trust in the infinite abundance of the Universe, and I wait for what is right for me to show up.
- I am perfectly designed to do the work that is right for me. When I am doing the right work, I am enlivened and energized.
- I always know what to do. I trust my Sacral response and go with my gut.
- I have to use my energy every day. I am an energy being with sustainable energy.

The Manifesting Generator

Manifesting Generator audio download:
www.understandinghumandesign.com

The Manifesting Generator

Strengths

- Energetic
- Can do many things at once
- Good at finding shortcuts
- Self-aware
- Sustainable energy

Weaknesses

- Emotional themes: anger and frustration
- Skips important steps
- Tries to “make things happen”
- Hates waiting
- Don’t always finish what they start

Besides having your type listed in the keynotes section of your chart, you can identify your type as a Manifesting Generator because:

- You have a defined Sacral Center (like a Generator).
- You have a direct connection between a motor and the Throat (like a Manifestor).

See [figures 24–26](#) for examples of Manifesting Generator charts.

As you can probably guess, the Manifesting Generator has aspects of their personality that match both the Manifestor and the Generator. Roughly 35 percent of the population are Manifesting Generators.

Manifesting Generators are designed to do multiple things at once. Usually, though, this is a great cover-up to disguise the fact that they have initiated several projects, and they are working very hard to make them work out, in spite of not having responded.

To others, the Manifesting Generator appears to be “all over the place.” But a Manifesting Generator is uniquely capable of getting more done than most people, and they can sustain this pace over a long period of time.

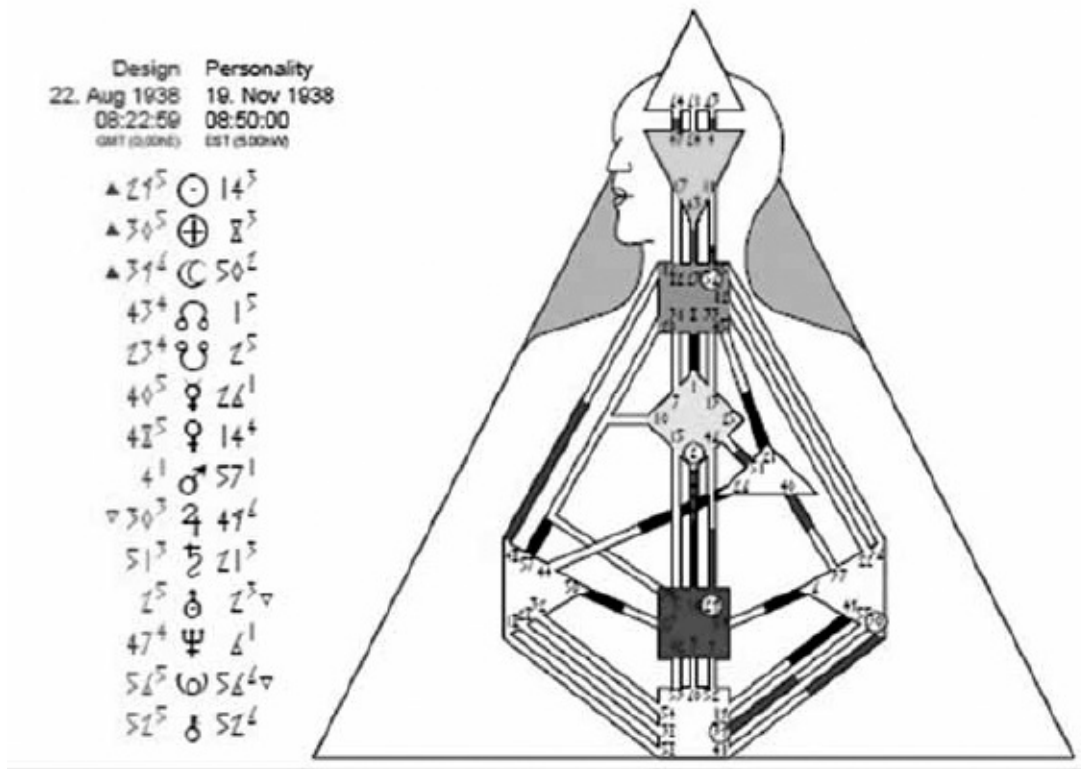

Your Individual Design Keynotes

- TYPE:** Manifesting Generator
 Theme: Frustration
 Strategy: Respond, envision, reprocess, Inform, act
- PROFILE:** 3 / 5 Martyr Heretic
 14-8 / 29-30 : The right angle cross of Contagion (4)
 Right Angle - Personal Destiny:
- DEFINITION:** Single Definition
- AUTHORITY:** Sacral Expressed Generated

Figure 24: A Manifesting Generator has a defined Sacral Center and a direct connection between a motor and the Throat Center.

The Manifesting Generator's Strategies: Visualize and Inform

VISUALIZE

Manifesting Generators should try on ideas in their imagination first and visualize the outcome. Then, they must wait before taking action.

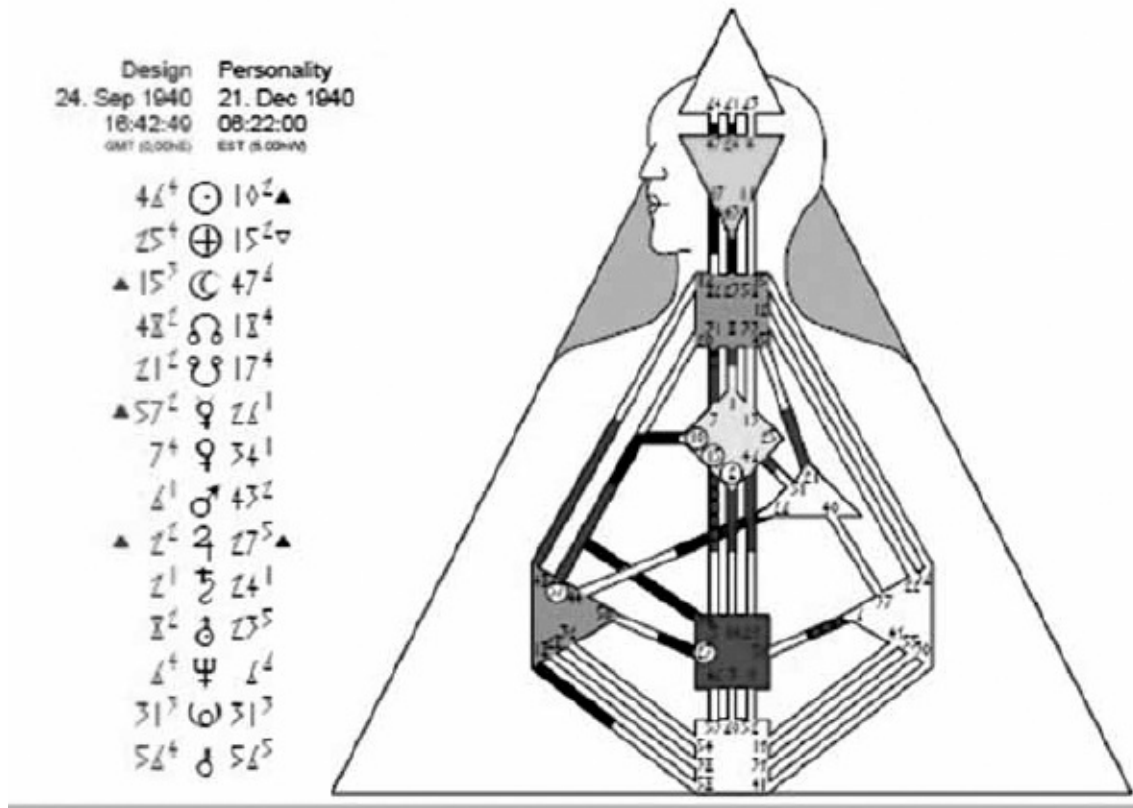

Your Individual Design Keynotes

TYPE: Manifesting Generator

Theme: Frustration

Strategy: Respond, envision, reprocess, inform, act

PROFILE: 2 / 4 Hermit Opportunist

10-15 / 46-25 : The right angle cross of the Vessel of Love (4)

Right Angle - Personal Destiny:

DEFINITION: Single Definition

AUTHORITY: Splenic Awareness Generated

Figure 25: Another example of a Manifesting Generator chart

Because of their configuration, and society's bias toward manifesting, Manifesting Generators often believe they are Manifestors. That is why the emotional theme of the Manifesting Generator is anger (from the Manifesting part of the personality) and frustration (from the Generator part of the personality).

INFORM

Manifesting Generators must also inform like Manifestors in order to stabilize the energy around them. They can go so fast that informing feels as if it is slowing them down, but informing will decrease the resistance that they feel from others.

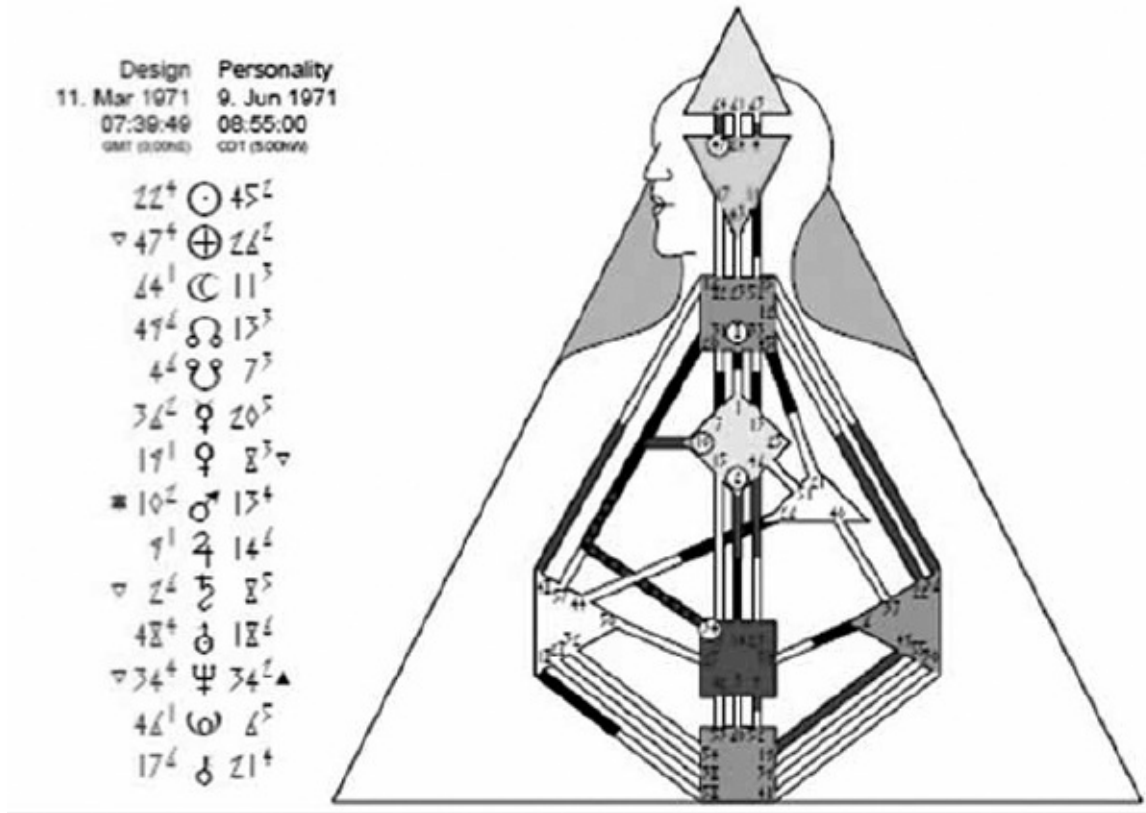

Your Individual Design Keynotes

TYPE: Manifesting Generator
 Theme: Frustration
 Strategy: Respond, envision, reprocess, inform, act

PROFILE: 2 / 4 Hermit Opportunist
 45-26 / 22-47 : The right angle cross of Rulership (2)
 Right Angle - Personal Destiny:

DEFINITION: Triple Split Definition

AUTHORITY: Emotional Solar Plexus

Figure 26: A third example of a Manifesting Generator chart

The Manifesting Generator who is not responding runs the risk of being very busy doing nothing. And because the Manifesting Generator is so fast when they do respond, they have a tendency to skip important steps and frequently have to go back and fix the steps they skipped.

If a Manifesting Generator and a Generator start the same job at the same time, the Manifesting Generator will appear to learn the ropes more quickly. But if you compare the two six months later, the Generator will have caught up, and they will both be at the same level of mastery, because the Generator has a more deliberate process.

Special Traits: Active Multitasking

What people often don't understand about the Manifesting Generator is that they *need* to do more than one thing at a time. If they don't get to express that part of their energy, it's actually unhealthy for them, and they can end up feeling very frustrated and angry.

Most Manifesting Generators feel that the world just doesn't move fast enough for them. If you're a Manifesting Generator, it's good to remember that most people are not able to do as much or move as fast as you. Try to be patient.

The Manifesting Generator's Health

Manifesting Generators have two important considerations when it comes to health: responding and making sure they are doing enough. The thyroid of a Manifesting Generator is exceptionally vulnerable. To stay healthy, a Manifesting Generator has to respond, which isn't easy for them.

A Manifesting Generator who is not doing a lot, and feels stuck or trapped, can also have thyroid challenges. When a Manifesting Generator is fallow, it's like trying to keep a lightning bolt in a glass jar. That energy has to go somewhere, and if it's not being used, it will ricochet around in the body.

Manifesting Generators, like Generators, need to wear themselves out each day to get good sleep and renewal. They need to stay active to stay strong and healthy.

Parenting a Manifesting Generator Child

Manifesting Generator children are always on the go! They need lots of activity, physical engagement, and the freedom to start things, experiment with them, and then quit if it doesn't feel right. Many parents worry that Manifesting Generator children won't stick with things. They will. But they have to try on a lot of things as part of their creative processes.

Many parents are challenged by the Manifesting Generator's seeming lack of attention to detail. It's not that they don't pay attention to details. It's just that they often miss things or skip steps while they create. It's important when you parent a Manifesting Generator that you help them correct what they may have missed without judgment or criticism. They are just being what they are—speedy creators.

The Manifesting Generator child needs to do many things to stay healthy and engaged. This can often be exhausting for parents, especially if they don't have this same kind of energy. Sometimes parents need help facilitating things for the Manifesting Generator child.

Anger and frustration can be a difficult challenge for the parents of the Manifesting Generator. Manifesting Generators have big, creative ideas, just like a Manifestor, but the need to wait, like a Generator. When things don't work out as expected, or if they aren't moving fast enough, the energetic meltdown can be difficult to witness and manage.

Sometimes a young Manifesting Generator can't articulate what is frustrating them. They move quickly, and the creative process isn't always verbal. When they are deep into the frustration/anger reaction, sometimes these guys will bite or throw things. Parents need to help their children learn to manage their energetic intensity appropriately. Helping the child burn off steam physically is often useful.

Everything that applies to parenting a Generator and Manifestor apply here to. If you have a Manifesting Generator child, also read the sections on parenting a Manifestor and parenting a Generator.

Affirmations

- Even though I am inspired and excited, I wait for something to respond and then take action.
- I am patient with others. Not everyone can move as quickly as I can.
- I need to do many things at once. It's who I am.
- It's okay to skip steps. If I need to go back and do something I missed, it's just a part of my intense creative process.

- I am a powerful creator. I inspire others to support my creative process when I respond and then inform people about what I'm doing.

The Projector

Projector audio download:

www.understandinghumandesign.com

The Projector

Strengths

- Managing and directing others
- Insightful
- Intuitive
- Magnetic and attractive
- Helps focus energy to accomplish great things

Weaknesses

- Perceived by others as lazy
- Can burn out
- Highly sensitive
- Lacks self-awareness
- Can be bitter

Besides having your type listed in the keynotes section of your chart, you can identify your type as a Projector because:

- You have an undefined (open) Sacral Center.
- You have no defined line from the motors to the Throat ([figure 27](#)).

Roughly 20 percent of the population are Projectors. The gift of the Projector is to manage, guide, and direct others. The aura of the Projector says, “Ask me a question. I know the answer, and I would love to share it with you.”

A healthy Projector has no bitterness or desperation. They simply wait. And when they are invited, the Generators and Manifestors are beautifully guided and set free to make the best use of their energy and creative expression. The world flows in a perfect order and every one of God's creatures assumes their divine role and it feels good to everyone.

Most Projectors are conditioned to believe they are Manifesting Generators,

and they can really struggle to keep up. They believe that they can initiate and do more than they are really capable of. And they can, for short periods of time. Because the Projector has an undefined Sacral, they can take in Sacral energy, amplify it, and do more than everyone else. But the energy of the open Sacral is not sustainable, and the Projector who is acting like a Generator runs the potential of hurting their bodies and their spirits.

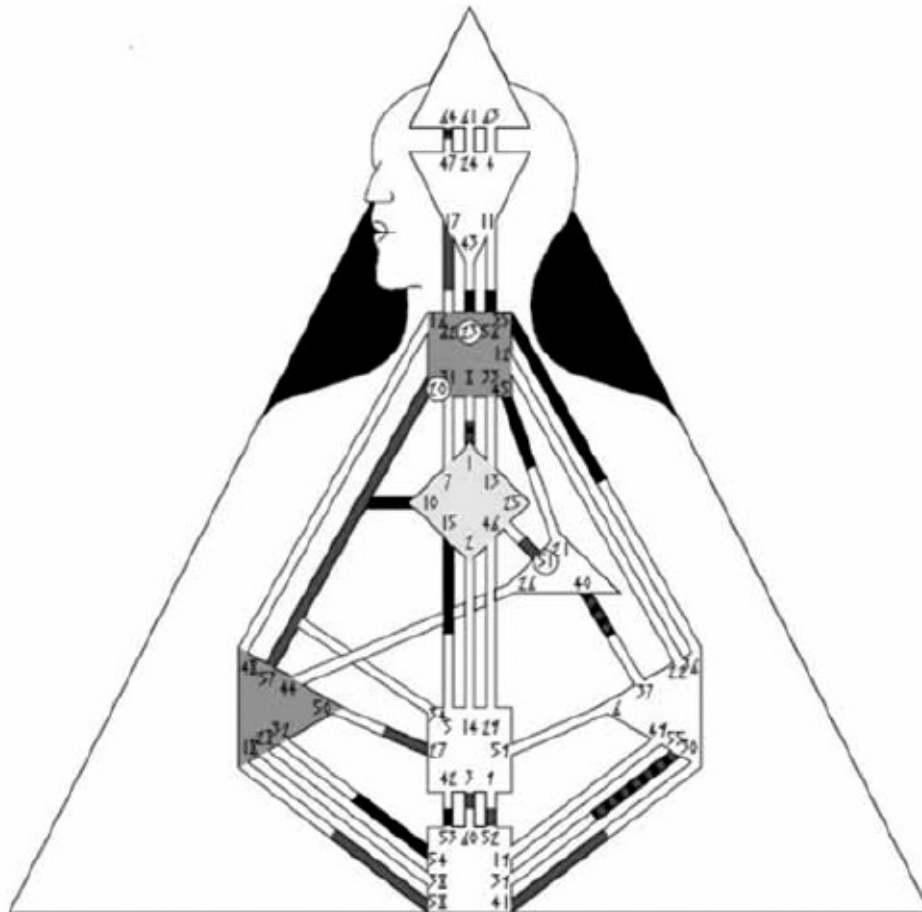

Figure 27: A Projector has an open Sacral Center and no defined lines between the Throat and the motor centers.

It is important for Projectors to understand that they are not here to work—at least not in the traditional way that we think of work. Working a regular, nine-to-five kind of a job is not correct for Projectors, especially if the work is physical labor. Projectors are not lazy. They simply don't have the same energy

for work as Generators.

The Projector's Strategy: Wait to Be Invited

Projectors can have the hardest time in life when they don't understand their type and their strategy. The Projector's strategy is to wait to be invited. The waiting of the Projector is about big invitations, such as love, career, and living conditions.

Unlike the Generator, who is constantly responding to life, the Projector gets big opportunities with very little in between. This can sometimes seem to Projectors and those who do not understand them that the Projector is “lazy” or just sitting around waiting for something to happen. But, that is really all a Projector is designed to do. Projectors who do not wait will not experience success. They do not have the energetic configuration to just go do things and “make things happen,” as many will tell them.

Because a Projector has no motor to the Throat and an open Sacral Center, they will struggle to be heard and recognized. Projectors can stand in a crowd and talk up a storm, but if no one has asked them to talk, they run the risk of not being heard, having their ideas stolen, or inadvertently insulting or criticizing the people around them. This can make it difficult for a Projector to get their ideas off the ground.

A Projector who offers up insight without being asked first may appear to others as bossy or controlling, even when they have the best of intentions. It can be very painful for a Projector to not have their wisdom recognized or appreciated. And eventually, they may become dejected or bitter.

However, a Projector who waits to be asked, recognized, or invited has an enormous amount of wisdom to share with the world. They can feel the energy of others in a deep way. Intuitively, Projectors know what the other energy types need to be doing to make the best use of their energy—particularly work force and life force energy.

Projectors who wait to be recognized by Generators have a vital piece in the puzzle of life. Remember, Generators without direction just do and do and do, without any real end result. The Projector who waits can share incredible insight that can turn the directionless busyness of the Generator into powerful energy that can accomplish great things.

It is crucial that we recognize and utilize the Projectors in our lives. They can be our most valuable resources.

However, the fear of the Projector is that if they wait, no one will ever ask

them their opinion. It is difficult to know the answer and to have to wait with your mouth shut, hoping someone will ask you. Remember, the aura does the talking. A Projector who waits will be asked by the right people who value their wisdom.

A Projector living his strategy is magnetic and attractive. People won't be able to stop recognizing and inviting the patient Projector. It is planetary geometry.

But, it is imperative that the Projector wait for the big invitations in life, such as love, marriage, career, moving, *etc.* A Projector who initiates any of this will most likely experience challenges and struggles.

Many Projectors find that they are unconsciously preparing for the next big invitation while they are waiting. Perhaps they are studying the very thing they will be invited into. Maybe they are investigating living in a certain region.

Projectors do better when they understand that their process will most likely seem slower than the process of those around them. Projectors must not compare themselves to the Generators and Manifestors in their lives. A Projector, by nature, will have a slower journey. But it is their own journey, and following their own path will give them sustainable energy and the recognition that will make their soul sing.

A Projector who is living his strategy is a beautiful thing to see; he knows that invitations and recognition will come from the people who value his wisdom and guidance.

Special Traits: Burnout

Projectors need help with recognizing when enough is enough. It is very easy for a Projector to take in Sacral energy and temporarily morph into a Super-Generator. But that is not sustainable.

Unlike Generators and Manifestors, the Projector has a finite amount of time and energy. Most Projectors can act like Generators until they crash around the age of forty.

Most burned out Projectors won't know what hit them. They will feel exhausted and depressed. Their bodies may be failing, and they might be struggling to make money and to keep their jobs. They may even lose important relationships and support.

It is crucial that a Projector experiencing burnout take some time to recuperate and simply wait for healing and an invitation. This can be challenging, as not many people have the financial means to simply quit

working. So they must work with the understanding that they are waiting for the right job, via invitation, and their interim job is simply to pay the bills until that opportunity presents itself.

The Projector's Health

Projectors are here to be wise about others. But their insight about other people sometimes leaves them blind to themselves and their own needs. They do not have the same capacity to know themselves the way a Generator does. Consequently, they need help seeing when they are overdoing it. They can even need help in recognizing when their bodies are not feeling or working well.

The Projector is not designed to work physically. Working out and exercise are not always suited to the Projector. Projectors do well with gentle workouts and must learn to honor their bodies and what they are feeling.

Because Projectors are so sensitive to the energy of others, they need time alone to discharge other people's energy out of their system just to feel physically good. This is not personal. It is just a necessity. Remember, the Projector is not hardwired to hold Sacral energy for prolonged periods of time.

Projectors may find that they need to nap during the day. They also need to rest before they can fall asleep. In order to protect their physical well-being, it is vital that the Projector goes to bed before she is tired. If she waits until she is tired, it's too late and the quality of her sleep will be poor.

Remember, the Projector sometimes needs help knowing when enough is enough. It is not uncommon for Projectors who are acting like Generators to stay up too late working and then battle insomnia even though they are exhausted. Projectors may also get better sleep if they sleep alone, particularly if their partner is a Generator.

Parenting the Projector Child

The greatest gift you can give a Projector child is recognition.

Here is an example of a common occurrence in a household with a Projector: A Projector child yearns to tell his mother all of his ideas. He is constantly expressing every thought he has, even if it may be at an inappropriate time. He can become frustrated and angry when she doesn't acknowledge his ideas, whether it is because she is busy or simply tired; and she in turn can become frustrated with her son for his inability to restrain himself.

But when the mother learns that her son is a Projector, she realizes he needs recognition for his ideas, and she practices asking him about them before he can

share his insights. This simple strategy shifts the dynamics of their relationship significantly.

Suddenly, the mother realizes that her son has some great insights, and she looks forward to listening to his opinions. Her son feels recognized and valued for what he has to share and finds it easier and easier to be quiet and wait for his mother to ask. He feels heard and seen for the first time in his life, and their relationship grows stronger and more respectful over time.

You can also help the Projector child in your life by facilitating opportunities for them. Remember that Projectors must not initiate. They truly need others to help them gain access to opportunities and energy. A Projector is not weak or lazy if they don't initiate action; they simply need the energy of others to help them get started.

Affirmations for the Projector

- I am a valuable resource for others.
- I am here to guide those who seek my wisdom, and I wait patiently for the right people to recognize what I have to offer. This helps me conserve my precious energy and feel valued and loved.
- When I am waiting for an invitation, the most important thing for me to do is to follow my passion.
- I never know what exciting opportunity will come my way. Fully engaging in my passion prepares me for my next adventure.
- I conserve my energy and use it wisely.
- It is okay for me to honor my own energy patterns. I don't have to keep up with others. I am unique.

The Reflector

Reflector audio download:
www.understandinghumandesign.com

The Reflector

Strengths

- Talkative
- Passionate
- Unique
- Proponents for peace and prosperity
- Reflect the health of their community

Weaknesses

- Highly sensitive
- Emotional theme: disappointment
- Need consistency
- Struggle to stay grounded
- Clingy

Besides having your type listed in the keynotes section of your chart, you can identify your type as a Reflector because:

- All nine centers on your chart are white (undefined).

See [figure 28](#) for an example of a Reflector's chart.

Representing less than 1 percent of the population, the Reflector is the rarest of the Human Design types. The Reflector is a truly unique, unusually sensitive person who must be in the right place with the right people to experience true happiness. A Reflector should be honored and valued by those around them, as they serve a truly unique role that can help the rest of us make decisions that can improve the welfare of all.

A Reflector has no inner authority. They can only know truth when they see it reflected through others. In an ideal society, we would have a collectively supported Reflector living with us and serving as a barometer for the health of our collective.

Reflectors can do anything provided they wait twenty-eight days to make good decisions. Reflectors talk a lot, and they need to talk to get clarity. The greatest gift you can give a Reflector is to listen to them.

The few Reflectors I have had the honor of meeting have been passionate souls who have had a deep sense of the pain and suffering on the planet. They have been strong proponents for peace and prosperity. Many of them have traveled around the world as guests and have been completely supported by the gifts and donations of others.

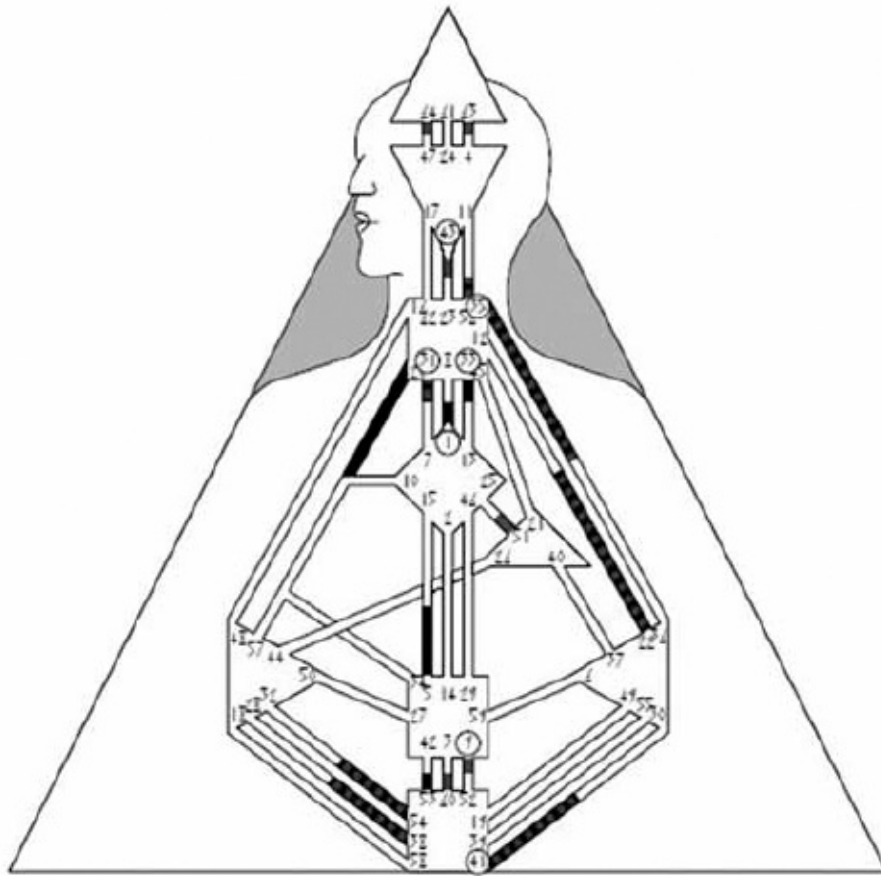

Figure 28: For the Reflector, all nine centers are white (undefined).

Reflectors are truly unique beings ruled by the magnificent moon. You can almost see the radiant light of the moon in their faces. May you find that all the Reflectors in your life are beacons of joy, and that bodes well for them as well as for us.

The purpose of the Reflector is to reflect the health of their community. A happy Reflector comes from a happy community. An unhappy Reflector lives in an unhappy community.

Because the nature of the Reflector is to be energetically reflective, the conditioning experience of the Reflector does not seem as harsh as it can feel for other types, especially the Projectors. Reflectors are designed to be deeply conditioned by their environment, and because they have such little consistency in their charts, they can reflect something new quite easily without much

trauma.

The Reflector's Chart

It doesn't take long to spot what is unique about the Reflector's chart. A Reflector has no definition in any of their centers and has an almost totally white chart. Because Reflectors have totally open centers, the gates in their charts are very important. Those energies are the only consistent energies in their charts.

The Reflector's Strategy: Wait Twenty-Eight Days

Reflectors are lunar beings. The moon makes a complete cycle through each of the sixty-four gates every twenty-eight days. As the moon moves through the chart of a reflector, it brings with it consistent changes in definition. Because of these consistent changes, a Reflector can anticipate energetic and decisive days based on their lunar cycle. The Reflector's strategy is to wait twenty-eight days (the cycle of the moon) to make a decision.

It is very helpful for a Reflector to get a Human Design reading. A reading will show the Reflector the exact changes in their chart over the twenty-eight days of their cycle so that they can know which days in their cycle are consistently for certain activities and decision making.

As you can imagine, needing to wait nearly a whole month to make sure your decision is valid can be difficult in our very fast culture. So it follows that the emotional theme of the Reflector is disappointment. Reflectors often experience disappointment in their decisions because they didn't wait long enough for clarity. They can regret their choices and be stuck with unhappy consequences because they were pressured to make a fast decision.

They also experience disappointment because, by virtue of their openness, the Reflector can be deeply wise about the extent of human potential, and they can so clearly see when humans don't live up to their potential.

While a Reflector is waiting out their twenty-eight days, it is important that they understand their need to talk about their decisions with others. A Reflector has no inner authority. They can only know the truth of their decision when they see it reflected through others.

It is vital for Reflectors that they have a consistent group of friends who make them feel good and who will listen and support the Reflector in their decision making. Because of the inconsistent nature of the Reflector's energy, Reflectors need consistent auras that they can rely on.

Reflectors also need to heed their only true inner authority, feeling good. When a Reflector feels good where they are, they are in the right place. If a Reflector does not feel good somewhere, whether they are in a restaurant or at their job, it is important for them to leave. If they are in a restaurant, they can leave immediately; but when leaving a job, it's good practice to take a full twenty-eight days to be sure that leaving is the correct decision.

Once the Reflector waits twenty-eight days to make a decision, then they can do whatever they need to do to act on that decision. If they need to quit, they can just quit. If they need to move, they move. No more waiting is required after that.

Although they can need a lot of alone time to discharge excess energy, especially Sacral energy, Reflectors also need others. A quiet, hermetic life is not correct for the Reflector. In a perfect world, we would all know who the Reflectors are in our community and would make sure they are feeling good and happy, because their happiness reflects the happiness of the community.

Special Traits: Inconsistency and Sensitivity

Because the Reflector experiences so much energetic change from within and from others, every day in the life of a Reflector can be inconsistent and volatile. It's hard for a Reflector to know what is stable and reliable. The only solution is to take time with all choices and to make sure to “bounce” ideas off trusted friends and family. Of course, taking long periods of time to gain clarity isn't always easy to do in our culture, and the Reflector is often pressured to make quick decisions that end up being incorrect and disappointing.

Reflectors have a deep awareness of the full potential of humankind. What happens in the “real” world can impact a Reflector deeply. War, suffering, and injustice can truly tear at the Reflector's spirit, and traumatic global events can cause the Reflector tremendous pain. It's important for Reflectors to watch their mindset and to find a strategy, like the Emotional Freedom Techniques (EFT), to cope with the disappointment and pain they experience.

The Reflector's Health

As with all other non-Sacral types, the Reflector may have trouble sleeping. Making sure that the Reflector gets time supine in bed before falling asleep is important for good health.

As the Reflector is quite open, he also needs significant alone time to discharge the extra energy from his body. Remembering alone time is

sometimes challenging for a person who needs and is designed to be with others, but it is healthy.

Although a Reflector can have more energy than any other person due to their open nature, they do not have within them any inherent consistent energy. Because of this, hard physical exercise or labor is not correct for the Reflector. Again, what feels good is probably good for the Reflector as long as they remember when enough is enough and do not overwork themselves.

Because the Reflector is here to reflect the health of others, they may not always be able to see their own health. Because of this, Reflectors need consistent people in their life who know them and can help them recognize if they become ill. When a Reflector becomes ill, it is important, of course, to take care of their body, but it is also vital to look at the community to see if there isn't also something within the community that is making the Reflector ill.

Parenting the Reflector Child

Reflector children need consistency and do not transition easily. Because they have open Spleen and Identity Centers, it is common for Reflector children to seem clingy and to need their parents close by.

Remember that feeling good is truly the authority for the Reflector. If they feel good, then they are in the right place. As a parent, you may have to move your Reflector child around a bit until they find a place that feels good to them. Because of this, a Reflector child will want to be in school, but be aware that if there is unrest or problems in the energy of the classroom, your child may reflect that energy and complain.

Reflectors will also reflect their friends. Reflector children must have friends who feel good, too. Remember that your child will be a reflection of their peer group. If you do not feel good about your child's peer group, you may want to gently work with your child to help them make better friends.

Affirmations for the Reflector

- I am a reflection of my world around me. If I feel good, I am in the right place. If I don't feel good, I need to change my location.
- I honor myself enough to take as long as necessary to make good choices. I discuss my options with my close friends, and I listen carefully to their feedback and sense if it feels correct for me.
- I am sensitive to the world around me. I can experience the pain and suffering of others deeply.

- I have consistent strategies to help me cope with intense feelings of disappointment with the world. I seek solace and find joy in nature, in animals, and with children who help me restore my spirit.

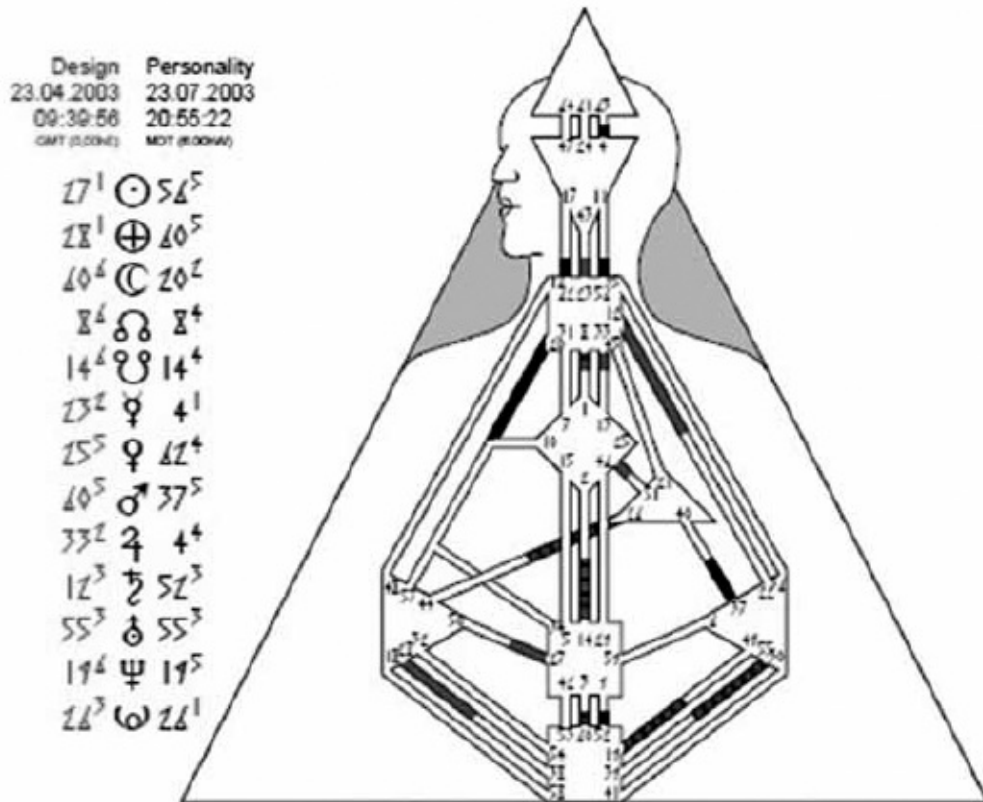

Your Individual Design Keynotes

DEFINITION TYPE: No Definition

TYPE: Reflector
 Theme: Disappointment
 Strategy: Simply Wait (28 day cycle)

AUTHORITY: none

PROFILE: P 5 / D 1
 Left Angle - Trans-Personal Karma:

Figure 29: Reflectors have no true authority because all of their

centers are undefined.

Authority

Manifestors, Generators, Manifesting Generators, and Projectors have authority in their charts. Reflectors, because they have no centers defined in their charts, have no true authority other than their Reflector strategy ([figure 29](#)).

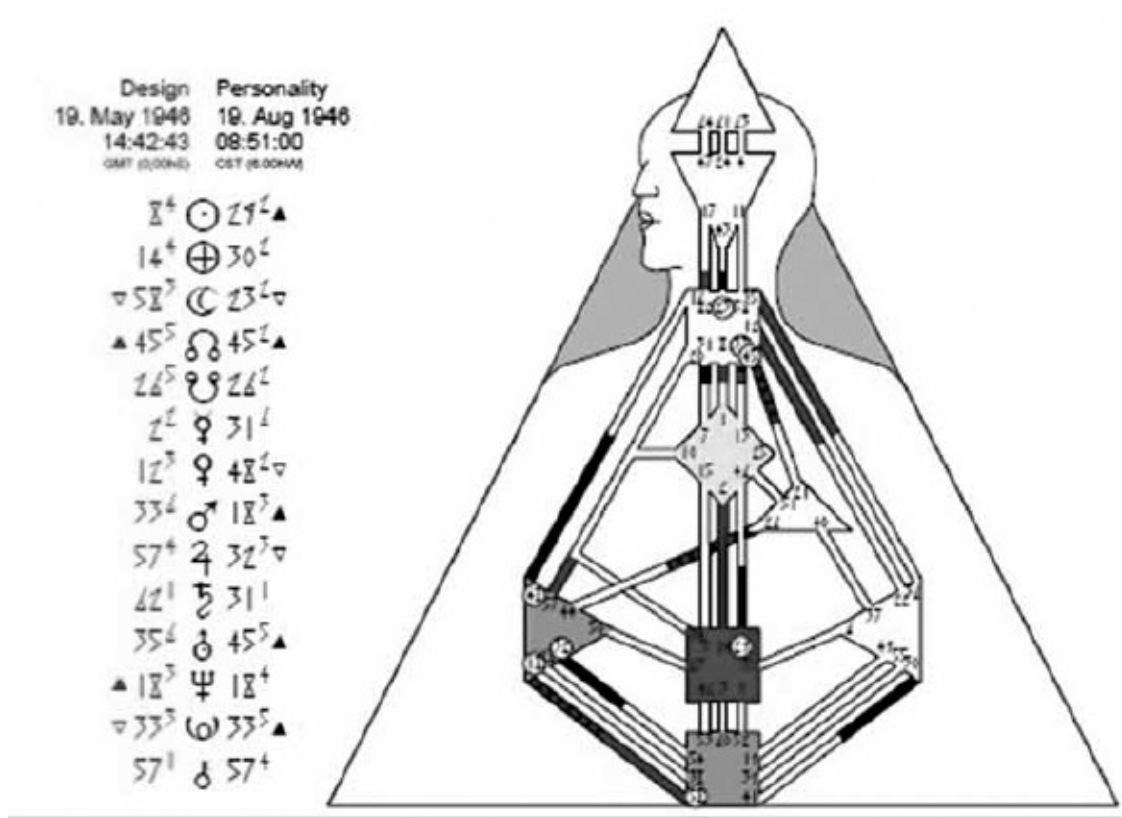

Your Individual Design Keynotes

TYPE: Generator

Theme: Frustration

Strategy: Wait to Respond

PROFILE: 2 / 4 Hermit Opportunist

29-30 / 8-14 : The right angle cross of Contagion (3)

Right Angle - Personal Destiny:

DEFINITION: Split Definition

AUTHORITY: Sacral Expressed Generated

Figure 30: Generated, or Sacral, authority

Generated Authority

Generated authority means that you have a defined Sacral Center and that there are no additional energies influencing your Sacral. Your Sacral is the only decision-making center in your chart, and your Sacral response in the moment is the correct authority for you at any given point in time ([figure 30](#)).

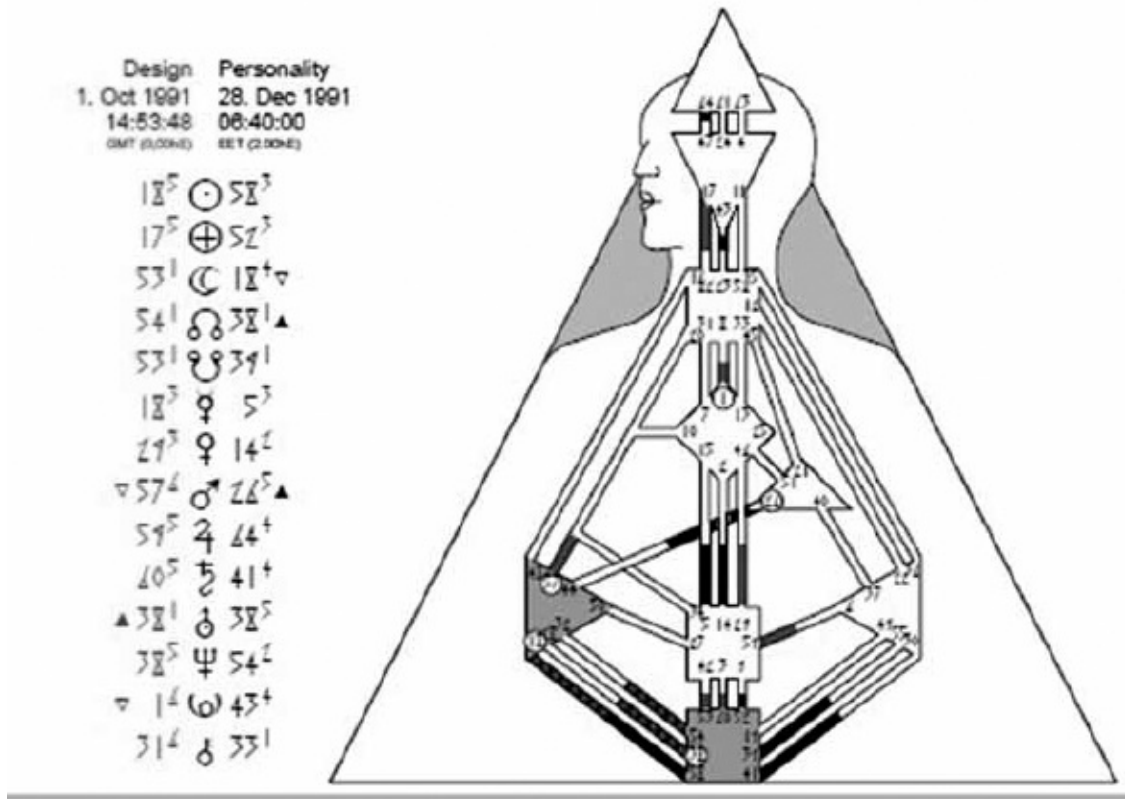

Your Individual Design Keynotes

TYPE: Projector
 Theme: Bitterness
 Strategy: Wait to be invited

PROFILE: 3 / 5 Martyr Heretic
 58-52 / 18-17 : The right angle cross of Service (4)
 Right Angle - Personal Destiny:

DEFINITION: Single Definition

AUTHORITY: Splenic Awareness Projected

Figure 31: Splenic authority

Splenic Authority

The spleen is the center for survival, time, health, and intuition. Because it is the energy for basic survival, it is very time-centered and always operates with an intuitive pulse in the moment. You trust your gut and act on it. This is pretty easy for Manifestors and Projectors, but sometimes it can be confusing for

Generators, who may wonder if their spleen overrides their Sacral response. For Generators with splenic authority, their Sacral response in the moment is correct. Your spleen and your Sacral work together ([figure 31](#)).

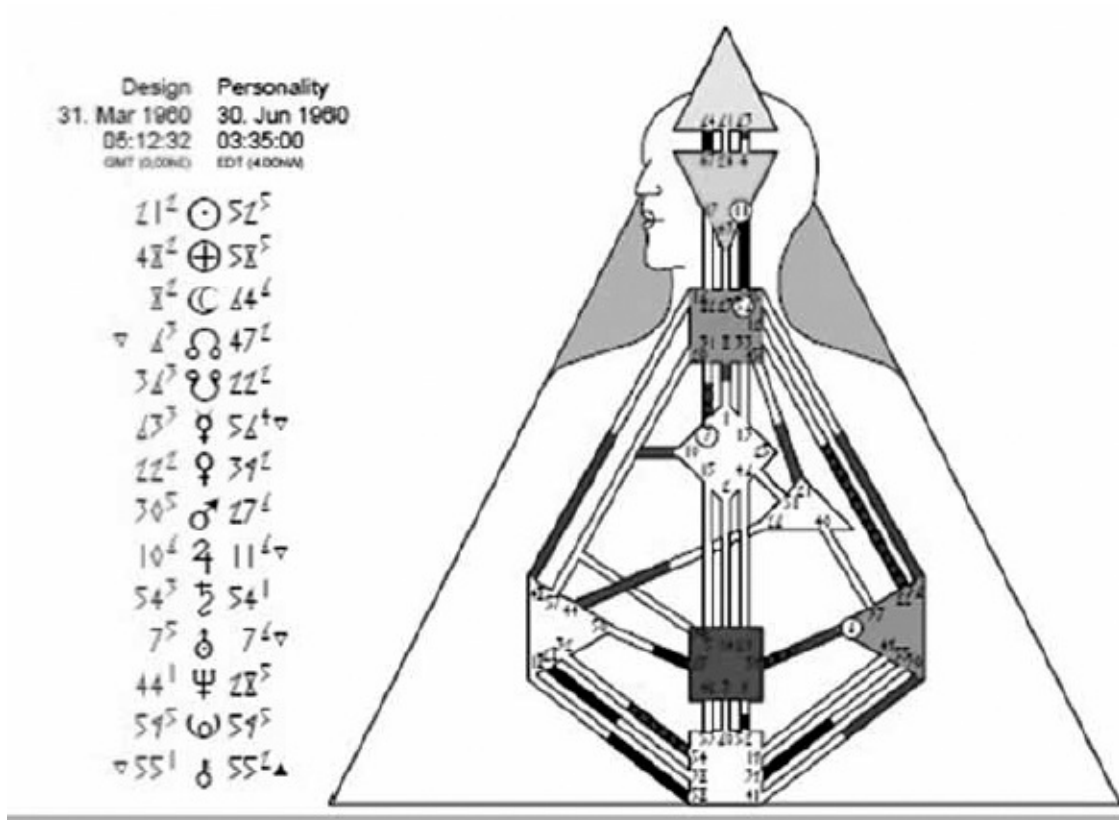

Your Individual Design Keynotes

TYPE: Generator
 Theme: Frustration
 strategy: Wait to Respond

PROFILE: 5 / 2 Heretical Hermit
 52-56 / 21-48 : The left angle cross of Demands
 Left Angle - Trans-Personal Karma:

DEFINITION: Split Definition

AUTHORITY: Emotional Solar Plexus

Figure 32: Emotional authority

Emotional Authority

When you have a defined Emotional Solar Plexus, it will dramatically influence your strategy. The defined Emotional Solar Plexus is a motor with energy that pulses in waves. If you are emotionally defined, you probably know that you have moods or changes in your emotional energy pretty regularly ([figure 32](#)).

It's pretty common for emotionally defined people to be terrified of making decisions. They often have a history of enthusiastically leaping into decisions and then waking up a few days later only to find that their mood has shifted and now they are obligated to finish a project or a relationship that they just aren't in the mood for anymore. Understanding emotional authority will help you make better choices and significantly improve your chances that your mood won't affect your commitments.

If you have a defined Emotional Solar Plexus, you are not here to be spontaneous, though others will often put pressure on you to leap into things. Leaping into things without waiting for clarity will only create chaos in your life if you have emotional authority.

When you have emotional authority in your chart, you still use your strategy, but you need to wait until it feels right.

Ego Authority

Only Manifestors have ego authority. Ego authority is when your Will Center is connected via a colored channel to your Throat Center ([figure 33](#)).

With ego authority, you don't have to wait for anything before you take action. The one caveat with this is making sure that you are well-rested and ready to take on the world. A defined ego is designed to have cycles of work and rest. It's easy with the willpower of the ego to push through burnout and actually damage your health. If you have ego authority, check in with yourself to see if you need some downtime before you leap into the next commitment.

Self-Projected Authority

Only Projectors have self-projected authority. Self-projected authority comes from a channel connecting the Identity Center to the Throat Center with no other overriding energies defined in the chart, such as the Solar Plexus or the Spleen ([figure 34](#)).

Self-projected authority means that you have to “see” your decisions reflected or projected through others to get clarity. In order to really know what

is correct for you, you need to have a circle of close friends who you can talk to about your choices. You need to hear yourself talking to others and see their response to know whether something is correct for you or not.

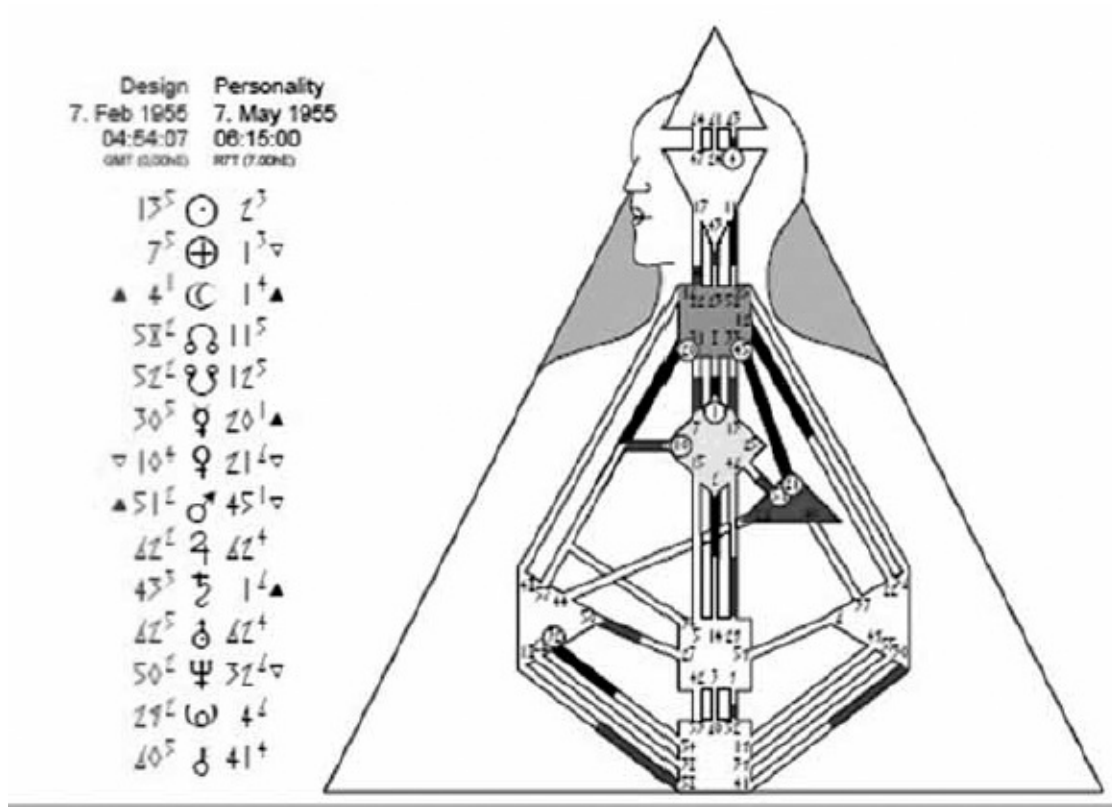

Your Individual Design Keynotes

TYPE: Manifestor
 Theme: Anger
 Strategy: Inform before you act

PROFILE: 3 / 5 Martyr Heretic
 2-1 / 13-7 : The right angle cross of the Sphinx (2)
 Right Angle - Personal Destiny:

DEFINITION: Single Definition

AUTHORITY: Ego Manifested

Figure 33: Ego authority

This does not mean that you have to follow the advice of your friends or

family. You may disagree with their thoughts or opinions. But you do need to hear your own thoughts and opinions projected through others. You'll get clarity from sharing your choices in conversation.

Mental Projected Authority

Mental projected authority is also only experienced by Projectors with a defined Ajna to the Throat Center and no other overriding energies. Mental projected authority, just like self-projected authority, means that you have to talk to other people to get clarity about which invitations are right for you ([figures 35](#) and [36](#)).

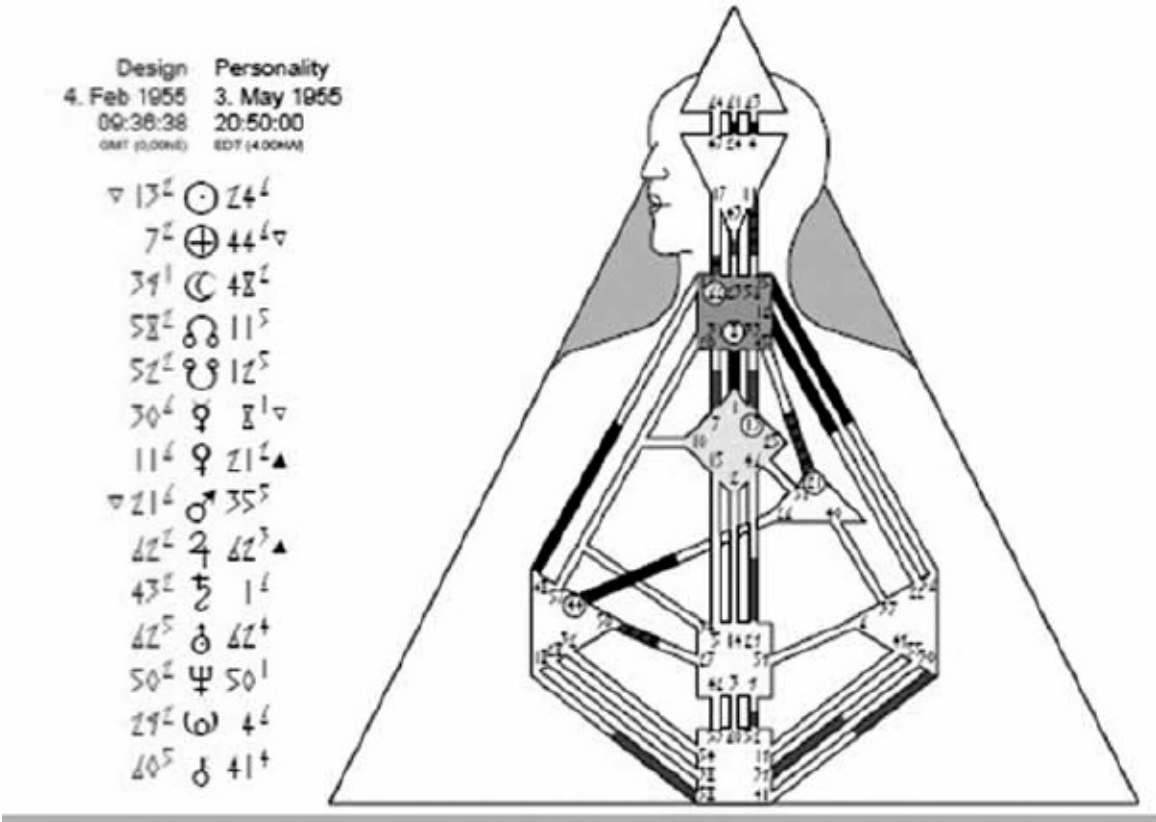

Your Individual Design Keynotes

TYPE: Projector
 Theme: Bitterness
 strategy: Wait to be invited

PROFILE: 6 / 2 Role Model Hermit
 24-44 / 13-7: The left angle cross of incarnation
 Left Angle - Trans-Personal Karma:

DEFINITION: Single Definition

AUTHORITY: Self Projected

Figure 34: Self-projected authority



As you can see, each one of us has a unique strategy for creating and

experiencing the world. Knowing your type and strategy is the most important information you need to know in Human Design. If you follow your strategy according to your type, your life will invariably improve and become an expression of who you truly are.

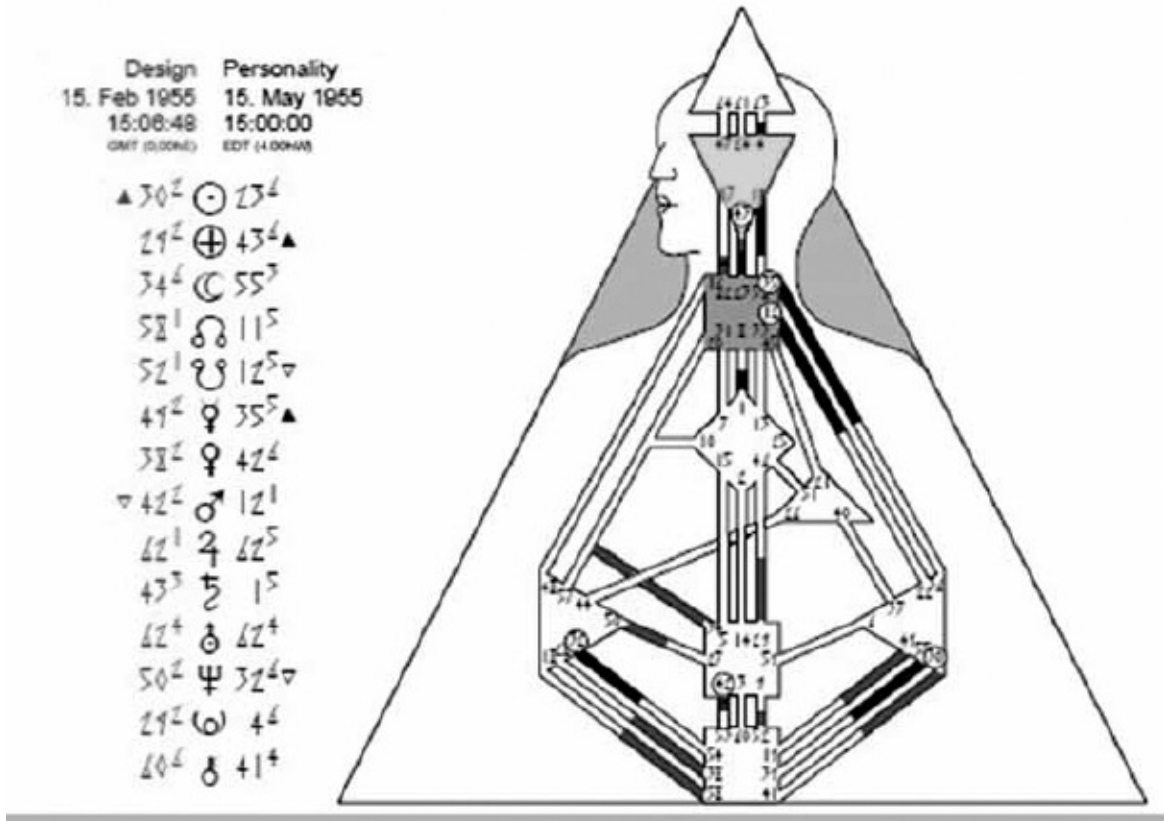

Your Individual Design Keynotes

TYPE: Projector
 Theme: Bitterness
 Strategy: Wait to be invited

PROFILE: 6 / 2 Role Model Hermit
 23-43 / 30-29 : The left angle cross of Dedication
 Left Angle - Trans-Personal Karmas:

DEFINITION: Single Definition

AUTHORITY: none

Figure 35: Mental projected authority

It's important to note that while each one of us is different and magnificent, it is truly in the sum total of the parts of who we are as humans that the true elegance of Human Design and humanity is revealed. We need each other. And our unique energies are created to come together in service to one another.

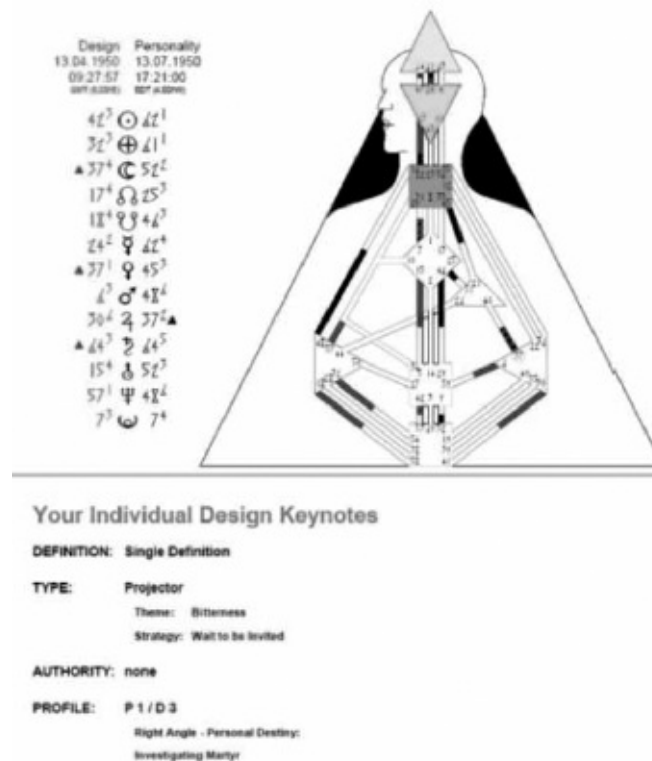

Figure 36: Another example of mental projected authority

When you understand your type and the types of those you love, it empowers you to create relationships that are honoring and authentic. The most common thing my Human Design clients tell me is that not only did their experience with their own design open up their world, but it helped them stop judging others and truly see them for who they are. The world needs more of that, don't you think?

Chapter 3

The Nine Centers

Each center is responsible for processing specific energies.

Defined centers have fixed and consistent energy. This energy will always be there for you and radiates out to impact others. Defined centers have their own issues, but in general they are much easier to deal with than the sometimes traumatic experiences of open centers. To live out the beauty and the deep impact of your defined centers, you have to live your Human Design strategy. It will empower you to always know what to do.

Open centers are white, undefined, mutable. The energy here is inconsistent and depends on your environment and mood. In each of the following sections, there is an affirmation and a question to help you manage your open centers. Understanding the questions of the open centers will empower you to work with your energy instead of being victimized by the energy you take in.

Let's take a closer look at the nine centers and their characteristics.

The First Center: The Head

“My head is all white.

Am I mindless?”

Head Center audio download:

www.understandinghumandesign.com

The Head Center appears at the top of the body graph. Its symbol is an isosceles triangle ([figure 37](#)).

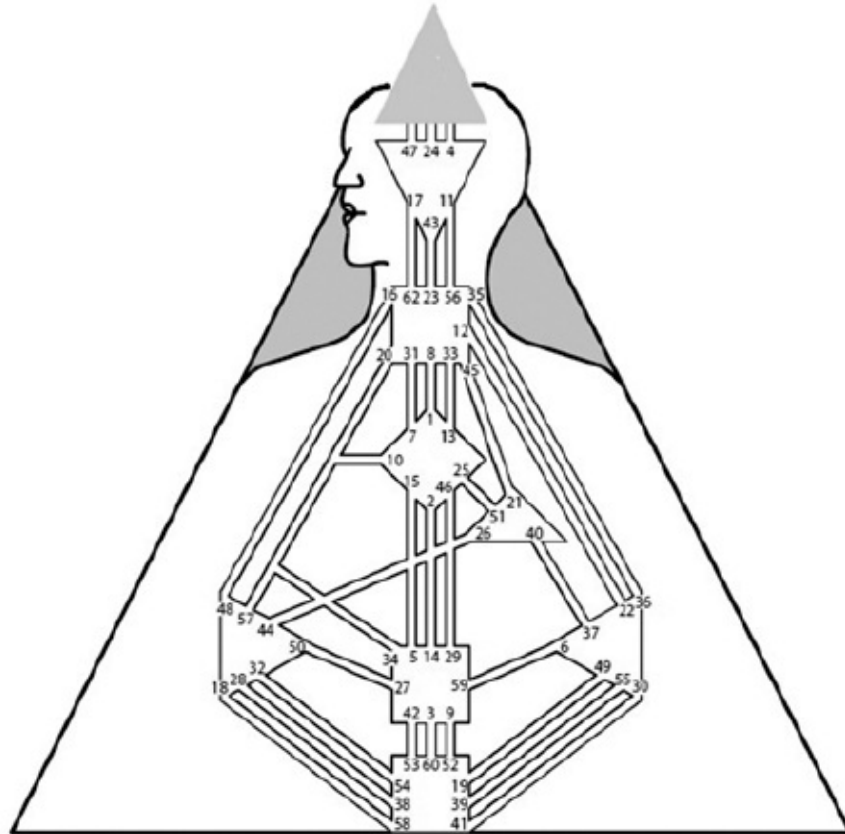

Figure 37: The Head Center

The Head Center is associated with the pineal gland in the brain. It is the center for inspiration, and it is always under pressure to answer questions. Depending on the gates that define the center, the questions the head center answers can be abstract, logical, or individual in nature. It is not motorized, but it is a pressure center.

The Open Head Center

Someone with an open Head Center does not have a consistent way to receive inspiration, so when they come across inspiration they will take it in and amplify it.

It is very easy when you have an open Head Center to feel inspired all the time. Not only do you feel inspired, but you also feel pressure to act on this inspiration. This can make it look as if you don't know what you're doing or you are leaping all over the place trying all kinds of different things. People may even say that you just need to be decisive, pick one thing and stick to it. Those who understand their open Head Center can have a very deep understanding of

who and what is truly inspiring. They can be wise about which inspirations to take action on and which to simply observe.

Not only will someone with an open Head Center have the ability to take in the inspiration of the world and amplify it, but they will also take in all the questions of the world and amplify those, too. This can sometimes make it difficult to make decisions. For example, let's say you are going out to eat. Earlier, you had a strong craving for a grilled cheese sandwich. But now that you are at the restaurant, your head is flooded with all kinds of inspiration, especially from the people sitting next to you, and instead of ordering a grilled cheese sandwich, you order shrimp cocktail. The shrimp arrives, and you spend the rest of the meal wondering why you ordered that.

You may be flooded with inspirational energy, but the only thing you really need to do to make good decisions is to follow your strategy for your type.

QUESTIONS FOR THE OPEN HEAD CENTER

- Do you feel as though you are always under pressure to answer other people's questions?
- Do you find yourself frequently living out other people's ideas and inspirations?

AFFIRMATIONS FOR THE OPEN HEAD CENTER

- I am deeply inspired all the time.
- I follow my strategy to help me decide what I need to do.
- The questions in my head are from others; I don't have to answer all of them—only the ones that truly inspire me.

The Defined Head Center

A defined Head Center is colored in yellow. Because the energy in the defined Head Center is always “on,” people with defined Head Centers are inspirational forces on the planet. They are always radiating inspiration out into the world. They may not always be aware of it, because it is energetic, but it's happening.

Defined Head Centers have a consistent source of inspiration. They are always asking questions and may feel that something is wrong if they don't have an answer. Inspiration is a reflective process. If you have a defined Head Center, it is important to process the questions you are receiving, but don't rely on the answers to make decisions about your life.

Often, people with defined Head Centers don't realize that they are questioning things. You may even find that they seem to have permanent quizzical looks on their faces. It is simply a part of their consistent energy.

AFFIRMATIONS FOR THE DEFINED HEAD CENTER

- I am inspired and inspiring.
- I spread inspiration everywhere I go, sharing my ideas and insights with others.

When Defined and Undefined Head Centers Meet

When someone with a defined Head Center enters into the aura of an undefined Head Center, the defined Head Center will “deposit” a question into the other's mind. The undefined Head Center will pick up the energy of the question, amplify it, and spend the rest of the day wrestling with a question that wasn't even theirs in the first place.

When parents with defined Head Centers have children with undefined Head Centers, the kids can seem like they are full of questions. The children are just amplifying your own questions, whether you are aware of it or not.

The Second Center: The Ajna

“Thinking is mutable and unlimited.”

Ajna Center audio download:

www.understandinghumandesign.com

Based in the anterior and posterior pituitary in the brain, the Ajna is an awareness center ([figure 38](#)). Its function is to research and to conceptualize.

The Open Ajna Center

Someone with an open Ajna Center can see many sides to an issue. They are fair, judicious, empathetic, open-minded. An open Ajna can be very intellectual. An open Ajna doesn't have a fixed way of thinking, so they are able to process and understand information in a myriad of ways. People with an open Ajna who

are able to relax can become great mind readers.

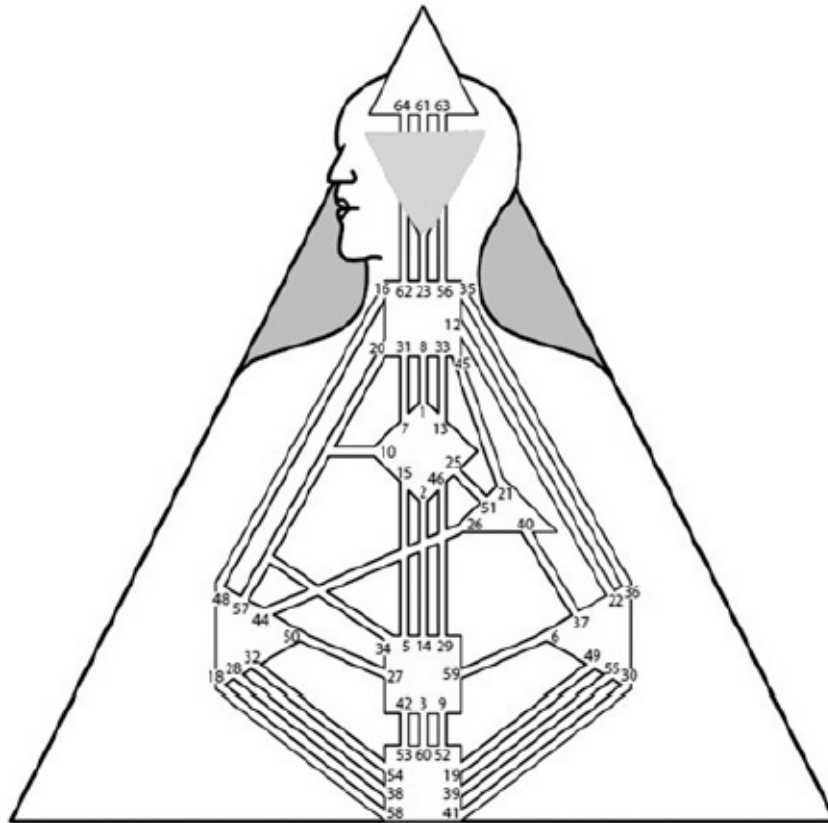

Figure 38: The Ajna Center

Because the open Ajna is designed to take in information and ideas and see all the different layers and levels of understanding, it can be a challenge for an open Ajna to “lock on to” a fixed idea or belief. With great effort people with open Ajnas can hold a fixed idea, but it doesn't come easily or naturally. If you have an open Ajna, you may have been told that you need to just make up your mind about something and stick to it. Remember that you are here to be wise about ideas and beliefs, but not necessarily adopt them. The beliefs that you hold on to will be the ones you came to through using your Human Design strategy and authority.

QUESTION FOR THE OPEN AJNA CENTER

Do you struggle with feeling confident in your decisions?

AFFIRMATIONS FOR THE OPEN AJNA CENTER

- I am wise about information and beliefs.
- My gift is that I can see many sides of an issue and have many different understandings that are fluid and change all the time.
- I don't have to make up my mind.
- I always write down things I want to remember.

The Defined Ajna Center

The defined Ajna Center is colored in green. The defined Ajna is designed to hold information. It is trustworthy and reliable, but it is fixed in how it works. It is important to note again that the mind is a great resource, but it is a terrible place to make decisions. Remember that no decisions should come from the mind.

AFFIRMATIONS FOR THE DEFINED AJNA CENTER

- I am gentle with my thinking and always strive to remember that there are many ways to think about information.
- I am uniquely capable of being certain.
- I listen carefully to the thoughts of others and allow for limitless thinking with grace.

When Defined and Undefined Ajna Centers Meet

When a defined Ajna steps into the aura of an undefined Ajna, the undefined Ajna, without awareness, can think that the thoughts of the defined Ajna are their own. A child with an undefined Ajna who lives with a parent with a defined Ajna may experience a lot of mental pressure to be consistent. But they can't. An undefined Ajna can be mentally inconsistent. All the information that they receive is secondhand. This can feel very uncomfortable for the child if they are pressured by their parent to “think like me.”

The Third Center: The Throat

“Words when spoken carry power. Speak with great care and responsibility, and honor the energy of the spoken word.”

Throat Center audio download:

How many times have you been frustrated or discouraged because you feel as though no one is listening to you? Are you the life of the party, but you go home with a sore or raspy throat? Were you the child who got in trouble all the time in school for talking too much? These are some of the things that can happen when you fail to live out the correct strategy of the throat center.

The Throat Center represents the thyroid and the parathyroid. On the body graph, the Throat Center is the square underneath the Ajna and the Head Centers ([figure 39](#)). The Throat Center is the center for communication, as well as manifestation into action.

The Open Throat Center

How your Throat is defined will control how you speak. People with undefined, or open, Throats always feel under pressure to speak. When they are in a group or in school this can be very difficult. The open Throat often blurts out comments or answers—sometimes uncontrollably, unaware of where the comment came from (this is even worse if your mind is also undefined).

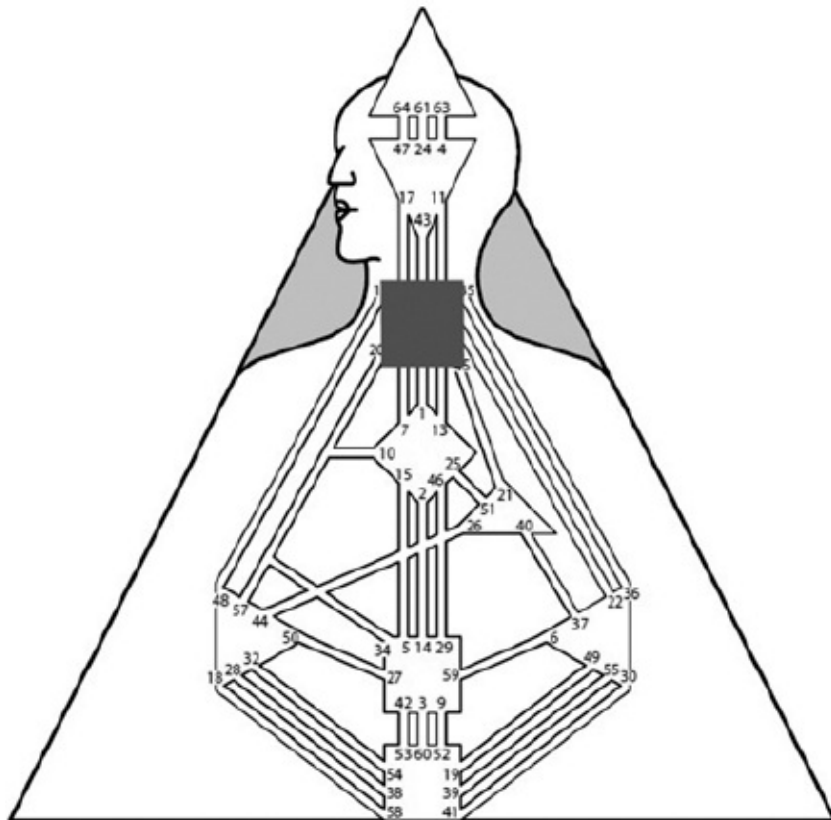

Figure 39: The Throat Center

There is, however, deep wisdom in the open Throat. Many great singers (like Celine Dion) and well-known speakers (like Bill Clinton) have open Throat Centers. Someone with an open Throat can speak in various ways depending on who they are with. The open Throat can be very good at speaking foreign languages and impersonating others' speech.

In order for the open Throat and the thyroid to remain healthy, it is important to speak according to your strategy. I always encourage open Throats to experiment with not talking. Try going to a party or gathering and don't say a thing unless you're given something to respond to or you are invited into a conversation. If you are silent, your aura does the talking! Just wait and see. People won't be able to stop themselves from talking to you!

QUESTION FOR THE OPEN THROAT CENTER

Are you trying to get attention so you can be heard?

AFFIRMATIONS FOR THE OPEN THROAT CENTER

- My words are heard best when I am invited to speak.
- I save my words for people who will truly value my words and point of view.

The Defined Throat Center

The defined Throat is colored in brown. The defined Throat Center is designed to speak, but how it speaks is controlled by what it is connected to. Understanding where the Throat is connected is vital to understanding how you relate to others. For example, if your Throat is connected to your Ajna, you can speak your mind. If your Throat is connected to your Emotional Solar Plexus, you are able to talk about your feelings effectively.

For the defined Throat to be heard, it is vital that they enter into communication according to their strategy: Manifestors and Manifesting Generators can just talk, Generators need to respond, and Projectors need to wait to be invited to speak. Reflectors will never have a defined Throat Center.

Effective communication is vital for personal and global well-being. Experiment with living your strategy and see how it improves the quality of your relationships.

When Defined and Undefined Throat Centers Meet

In my practice I often have romantic partners complain that the other partner just won't share their feelings. When I look at each of their Human Design charts, almost always the “unemotional” partner has no channels connecting their Emotional Solar Plexus to their Throat. I advise these couples to discuss their feelings in a semi-public place, like a restaurant, where they can hook up with other auras to get the connections they need to communicate more effectively.

AFFIRMATIONS FOR THE DEFINED THROAT CENTER

- I speak with great responsibility and know the true source of my words.
- I allow others to have a voice and use my words to invite others to share.

The Fourth Center: The Identity

“Who are you?”

Identity Center audio download:

www.understandinghumandesign.com

The Identity Center is one of the most important centers in the Human Design system. It is the center for love and direction, the place where the soul is seated. The liver is represented by this center. The Identity Center, sometimes called the “G-Center” or the “Magnetic Monopole,” is the diamond in the middle of your Human Design chart ([figure 40](#)).

The Open Identity Center

Individuals with an open Identity Center understand other people's sense of self and direction. They will take in another person's identity and amplify it, giving them insight into another person's perspective. I have known many therapists, teachers, and intuitives with open Identity Centers.

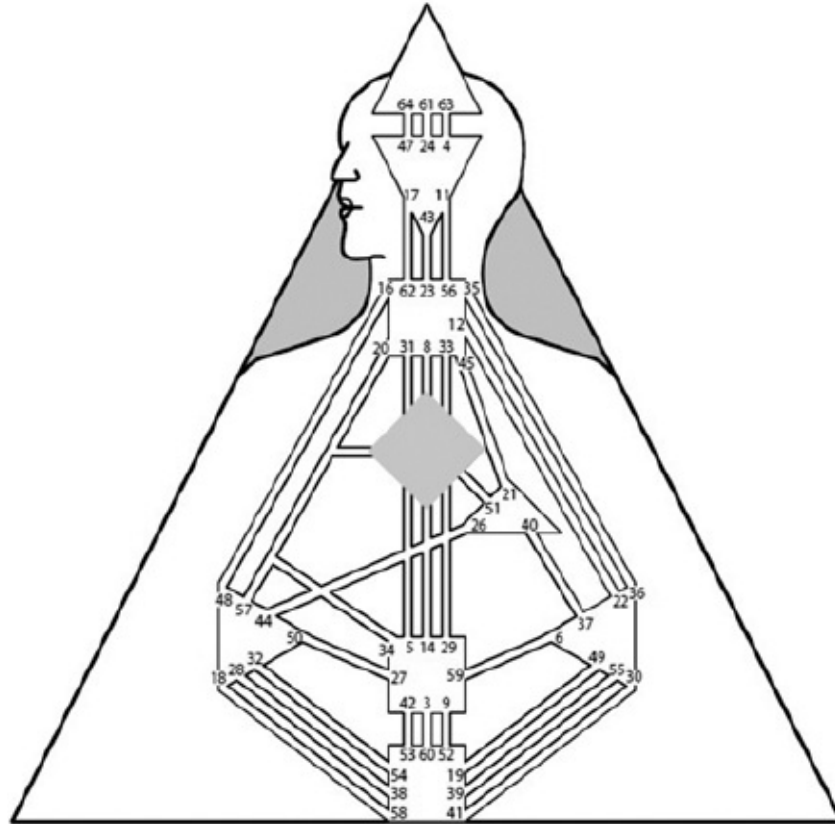

Figure 40: The Identity Center

Because this is the center for direction, being in the right place at the right time is the most important thing for individuals with an open Identity Center. My clients with open Identity Centers will tell me that they will experience a “click” on a cellular level when they are in the right place. It is almost as if they feel a deep sigh of relief when they are in the right town, the right restaurant, the right office. Being in the right place allows these individuals to receive the right opportunities.

Conversely, if a person with an open Identity Center is in the wrong place, they will also feel it on a deep, deep level. When they are in the wrong place, they may get all the wrong opportunities—or none at all.

How people with an open Identity Center express themselves may change depending on who they are experiencing at the moment. This is important especially if you are the parent of a teenager. Children with open Identity Centers may appear more vulnerable to peer pressure and may seem more apt to assimilate into being part of a clique.

Because a person with an open Identity Center has a dynamic sense of

themselves and their own personal direction, often these individuals can be afraid that they are not lovable. Who they perceive themselves to be is always changing, and therefore how they receive love is also always changing. For this reason, children with an open Identity Center may also sometimes be a little bit more vulnerable to self-esteem issues. It is common for parents of a child with an open Identity Center to long for the child to “find himself.” These children are not here to find themselves; they are here to be wise about experiencing others.

I advise those with an open Identity Center to throw a party. With an unlimited capacity to experience others, individuals with open Identity Centers tend to have all kinds of friends from all walks of life. A drug dealer and a district attorney? Why shouldn't these two mix? The open Identity Center person is friends with both. It is a fascinating study in humanity to see who comes to an open Identity Center's party.

QUESTIONS FOR THE OPEN IDENTITY CENTER

- Do you notice that you tend to adopt the personalities of those around you?
- Do you question your lovability?

AFFIRMATIONS FOR THE OPEN IDENTITY CENTER

- How I experience myself changes depending on who I am with. Knowing this, I choose to surround myself with people who feel good to me.
- Place is very important to me, and I create an environment that soothes me.
- When I am in the right place, the right opportunities come to me.

The Defined Identity Center

When you have a defined Identity Center, you are here to give love. Your sense of yourself is probably pretty solid. While you know who you are and where you are going, you might not always know how you are going to get there.

Individuals who have a full channel connecting their Identity Center to the Throat Center can be very vulnerable to criticism, as their creative expression comes straight from their identity.

When Defined and Undefined Identity Centers Meet

When a defined Identity Center meets an undefined Identity Center, the open

person will take in the identity of the defined person. When you have awareness of your openness, you can understand that you are experiencing the identity of the other person and appreciate who they are. While this is an ideal configuration because the open person can “morph” themselves somewhat to be like the other person, the trick is staying true to yourself when you are open.

The biggest challenge I see with couples with this configuration is that the open Identity often struggles with taking direction, especially in the relationship. The defined partner is really better at giving the relationship direction. But this gets tricky, especially if you have a gender-based belief system that men should lead. If the man has an open Identity Center, it may be harder for him to give direction in the relationship. Letting go of these traditional gender stereotypes helps.

It's also important for the open Identity to not get “lost” in the relationship. Of course, to make sure the relationship is taking direction, follow your strategy according to your type.

AFFIRMATIONS FOR THE DEFINED IDENTITY CENTER

- I am who I am.
- I express myself in all that I do.
- I celebrate the magnificence of who I am.

The Fifth Center: The Will

“The secret to willpower is having some.”

Will Center audio download:

www.understandinghumandesign.com

The Will Center is the small triangle located to the right of the diamond in the middle of the chart ([figure 41](#)). It is the center for the heart, the stomach, the gall bladder, and the thymus. It is also one of the four motors.

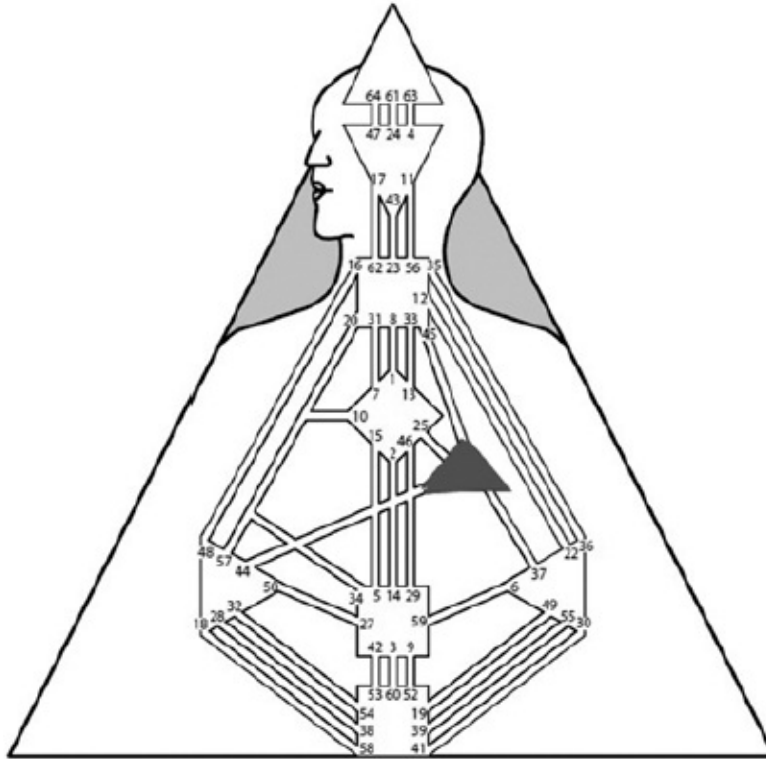

Figure 41: The Will Center

The Will Center is the motor that is responsible for bringing things forth on the material plane. It is part of the business circuitry in the Human Design system, and energetically it is all about value, business management, allocation of resources, and the energy to get things done even when the going gets tough.

The Open Will Center

How many times have you tried to do something like stay on a diet, quit smoking, or exercise regularly? How much energy do you use every day trying to do all the things you think you should do or that you promised to finish?

Okay, it's time to be honest with yourself here. You don't have willpower. And that is not a personality defect. You can take comfort in the fact that most people don't have willpower. Most people (about seven out of eight) do not have a defined Will Center, and therefore do not have consistent access to willpower.

When you have an open Will Center, it is crucial that you use your strategy to make agreements and promises. If you don't, you will be using energy you don't have and run the risk of entering into the wrong situations and feeling

obligated to make yourself follow through. And you might miss the right opportunity, because you will be busy forcing yourself to do something you don't want to do.

Because the Will Center is also all about value and the material plane, it is also very common that you may have a tendency to undervalue yourself. It is common for people with open Will Centers to undercharge for their business services or even give their services away, even when no one asks them to. I always encourage my clients with open Will Centers to check out the going rates for their services and make sure that they are charging enough. If you are employed by someone else, make sure that you are being paid what you are worth.

Because the open Will Center can be motivated by a need to prove itself, I also suggest asking what you are trying to prove when you make a new agreement. Are you trying to prove that you are nice? Are you trying to prove that you can do more than everyone else?

Remember that the open centers are our deepest sources of wisdom. The open Will Center can help you become very wise about what is truly valuable in life. You may, with time and experience, become very wise about what you are worth, both in the business arena and in your personal life. You may also become wise about knowing when it is time to work and when it is time to rest.

Many of you might be wondering, If I don't have willpower, how will I get things done? You can and do get things done, but you have to enter into each of your commitments according to the strategy for your type. When you have an open Will Center, it is very important for you to understand that following your strategy may save your life. We are all conditioned to believe that we have willpower. We are the "just do it" society. And, of course, if we force ourselves to "just do it" outside our strategies, we fail and end up feeling lousy and burned out.

For example, let's say you are a Generator and you notice that your neighbor is getting ready to paint his house. You strike up a friendly conversation, and all of the sudden you find yourself offering to get up early and help your neighbor paint. Of course, your neighbor accepts the generous offer. The next morning you wake up regretting having made the offer and look for some acceptable ways to get out of your commitment. You think about pretending to be sick or even telling some other lie. But your conscience gets the best of you, and you go next door to help.

That night you go to bed very sore and very tired and have a miserable time regaining your strength and stamina after working so hard. Your neighbor is

also tired and a little frustrated, because you didn't help him exactly the way he had imagined, and now he has to secretly go back and redo the work that you helped him with.

Remember that the Generator strategy is to wait to respond or give others something to respond to. You did not enter into this helpful agreement with your neighbor according to strategy, and, consequently, the whole thing went awry. And because you don't have willpower, you forced yourself to do something that didn't feel right in the light of day, and you burned yourself out.

How different would the situation have been if you had waited for your neighbor to ask for help or if you had asked your neighbor if he wanted help (responding or giving someone something to respond to)? You might not have entered into an agreement that you then felt obligated to follow through on. Your Sacral response would have protected you from making the wrong commitment or promise.

QUESTION FOR THE OPEN WILL CENTER

What are you trying to prove?

AFFIRMATIONS FOR THE OPEN WILL CENTER

- I make promises very deliberately and only according to my Human Design strategy.
- I have nothing to prove, and I value myself deeply.
- I ask to be paid what I am worth, fearlessly and confidently.

The Defined Will Center

A defined Will Center will always be red on your chart. When you have a defined Will Center, you have consistent access to willpower. You can be willful.

If you have a defined Will Center and you decide that you would like to start running every morning, it will be pretty easy for you to get into a regular routine and make yourself run every day, even if you don't feel like it. You might pause your routine for a few days to rest, but you'll pick it back up in a few days and stick with it consistently.

When you have a defined Will Center, it is very important for your self-esteem to make promises and keep them, even if you don't want to. Take your promises seriously if you have a defined Will Center, as it takes time and energy to follow through, and you always deliver on your word.

When Defined and Undefined Will Centers Meet

The energy between the defined and undefined Will Center can create an interesting explosion of force. The defined Will Center has the Will Center to endure and the energy for value. But remember, that defined energy is fixed. People with a defined Will Center have true willpower. If they decide they're going to do something, they most likely will.

The undefined Will Center can amplify the willpower of the defined Will. This can be an empowering and enlivening energy for the undefined Will Center. But be careful if you get locked into a power struggle with this configuration. For short periods of time, the undefined Will Center can amplify the willpower of the defined Will Center. Eventually, because undefined energy is not sustainable, the defined Will Center can wear the undefined Will Center down. In a battle of wills, the defined Will Center will eventually win.

The defined Will Center is designed to work and then rest. It is very important to take time off or go on vacation periodically; if you push too hard without rest, you may end up with heart troubles or stomach problems.

If you have a defined Will Center, you will energetically empower others by making them feel as if they can do anything. And they can, as long as they are standing in your aura. For example, say you are a motivational speaker with a defined Will Center. While your students are taking your class, they are bathed in your willpower. Your students will feel inspired and committed to following through on all that they have learned from you. But most of your students will go home and never apply the new knowledge they acquired. They are out of your willpower-driven auric field and have no willpower of their own to access.

Be gentle with others who don't seem to be able to “just do it” the way you can. The truth is that most people don't have willpower and need to enter into their commitments in a different way than you.

AFFIRMATIONS FOR THE DEFINED WILL CENTER

- It is important for me to rest and recharge my willpower.
- I make promises deliberately and honor them.
- I am gentle with my expectations of others. I understand that not everyone can just do the things I can.

The Sixth Center: The Emotional Solar Plexus

“Be a screen, not a sponge.”

Emotional Solar Plexus download:
www.understandinghumandesign.com

On the body graph, the Emotional Solar Plexus is the large triangle on the far right of the chart ([figure 42](#)). The kidneys and pancreas are associated with the Emotional Solar Plexus. It is a motor center, and this emotional energy fluctuates in waves.

The Open Emotional Solar Plexus

About half of us have an open Emotional Solar Plexus. Emotionally open individuals are here to learn about emotional energy and become wise about feelings. When you are emotionally open, you are truly empathetic and can take in other people's emotional energy and amplify it.

This can be a great gift. I am emotionally open and use this attribute as a way to better understand my clients' emotional states. Many emotionally open people are great at sales because they can instantly read their client's emotional status and tailor their sales pitch accordingly.

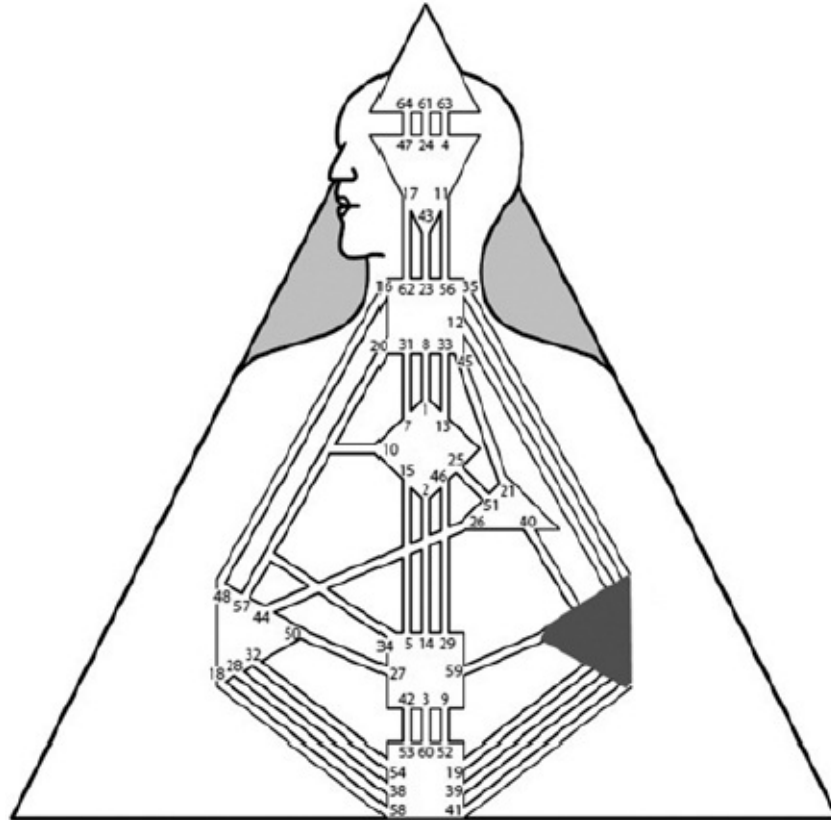

Figure 42: The Emotional Solar Plexus

Because the open Emotional Solar Plexus will take in emotional energy and amplify it, this can be a very painful center to have open when you do not understand how it works. It is easy to think that the emotions you are experiencing are your own, and if someone else's energy is negative, it can be painful when it flows into your awareness. Consequently, it is common for open emotional people to develop coping strategies that involve being nice, pleasing, avoiding conflict, and having a secret life.

It is not that emotionally open people are weak or lack character. It is truly more painful for these people to enter into highly charged emotional situations. It is crucial to become conscious of emotional energy when you are emotionally open so that you can allow that frequency of energy to flow through you without you feeling responsible for it or as if you need to fix it. Be an emotional screen, not a sponge.

Oftentimes the child who is consistently acting out with great drama is an emotionally open child. This child is picking up and amplifying the emotional energy of the whole family. On their own, however, these children are actually

quite mild and don't experience a lot of emotional energy.

QUESTION FOR THE OPEN EMOTIONAL SOLAR PLEXUS

Are you avoiding truth and conflict?

AFFIRMATIONS FOR THE OPEN EMOTIONAL SOLAR PLEXUS

- I can make decisions in the moment.
- I pay attention to the source of my emotions and allow others to experience their feelings without making their experience my own.
- I am very sensitive, and I trust my insights about other people's feelings.
- I take frequent breaks when the emotional energy is too intense.

The Defined Emotional Solar Plexus

The defined Emotional Solar Plexus will be brown. If you are part of the 50 percent of the population that has a defined Emotional Solar Plexus, you carry emotional energy at all times.

The channels connecting your Emotional Solar Plexus to other centers will determine the kind of emotional waves that you experience. Some of you have only small undulations in your emotional frequency. Others may experience high emotional highs and low emotional lows, with plateaus in between.

Because of the wavelike nature of emotional energy, it is easy to mistake the melancholy of the low end of the wave for depression. If you are emotionally defined, depression can become a big problem if you are looking for a reason why you are feeling down. We have a lot of judgment against negative emotions in our culture. But not all negative emotions are destructive. Melancholy or the low end of an emotional wave is also a very important creative energy. It allows a person to evaluate an issue from many different emotional perspectives.

If you are emotionally defined, it is a good idea to keep a log of your emotional energy on a daily basis. Each person has their own unique emotional rhythm, and knowing your emotional pattern will help you make healthy decisions and understand the timeframe that you may need in order to reach emotional clarity about an issue.

Because you experience emotion in waves, it is crucial that you honor your process. Emotional definition is always your authority, so no matter what type you are, wait until you have emotional clarity before you take action or respond. My emotionally defined clients have told me that they experience a

kind of internal “click” when they feel emotional clarity and readiness to take action. They have also said that, to a certain degree, they always feel a little nervous about their decisions even when they feel clear. Waiting for the right emotional state before taking action will keep you from leaping into emotional decisions and regretting them later.

When Defined and Undefined Emotional Solar Plexuses Meet

The emotional energy exchange between people can be flavored by the definition or openness of the Emotional Solar Plexus. When someone with a defined Emotional Solar Plexus and someone with an undefined Emotional Solar Plexus have an intense emotional interchange, the open individual may actually be the person raging or expressing other intense emotions. Remember, the open center will take in energy and amplify it.

Remember, emotionally defined people will experience emotional waves. The open emotional person will take in the emotional waves and amplify them. Both my partner and I are emotionally open. We have three children who are emotionally defined and one child who is emotionally open. One day my partner and I were in the kitchen having a pleasant chat. My emotionally defined daughter walked through the kitchen, and within seconds my partner and I were having a fight—for no reason!

As soon as I became aware of what happened, I realized that my daughter was low on her emotional wave and had simply broadcast her frequency into the kitchen, where we picked it up and amplified it. It is so nice to have awareness of this energy and just simply allow it to be without having to react to it.

It can even be more intense with two open emotional people. When an emotional spark gets going between the two of them, the energy just runs back and forth between them, constantly amplifying.

If you are emotionally open, your best strategy for handling conflict is to get out of the aura of the person with whom you are struggling. Breaking auric space will allow the emotional energy to leave your system, and you can quickly deescalate and then return to the situation in a calm way. When both parties understand this need for space and a break, it can become easier to manage the conflicts of everyday life without destroying the fabric of a relationship.

Two emotionally defined partners must also learn to honor each other and be

conscious of where their partner is on their emotional wave. If one is down and one is up, it can be an interesting combination. It is crucial that both parties realize that emotional energy is not personal, and allowing each other to experience the emotional wave without judgment is vital for this kind of relationship.

AFFIRMATIONS FOR THE DEFINED EMOTIONAL SOLAR PLEXUS

- I take my time making decisions and know that I reach clarity over time.
- I am here to be deliberate, not spontaneous.

The Seventh Center: The Root

“Under pressure to be free.”

Root Center audio download:

www.understandinghumandesign.com

The Root Center is the square located at the very bottom of the body graph ([figure 43](#)). This is the center for adrenaline. It is also considered one of two pressure centers in the system (the other one being the Head Center). The Root Center energy operates in pulses.

The Open Root Center

If the square at the bottom of your chart is white, then you have an open Root Center. It takes in adrenaline energy from others and amplifies it. Someone with an open Root Center might enjoy the rush of being in front of a crowd or other adrenaline-charged experiences, such as skydiving or bungee jumping. On a more simple level, people with open Root Centers may opt for safer adrenaline fixes, such as caffeine or chocolate.

Because the open Root Center is a pressure center, individuals with an open root can sometimes feel that they are under pressure to be free. In other words, people who process energy this way have a hard time relaxing or playing unless all their work is done. It seems reasonable to get your work done before you can go out to play, but people with an open Root Center will feel such pressure to get things done that they don't ever allow themselves time to recharge their batteries. Eventually, they can become so drained that they are ineffective at

work.

Sometimes, the energy taken in the open Root Center might be too much for a person, and they may suffer from stress, or even stage fright or a panic disorder. Individuals can have different levels of sensitivity in their open centers.

The truth of the open Root Center is that the work is never done. If you give an individual with an open Root Center a job to do, they will do it very quickly in order to get out from under the pressure of having to get it done. Of course, while they may be efficient, they can be moving so quickly that they make mistakes or skip steps—especially if they are a Manifesting Generator.

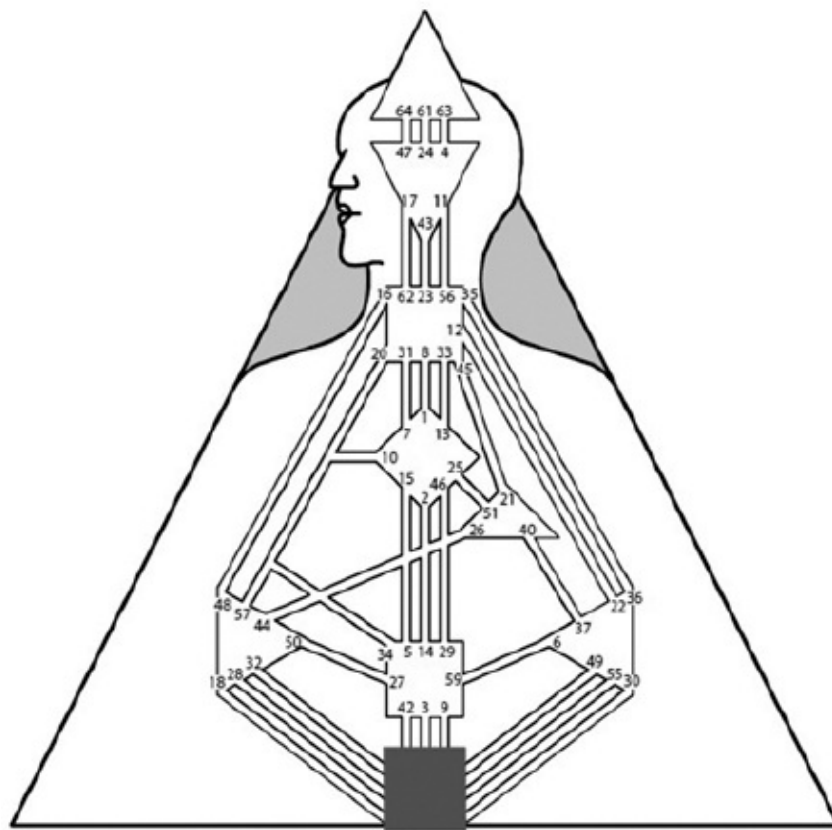

Figure 43: The Root Center

Naturally, we tend to assign these people more work because the more work you give them, the more pressure they have to get it done. And the more they do. It can be a never-ending cycle. That is why it is crucial to realize that the open Root Center is just an energy center and you do not have to be a victim to that energy. Just be free anyway.

When Defined and Undefined Root Centers Meet

Root Center energy can present interesting challenges in relationships. The thing to understand is that awareness is the key to mastering any kind of energy. When you are conscious of how Root energy operates in your relationship, it can help you not take it personally.

If you have an open Root Center and your partner, child, or boss has a defined Root Center, you will feel as if that person is putting you under pressure, even if they are simply noting that the sky is very blue today. Just being in the presence of defined Root energy will make you feel pressure. You may eventually feel that there are all kinds of expectations in your relationship that you can't live up to. With an understanding of your Root Center energy, you can realize that the pressure you feel is simply energetic, and the expectations you feel along with it may not even be real.

If you have a defined Root Center and your partner, child, or boss has an undefined Root Center, you may feel hurt that your partner feels pressured by you. Again, with simple awareness, it is possible to understand that the pressure your partner feels is energetic and not personal.

QUESTION FOR THE OPEN ROOT CENTER

Are you still trying to get things done so you can be free?

AFFIRMATIONS FOR THE OPEN ROOT CENTER

- I set realistic goals.
- I make powerful decisions about being free, and I know that things will get done when they get done.
- I use pressure to create more energy, and at the end of the day I rest and relax, even if my to-do list is long.
- I make decisions according to my Human Design strategy, even if I feel pressure.
- I breathe and relax, knowing that there is an abundance of time to get things done.

The Defined Root Center

If you have a defined Root Center, the square at the base of your chart will be

brown. This means that you have a fixed way of processing adrenaline energy, and it will operate cyclically, depending on which of the lines you have colored in around your Root Center. You will get things done when the adrenaline pulse is there; when you don't have that adrenaline pulse, things won't necessarily get done. You have a natural cycle for your adrenaline energy.

If you have a defined Root Center then you are somewhat immune to adrenaline pressure. That doesn't mean that you don't experience stress. However, your stress may come from other factors or through other open centers that you may have in your body graph. Simply put, when you have a defined Root Center, things get done when they get done.

AFFIRMATIONS FOR THE DEFINED ROOT CENTER

- I honor my root pulse and wait for the energy to get things done.
- I get more done when the energy is “on.”
- When the energy is off, I know that it is my time to rest and restore.

The Eighth Center: The Spleen

“It is healthy to be afraid and to go into a dark cave.”

Spleen Center audio download:

www.understandinghumandesign.com

The Spleen is the large triangle located on the left side of the Human Design chart ([figure 44](#)). The Spleen is the center for intuition, time, the lymph nodes, and the immune system.

The intuition that is located in the Spleen is survival based. The Spleen operates strictly in the now. When you have “gut feelings” about something, the feelings are usually short lived. This is why it is so easy to ignore your gut and go ahead and do something anyway and then regret it later! The Spleen is a “feel-good” center.

Survival-based intuition can sometimes feel like fear. The Spleen Center is kind of like the “caveman” center in that it is primal and instinctive. Certain fears can be healthy and beneficial, such as being afraid to go into a dark alley at night. When you have a lot of gates activated in your Spleen you can sometimes be prone to a lot of different fears—not all of them so beneficial. The good news is that the fears of the Spleen exist only in the moment, and

although they can feel terrifying, it is easy to push through them—particularly if they seem illogical.

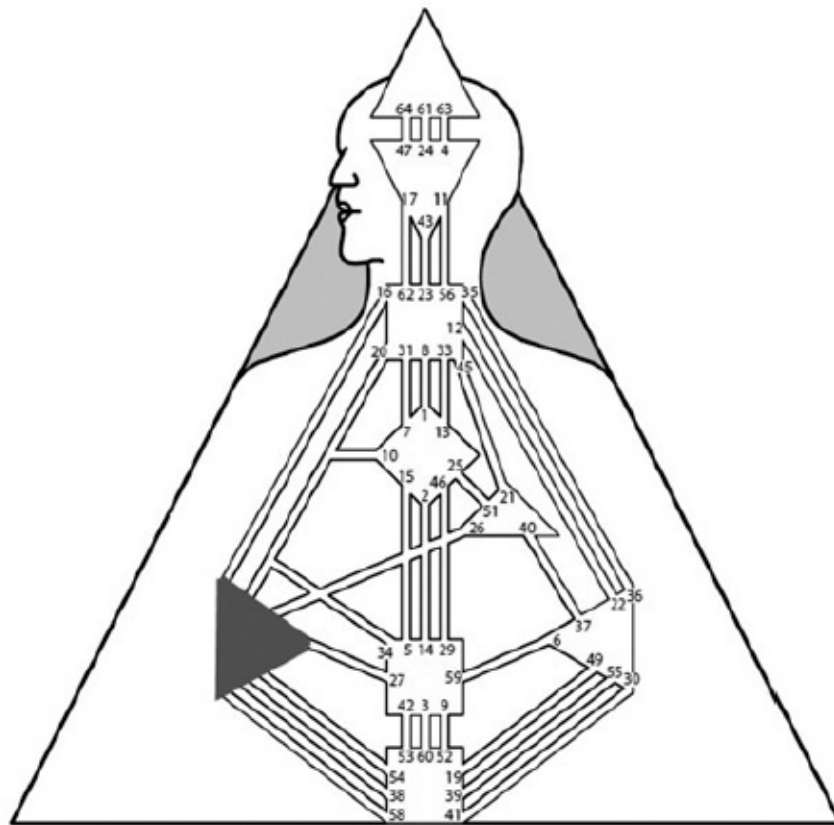

Figure 44: The Spleen Center

Remember, the Human Design system is purely about energy. Sometimes we experience these energies, and it isn't logical or even personal. Understanding your Human Design can really help liberate you from being a victim of certain energies, such as fear.

The Spleen is also the center for time. People with a defined Spleen have an easy time being in the moment. In fact, sometimes they have a hard time moving beyond the moment. The Spleen is also the center for the immune system.

The Open Spleen Center

An open Spleen means that you likely have a sensitive immune system. It may seem like you get sick easily, but what that really means is that you are very sensitive to the subtle changes in your body, and you notice when you start to

feel a little “off.” You may be very sensitive to medications and need lower doses, or you may even do better with homeopathic remedies. Also, be aware that your tolerance for alcohol or recreational drugs may be lower, and you may experience the effects at much lower rates of consumption.

When you have an open Spleen, it means that you don't have consistent access to “feel-good” energy. People with open Spleens like to be around people with defined Spleens. It makes them feel nurtured and strong.

People with open Spleens can have a hard time letting go. This can include possessions, addictions, relationships—even grudges. For example, say you have an open Spleen and you are dating someone with a defined Spleen. Being with this person makes you feel good. You feel nurtured and protected when you are with them. But this person might not treat you the way you deserve to be treated, and you may have a hard time ending the relationship because, unconsciously, your energy field likes to be in the energy of this person.

Remember that an open center is unlimited in how it can experience the energy of a particular center. If you have an open Spleen, that means that you can experience unlimited intuition. It just won't always be the same. Someone with an open Spleen may experience “gut feelings” one day, have “inner knowingness” on another day, and hear a guiding voice or have a prophetic dream on a different day. Because an open Spleen doesn't have consistent access to intuitive energy, many people with an open Spleen think they don't have very much intuitive insight.

How an open Spleen receives their intuition will vary depending on who they are around, but they will probably be deeply intuitive.

Because the Spleen is also the center for time, it is common for people with open Spleens to struggle with the concept of time. Many are chronically late, while others who have had bad experiences in the past with being late are compulsively early. This is especially important to understand if you have a child with an undefined Spleen. Always leave a little extra time when you need to get out the door quickly. It can be difficult for people with open Spleens to rush! Because our open centers are where we carry our deepest conditioning, if you have an open Spleen, you have the potential to be hyper-aware of time, particularly if you have had bad experiences with losing track of time.

Remember, openness is where we carry our wisdom. When a person with an open Spleen begins to understand Splenic energy, they become wise about healing, wise about intuition, and wise about time.

QUESTION FOR THE OPEN SPLEEN CENTER

Are you holding on to things for longer than you should?

AFFIRMATIONS FOR THE OPEN SPLEEN CENTER

- I easily let go of all things that do not serve my highest good.
- I honor my body and the messages it sends me. When I feel sick, I rest.
- I honor my sense of timing and know that whenever I arrive is just perfect!
- I respect other people's sense of time and always wear a watch.
- I trust my intuition and know that I receive intuitive insights in many different ways.

The Defined Spleen Center

The defined Spleen Center will be brown on your chart. When you have a defined Spleen, you are designed to be in the moment. Your decisions will be in the moment. Your sense of timing will be “right now.” A defined Spleen will speed you up, and give you a sense of time and consistent intuitive insights in the moment.

Defined Spleens have very powerful immune systems. Because the immune system is so strong, it is easy for a person with a defined Spleen to “miss” the first symptoms of illness. If you have a defined Spleen, you might not notice that you are sick until you are very, very sick. It is also common for people with defined Spleens to keep working through an illness. It is important to remember to check in with your body periodically if you have a defined Spleen. Or, pay attention if someone asks you if you are feeling well. Sometimes other people may notice that you are sick before you do.

The intuition of the defined Spleen speaks once and then never again. That gut feeling that you should or shouldn't be doing something is your Spleen speaking to you. Most of us with defined Spleens learn to listen to the “voice” of our Spleens sometime around age forty. It is at that point that we have spent a lifetime saying to ourselves “I knew I shouldn't have done that . . .”

Because the Spleen is survival based, it can also communicate to you with fear. Some of those fears include a fear of inadequacy, a fear of responsibility, a fear of imperfection, a fear that life is meaningless, and a fear that your dreams will never be realized. It is very easy to become paralyzed by these fears. The wonderful thing about Spleen-based fears is that no matter how frightening they feel, they can be best conquered by just pushing through them.

When Defined and Undefined Spleen Centers Meet

When Defined and Undefined Spleen Centers Meet

There are two major issues when the defined and undefined Spleen come together in relationships: timing and connection. The undefined Spleen has a fluid sense of time and timing, while the defined Spleen has a strong sense of time and can plan accordingly. The defined Spleen can often struggle with the “flowy” nature of the undefined Spleen. For the defined Spleen there is only now, now, and now.

My boyfriend has an undefined Spleen. I have a defined Spleen. (Fortunately I know this!) It is very common for my boyfriend to call me and tell me that he'll be home in twenty minutes, but before he comes home he's going to run a few errands: to the cleaners, the grocery store, the bookstore (where he has epic capacity to “lose” time), and then pick up our daughter from school.

With my defined Spleen and my inherent sense of timing, I know darn well he won't be home in twenty minutes and that I better pick up our daughter from school. It's easy to get frustrated with this, but truly, it's not personal. The undefined Spleen often really just doesn't understand timing.

The second issue with an undefined Spleen and defined Spleen involves connectivity. The Spleen is a “feel-good” center. When the Spleen is undefined, it seeks out energy to feel good, safe, and healthy. This can make them seem needy or clingy to a defined Spleen. This gets really crucial when we look at small children with undefined Spleens and separation anxiety. Children with undefined Spleens tend to have a much harder time with separation anxiety, especially if the parent has a defined Spleen. Be patient with it. It does pass, but often later than it will for children with defined Spleens.

The challenge of the defined Spleen is to figure out whether your intuition is giving you an important message about survival or whether you are simply experiencing the energy of the Spleen, and you need to push forward with understanding and insight. This is where living your strategy is so important. If you are experiencing the fears of the Spleen, use the strategy of your type to decide whether you should do something or not. Don't let the fears of the Spleen paralyze you into a state of inaction.

AFFIRMATIONS FOR THE DEFINED SPLEEN CENTER

- I trust my intuition.
- I listen to my body.

- I rest and take care of myself.
- I honor my sense of time.
- I remember that not everyone is as fast as me, and I flow with universal timing.

The Ninth Center: The Sacral

“Heigh-ho, heigh-ho, it's off to work I go . . .”

Sacral Center audio download:

www.understandinghumandesign.com

The Sacral Center is one of the most important centers in the Human Design system, and it is the most important of the four motors. The Sacral is the square located toward the bottom of the chart ([figure 45](#)). It is the energy center for work force and life force energy, and it is associated with the reproductive organs—the ovaries and the testes.

The Open Sacral Center

An undefined Sacral Center has an unlimited capacity to experience life force and work force energy. The undefined Sacral Center is here to become wise about work and sexuality.

When you have an open Sacral Center, you have the ability to take in and amplify work force and life force energies for short periods of time. This means that in short bursts, people with undefined Sacral Centers can work as hard as, or even harder than, Generators and Manifesting Generators. Because of this, a lot of people with open Sacrals think they can do more than anyone else. And for short periods of time this is actually true.

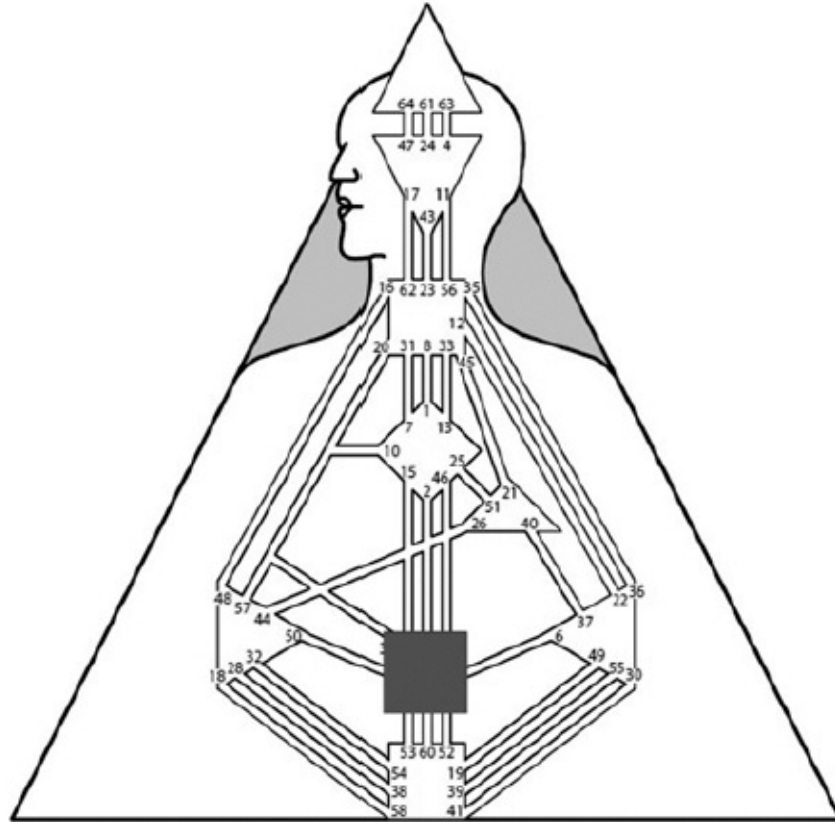

Figure 45: The Sacral Center

But remember the key word in understanding the energy of the Sacral is *sustainability*. And a person with an open Sacral Center cannot maintain a high level of energy for a prolonged period of time without really burning themselves out. What that means is that if you have an open Sacral Center, you are not here to work a Monday through Friday, nine-to-five job. And for most people with open Sacral Centers, hearing that they are not designed to work in the traditional sense is a great relief! That doesn't mean that if you have an open Sacral that you can't work or that you don't need to work. But you will probably do best finding a way to work that has some level of flexibility built into it.

Many of my Human Design clients are non-Sacral people who are around forty and have literally fried their circuits. It is not uncommon for non-Sacral beings to “crash” somewhere around forty years of age and to struggle trying to keep up with their former busy lifestyle. Because sustainability is such an important factor in a non-Sacral being, it is important for you to always ask yourself if you are doing more than enough and to help yourself recognize when enough is enough.

Collectively, we have a lot of beliefs about the value and importance of work. A non-Sacral being does not have the energy for sustainable labor. Because of this, many non-Sacral beings get a lot of judgment from others about being lazy or incapable. But non-Sacral beings have their own wisdom and energy to add to the planet. They just work differently.

Non-Sacral beings may also be judged as lazy because of their need for naps and significant alone time—but these needs are vital for their physical health. As a non-Sacral person, you need alone time to discharge the excess Sacral energy from your system. You also need to nap to recharge yourself and revitalize your body. Both alone time and adequate sleep are crucial for you to stay healthy.

Sleep can also be another important factor for people with open Sacral Centers, and it is very common for people with open Sacrals to struggle with insomnia. When you have an open Sacral, it is vital that you don't wait until you are exhausted before you go to bed. If you have waited for exhaustion, then you have probably waited too long and will struggle to fall asleep. If you have an open Sacral Center, then you must go to bed before you are sleepy. It is good for you to lie down in bed at least thirty minutes before you fall asleep. It is okay to read or watch TV, but you should be resting in a reclining position and then going to sleep.

It is also important for you to sleep alone at least a few nights a week. If you are sleeping with a Generator at night, they will wear you out. Your Sacral Center will not get a chance to discharge all that extra energy, and again, your system will suffer. Of course, this is an issue that you will want to discuss with your partner to find a win/win solution. Always remember, understanding your Human Design and taking appropriate actions to protect and nurture your energy system is part of staying strong and healthy.

QUESTION FOR THE OPEN SACRAL CENTER

Do you know when enough is enough?

AFFIRMATIONS FOR THE OPEN SACRAL CENTER

- I am not here to work in the traditional way.
- I can work hard in short bursts and then I need alone time to discharge the extra energy I carry.
- I recognize that my energy is mutable, and I take care of myself and let go of the expectations of others.

- I am very powerful when I am using my energy correctly.

The Defined Sacral Center

If you have a defined Sacral Center, it will be red. This red square is what makes you a Generator. The most important function of the Sacral Center is work. When you have a defined Sacral motor, you are designed to work. The challenge is, of course, finding the right work that you love.

Most of my coaching clients are Generators and Manifesting Generators who are feeling frustrated because they hate their jobs and feel stuck in their work situation. This is usually because they have entered into their relationship with their work incorrectly.

The energy of the Sacral Center is counterintuitive to how most of us have been raised in this culture. Generally speaking, we have been raised to believe that we have to go out and “make things happen.” We have been taught to “manifest our destiny.” But, as many of you may have already experienced, if you have a defined Sacral and you go out and try to make things happen, you usually just feel frustrated because nothing turns out the way you had planned.

If you have a defined Sacral motor you are designed to wait for things to show up. This can be very difficult, because that Sacral energy hums and buzzes and is just longing to do something. Sacral beings are very busy people. They are designed to be “doing.”

But the Sacral Center is all about waiting and the responding to whatever shows up in your outer reality. Think about this. If you have a defined Sacral Center, how many times have miraculous and unexpected things happened to you out of the blue?

And what happens to you if you go out and try to make things happen?

I am a Manifesting Generator, and I have had to work very hard to learn how to wait for things to show up. I am not the most patient of Sacral beings. I remember when I first learned about my Sacral motor and its wait and respond energy. I really wrestled with the whole idea. I had not waited for anything in my whole life! But I had to admit that my life had felt pretty frustrating up until that point.

Sacral energy works best if you learn to wait for the right thing to show up and then respond to it. Remember, though, just because it shows up doesn't mean you have to do it. You do have the freedom to choose.

Defined Sacrals are designed to wear themselves out every day. They should be experiencing exhaustion and then falling asleep. It is very important to sleep

when you are exhausted. If you are waiting for your second wind, you are running on energy that you don't really have, and eventually your health will suffer.

If you have a defined Sacral and you are having a hard time falling asleep at night, that simply means you did not get enough physical activity during the day. You may want to consider moving your body more on a regular basis. Generators need to burn out their Sacrals.

This becomes very important to think about when we are dealing with Generator children. In my family coaching practice, I deal with many children who have been diagnosed with attention deficit disorder (ADD) or attention deficit/hyperactivity disorder (ADHD). Many of these children are simply Generators who are not getting enough exercise and consequently not burning their Sacral motors out each night. As these children become more and more sleep deprived over time as a result of not being able to fall asleep at night, their serotonin levels begin to drop. The symptoms of low serotonin include irritability, lack of focus, and low self-esteem. These symptoms can mimic the symptoms of ADD or ADHD.

I often find that simply helping parents find ways to help their children get more physical exercise can dramatically improve children's ability to fall asleep and sleep well. Usually if the children can sleep well for a few weeks, the symptoms of ADD or ADHD magically go away. The same is true for adults.

The Sacral Center is also the center for sexuality. When I talk about sexuality I am talking about sex as well as reproduction. The Sacral Center is the energy for sexual encounters and raising children and making sure they make it to adulthood. When you have a defined Sacral, you have a fixed way of processing sexual energy. How you experience sexuality will usually stay the same throughout the course of your life. Sacral beings are also designed to have and raise children. The Sacral gives you sustainable energy to take care of children as well as work to provide for the children.

The real key to understanding Sacral energy is to understand that a defined Sacral Center gives a Generator access to sustainable life force and work force energy. This is very important to remember, because it is one of the key differences between a Sacral being and a non-Sacral being.

When Defined and Undefined Sacral Centers Meet

The undefined and defined Sacral face many challenges together in

relationship. It's a relationship that can work, but awareness of the differences in energy is crucial.

The keyword for Sacral energy is sustainability. The defined Sacral has sustainable energy, but the undefined Sacral does not. For short periods of time the undefined Sacral can amplify the energy of the defined Sacral, but eventually they will crash. This can be frustrating for the defined Sacral, who might not get that their partner needs more rest and downtime than they do.

The undefined Sacral needs time alone to “discharge” Sacral energy from the world. When the undefined Sacral is “overcharged,” they can feel hyper, zingy, manic. The undefined Sacral is not designed to hold on to Sacral energy indefinitely. Eventually not discharging that energy takes its toll. Undefined Sacrals need time and space to discharge energy, especially at night. To the disappointment of the Generator types, I always recommend that undefined Sacrals sleep alone in their own room, in their own aura. This is true for undefined Sacral children as well. They need their own bedroom, if possible.

The third challenge with the undefined Sacral and the defined Sacral in romantic relationships is sexuality. Remember that undefined energy has few limits in how it can be experienced, but defined energy is somewhat fixed. The undefined Sacral can have a variety of sexual experiences and even preferences. But an undefined Sacral in the aura of a defined Sacral will always be a reflection of the other person. If you have an undefined Sacral and you've had a variety of sexual experiences, your open energy is probably why. It is crucial for the undefined Sacral to enjoy the sexuality of their defined Sacral partner, because it is unlikely to change much over time.

AFFIRMATIONS FOR THE DEFINED SACRAL CENTER

- I wait with grace and patience, knowing that the right opportunities will show up for me.
- All I have to do is respond to the world, and I will joyfully do the right work and be with the right people.
- I fearlessly honor my response and know that I am internally driven to be in the right time at the right place, doing the right work.



As we continue to peel back the layers of the chart, you are gaining some profound insights into who you are and how you operate. The nine centers reveal to us so much of our life experience and give us deep awarenesses into how we experience the world, where we get stuck sometimes, and the opportunities for wisdom. When considering these sometimes not-so-subtle energies and how they play out in your life, remember that the key to living out the highest expression of all your energy is to follow your Human Design strategy according to your type.

Chapter 4

The Lines and Profiles

Your Human Design profile is another important part of understanding your Human Design and discovering who you are. Your profile is the theme of how you learn, and it illuminates how you will travel on your life path.

When we look at a Human Design chart, it is comprised of three major elements, the Incarnation Cross, the type, and the profile ([figures 46](#) and [47](#)).

Your Incarnation Cross tells you about your life path or the plotline for the story of your life. Imagine that your journey on your life path is kind of like a play or a movie. Much like the role of a butler in a movie, your type is your role in your life story. The profile represents the character or personality of your role. Going back to the movie analogy, the butler can have all kinds of different personalities, such as the grumpy butler or the curious butler or the bungling butler. The personality or character in the Human Design chart is defined in the profile.

Your profile is comprised of two numbers, which represent two kinds of energies that work together to create your experiential learning style—the gate lines in the conscious and unconscious sun. The first number is an aspect of your life role that you are conscious of and that you probably relate to easily. The second number is an aspect of your life role that is unconscious but that is also a strong part of your personality. There are twelve profiles:

| | |
|--------------|--------------|
| Design | Personality |
| 20. May 1965 | 20. Aug 1965 |
| 16:26:26 | 11:32:00 |
| GMT (0.00h) | EST (5.00h) |

24 29 ♁
 14 30 ⊕
 40 20 ☾
 35 14 ♀
 5 9 ♀
 27 4 ♀
 14 4 ♀
 4 50 ♂
 1 12 ♀
 43 4 ♀
 40 4 ♀
 1 1 ♀
 4 4 ♀
 22 22 ♀

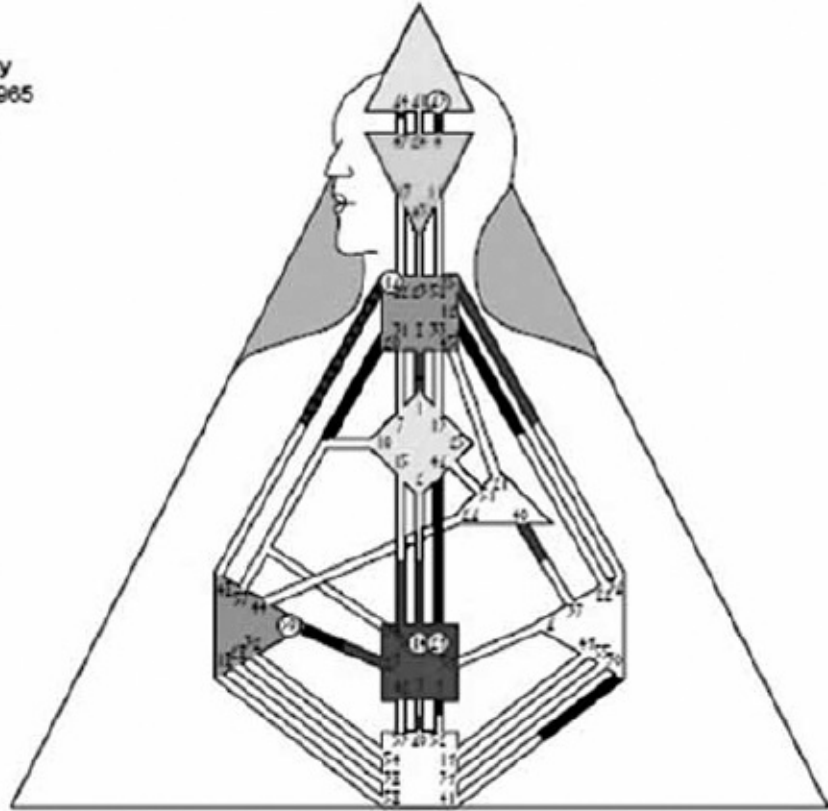

Your Individual Design Keynotes

TYPE: Manifesting Generator
 Theme: Frustration
 Strategy: Respond, envision, reprocess, reform, act

PROFILE: 4 / 6 Opportunistic Role Model
 23-30 / 8-14 : The right angle cross of Contagion (3)
 Right Angle - Personal Destiny:

DEFINITION: Split Definition

AUTHORITY: Splenic Awareness Generated

Profile

Figure 46: The profile is listed on the Keynote section.

Your Individual Design Keynotes

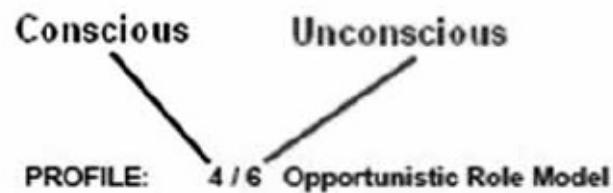

Figure 47: A profile close-up

- 1/3 - The Investigating Martyr
- 1/4 - The Investigating Opportunist
- 2/4 - The Hermit Opportunist
- 2/5 - The Hermit Heretic
- 3/5 - The Martyr Heretic
- 3/6 - The Martyr Role Model
- 4/6 - The Opportunistic Role Model
- 4/1 - The Opportunistic Investigator
- 5/1 - The Heretic Investigator
- 5/2 - The Heretic Hermit
- 6/2 - The Role Model Hermit
- 6/3 - The Role Model Martyr

The conscious and unconscious parts of your profile work together to create a unique combination of energies that dictate how you approach your life's journey. Sometimes just understanding your profile numbers can be enough to help you understand some of your core inner dilemmas, as well as reveal your ideal way to approach change, relationships, learning, and your energy and influence.

There are six possible lines that are expressed in a profile. Before you can understand the meaning of your profile, it's important to understand the meaning of each of the six lines.

Understanding the Six Lines

Just as in astrology, your energetic configuration is created at a specific time, depending on where and when you were born. Your moment of birth locks in your personality traits and your unique Human Design.

When we look at a Human Design chart, we are usually only looking at the body graph, the triangle that is the “map” of your energy. The gates and lines that create the definition on your body graph are a snapshot of the positions of the planets and gates at the moment of your birth.

For ease of interpretation, we have taken the body graph out of its full diagram. The full Human Design chart consists of the body graph inside a mandala (figure 48).

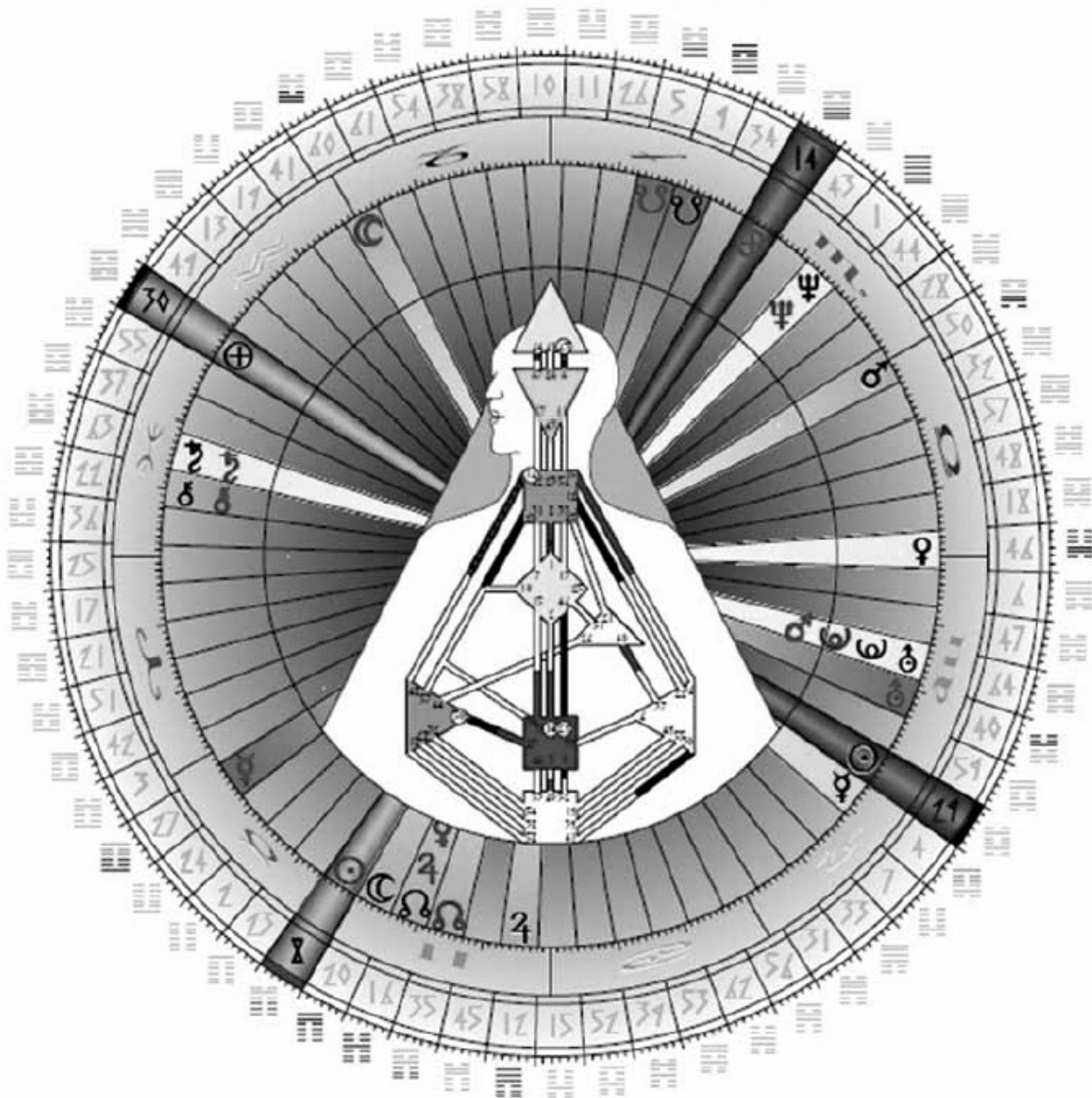

Figure 48: The Human Design body graph and mandala

As you can see, the Human Design mandala has two wheels. The inner wheel is the traditional astrological chart with the twelve houses. The outer wheel consists of a ring containing the sixty-four gates. The planetary position of your gates at your birth is measured on these two wheels.

Imagine that each of the two wheels represents a measurement of a moment in time. When you look at a clock, time is measured in minutes and seconds, and every moment has a specific place on the clock “wheel.” In astrology, the movement of time around the astrological “clock” is measured in degrees and minutes. There are thirty astrological degrees and sixty astrological minutes for each sign. Each degree and minute gives an astrologer even deeper insight into the potential of your astrology chart.

On the Human Design “clock,” the movement of time is measured in lines. Each of the sixty-four hexagrams has six lines that mark the progression of time around the mandala ([figure 49](#)).

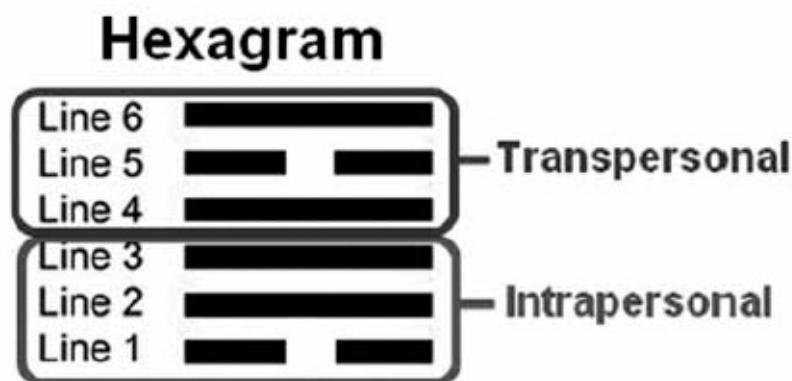

Figure 49: The I Ching hexagram is comprised of six lines that are broken into transpersonal and intrapersonal attributes.

The position of your gates is expressed also in lines, giving you even more insight into how that gate will be expressed in your life.

Each line has a specific energy that will influence how the gate is expressed.

The lines in your profile are derived from the lines of the conscious and unconscious gates in the sun position of your chart ([figure 50](#)).

Lines 1/3 in the profiles are intrapersonal lines and are energies that are self-focused and all about personal experience and understanding. Lines 4/6 in the

profiles are about transpersonal energy and all about experiences in relationships with others. Some people, by design, are focused more on their own life process, and others are more oriented toward relationships.

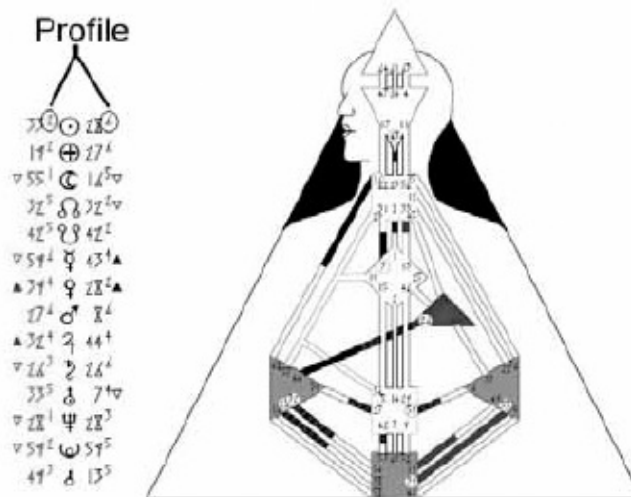

Figure 50: The profile marked on the birth chart

The six lines are:

- Investigator
- Hermit
- Martyr
- Opportunist
- Heretic
- Role Model

Some lines have similar themes, giving certain combinations of lines more inner harmony than others. Some line combinations, on the other hand, contain inherent energetic challenges.

- Lines 1 and 4 are harmonious.
- Lines 2 and 5 are harmonious.
- Lines 3 and 6 are harmonious.
- Line 1 is dissonant with Lines 5 and 6.
- Line 2 is dissonant with Lines 4 and 6.
- Line 3 is dissonant with Lines 4 and 5.

This dissonance is not about creating suffering but about helping you master your personal inner challenges so that you can grow and evolve. When you master the dissonance in your own chart, you grow in self-awareness and self-love, and you are better able to live a harmonious life.

Remember that there is no suffering in Human Design. The places where we have inherent energetic challenges are always there for a reason and are powerful catalysts for growth on our life path and for our personal evolution in this lifetime. Ultimately, when you live your type and strategy, a lot of the inner conundrums in the chart soften and become less challenging.

First we'll cover the energies of each of the six lines. Next, we'll combine those six lines to create twelve possible profiles.

The Lower Trigram: Intrapersonal Energy

Intrapersonal energy is self-focused and all about personal experience and understanding.

Line 1: The Investigator

If you are a first line profile (1/3, 1/4, 4/1, 5/1), you are very curious by nature. The first line profile needs a foundation of information to feel safe and secure about the world. The Internet was invented for you!

Before you can make a change or shift in your life, you need to investigate and learn everything about what you are about to do. If you go on vacation, you will read all the guide books beforehand so that you will be prepared for your adventure.

As a first line profile, part of your life path is to share what you know with others. Other people likely see you as a resource and a go-to person who knows a lot.

The challenge of being a first line profile is that you don't make change easily and you can feel uncomfortable if you feel as if you don't know enough. You can be overprepared for a situation, and if it doesn't go the way you planned it, can make you very nervous.

In relationships, the first line needs time to “study” their partner. You want to learn everything there is about them and relationships in general.

In its highest expression, you are deeply knowledgeable.

In its lowest expression, you are terrified of the unknown and can miss life experiences because you are too busy questioning them.

AFFIRMATIONS

- I take my time and prepare for adventures in my life.
- My knowledge is my gift to the world.
- I trust that I know enough to help me bend and flow with the changes in life.
- My confidence is rooted in my understanding of information, and I give myself permission to study until I know enough.

Line 2: The Hermit

If you are a second line profile (2/4, 2/5, 5/2, 6/2) you have a theme of shyness and loneliness in your life. If you are a hermit, you crave alone time and you usually need a lot of it to recharge yourself.

But second line energy is kind of funny. It operates counterintuitively, because the more a hermit hides away, the more it is seen by others. If you have second line energy, you experience a kind of energy vortex that draws others to you if you hide yourself too well. When you hide away, people will find you and recognize you. It is the perfect energy for Generators and Projectors.

In relationships, hermit energy tends to be shy and needs to be called out or recognized to enter the relationship correctly. This can sometimes feel frustrating, because all hermit profiles are paired with transpersonal energy that craves relationships. This can create a push/pull internal conflict for the hermit.

Of course, as a hermit, the ideal relationship is with a partner who needs as much alone time as you and doesn't take your need for solitude personally. You don't want to be away from your partner, you just need some time alone. Or you may also find that as a hermit you love having a partner who enjoys being alone with you. A quiet evening with both of you reading different books on the couch might feel like the perfect date night.

In its highest expression, you wait to be called out into the right experiences and you take time to regenerate and renew yourself.

In its lowest expression, you hide out and miss the joy of life.

AFFIRMATIONS

- My alone time is very important for me to keep my energy strong and vibrant.
- I honor my inner impulse to be alone and know that Divine Order will find me and call me out of my aloneness when the timing is correct.

Line Three: The Martyr

If you are a third line profile (1/3, 3/5, 3/6, 6/3), you learn by experimenting. You are here to share what works and what doesn't based on your own experimentation. You have never made a mistake in your life. Everything that you have tried that didn't work out was a crucial step in you mastering what does work. If you ever want to know the best way to do something, ask a third line profile. They've tried everything.

If you're a third line, your life path is experiential. You have to do something to work out all the bugs. But sometimes a third line profile will shut down out of fear of making a mistake or getting it “wrong,” especially if you've been judged or criticized for not getting it right.

It's important to understand that all of your so-called mistakes are part of your learning curve. It doesn't matter how much you know or how much you've prepared, things will go “wrong.” These “mistakes” aren't a reflection of your character. They are a vital part of your experimental process that helps you discover in a practical way what is truly useful and effective.

Around the age of forty, some of your experimentation will settle down. The experiences of your youthful exploration will give you the depth to be truly wise about life. You will always want to try everything, but by forty you'll have a deeper awareness of what needs to be experienced and what doesn't.

In relationships, you need a lot of time to get clear about what you want and need. The third line energy can often make you fall in love at first sight and think that you've found the One. Unfortunately, your third line energy can make you fall out of love as quickly as you fall in love. As a third line profile, you need a lot of space, freedom, and time in a relationship to know whether it is correct for you or not. Take it slow. It helps you avoid disappointment and keeps you from hurting others.

In its highest expression, you are wise about life based on your own experiments and experiences.

In its lowest expression, you are afraid to try new things because you know there will be a certain amount of trial and error associated with them.

AFFIRMATIONS

- I am an experimental, experiential learner. I need to try something to understand it better.
- All of my so-called mistakes have been crucial steps in cultivating my wisdom.

- I know what works and what doesn't because I've tried it all, and that makes me very wise.

The Upper Trigram: Transpersonal Energy

The upper trigram (lines 4 through 6) is about transpersonal energy and relationships with others.

Line Four: The Opportunist

If you are a fourth line profile (1/4, 4/1, 4/6), your relationships are very important to you. You probably have gotten some of your greatest opportunities in life from your social network and your friends. The fourth line energy is gregarious and deeply rooted in relationships. If you are a fourth line, you have a lifetime process of getting to the foundation of what it means to be in relationships. You care, and you care deeply.

The fourth line profile is not a profile that makes changes very easily or even readily. You like things to stay the same, and you want people to accept you as you are and never try to change you.

If you have fourth line energy, you are all about foundations. When you make a change, you move yourself from one foundation to the other; you have to be well-prepared and have your new opportunity ready before you can make a shift. That means you don't leave a job until you have another job lined up. You don't leave a lover until another relationship is available. You don't move until you know where you are going, and the unknown is very, very uncomfortable for you.

To have a great relationship, you have to have a strong foundation of friendship first. If not, you will feel insecure and nervous. There can be a certain platonic quality to your energy, which can be frustrating sometimes because your potential partners don't always realize that you are romantically interested. They think you're just good friends. But as a fourth line profile, you need to always know where you stand. It's normal for your relationships to end in friendship, too. You might have a lot of old lovers who are now dear friends.

In its highest expression, you are consistent, stable, and a good friend.

In its lowest expression, you are afraid to speak your truth and fix things. You simply create an alternative and then move on, sometimes without dealing with the challenges.

AFFIRMATIONS

- I make change slowly and deliberately. I wait for the right opportunity to reveal itself, and then I leap.
- The unknown is not good for me and rocks my foundation.
- My relationships are the foundation of my life and the source of many of my opportunities in life.

Line Five: The Heretic

If you have a heretic profile (2/5, 5/1, 5/2), your life has a more destined quality than you perhaps realize. As a heretic, you have a life path that is about helping others. But it's not just by your actions that you help others. Energetically you serve as a mirror for others to help them with healing and aligning their energy. This isn't necessarily anything you do consciously. This is simply an artifact of your energy.

This energetic mirroring makes it difficult for people to see you for who you really are. How you appear to others is a projection of their consciousness and what they need to work on to heal. Because of this, you might sometimes find yourself in the wrong place, with the wrong people, being the wrong “mirror.” This is where the heretic name comes from. Sometimes people project inaccurate expectations onto you and if you don't fulfill them, your reputation can suffer.

Of course, the converse is true: If you follow your Human Design strategy, you will find yourself in the right place, with the right people, being of service in a way that is empowering and transformative. It is so important for the heretic to follow their strategy. It can save them a lot of pain and suffering.

Because of the projections of others, as a fifth line profile you can be a master of hiding. No one really knows who you are. (They will think they do, but they don't.) It's not that you are secretive, necessarily. But you will play your cards very close to your chest.

The heretic profile in its highest expression has the capacity to influence great numbers of people and to demonstrate the highest possible energies in their chart. That means that you have seduction as a life theme. You can seduce a room with your personality, your ideas, and even your sexuality, if you choose. The fifth line makes you a great salesperson in many ways.

In relationships you like to be seductive and seduced. People are drawn to you. You can have a lot of power and control in your relationships, and you decide when to turn your charm off or on. Some heretics like the energy of seduction so much that they forget about the other parts of being in a relationship. This can give you a certain Casanova quality if you're not careful.

And, of course, because people are projecting ideas and perceptions on to you, they may perceive you as a Casanova, even when you're being faithful. The projection field of others can sometimes make relationships tricky for you. Because of your secretive nature, it can take time for you to feel safe and comfortable in a relationship. Heretics don't always like to be vulnerable or seen. When all is well, you will playfully seduce your partner again and again, slowly revealing your true self to that special someone, keeping the energy and delicious spark of your relationship alive and evolving. The heretic always seeks the highest expression of love.

In its highest expression, you can effectively influence people.

In its lowest expression, you can use your charm for personal gain and sometimes hurt others.

AFFIRMATIONS

- I have a tremendous amount of power to influence and seduce others into new ideas and inspirations. I use this influence for the greater good.
- I follow my strategy and remember that when I enter into relationships correctly, I am a tremendous force of change.
- I realize that others don't always see me for who I am, so I am deliberate, repetitive, and clear with my communication.

Line Six: The Role Model

As a sixth line profile (3/6, 4/6, 6/2, 6/3), you have three distinct life phases. Ultimately, your life path leads you to becoming a role model for others. The six line profile may be a late bloomer, but each step of your journey is crucial for the role you will serve later in life.

The first phase is from birth until the age of 28.6 years. During this first stage, your life is all about experiences and experimentation. You act very similarly to a third line profile.

The second phase goes from 28.6 years until approximately fifty years of age. Most people don't really feel this phase until they are about thirty-five years old. During this second phase, you may notice that life isn't as "edgy" and sharp as it was in your twenties. You may feel that it takes a lot of energy and effort to do things like you used to. Answering the phone and emails, and making small talk and light-hearted banter may not interest you as much. You are more interested in studying, or even just resting. Part of the purpose of this phase is to help you heal from the first part of your life and to watch other

people to see what they are doing and how they are mastering life. This second phase is often referred to as “being on the roof.”

When you're on the roof, it's a great time to build a business or focus on yourself. Because so much of this phase is about inner work, it can often be a hard time to initiate any kind of relationship. Even parenting can be difficult during this time, especially if you don't understand what's happening to you. Sometimes when sixth line profiles go through this phase, they think they're depressed.

The final phase starts around the age of fifty and lasts for the rest of your life. When you “come off the roof,” it can sometimes be a cataclysmic descent. The themes of the first part of your life can come back with newfound wisdom and maturity. It's not unusual for you to experience dramatic life changes during this time as you move toward creating a life that is a full manifestation of your authentic self.

The final phase, called the role model phase, is a time when you have tried everything, figured out what works, and are now living true to yourself. As a role model, there isn't much you need to do except be yourself. Others are watching you now to see how to make the best of their lives.

The sixth line has somewhat of a destiny or fixed fate. As a sixth line profile, you usually are pretty clear about your life purpose and can feel it pushing on you to manifest it. If, for some reason, you're still unclear or out of sync with your destiny, your outer reality will push on you pretty hard to get your attention. It can feel very uncomfortable, as a sixth line profile, to be unclear of your life direction.

In relationships, you need and deeply desire a soul mate. This can be a long and desperate journey for the sixth line profile, especially if you are still looking for a soul while you are on the roof, when it is hard to initiate relationships. You may have to kiss a few frogs, but your search will be worth it in the end, and you'll forget how long it took when you finally find yourself in the arms of your beloved.

In its highest expression, you are a role model who inspires others.

In its lowest expression, you get stuck in your aloofness and struggle to get out into the world.

AFFIRMATIONS

- I trust in the trajectory of my life, and I understand that every step of my life's journey is leading me to my destiny.

- I relax and allow the process to unfold and honor myself for who I am.
- I know that being me is the most important thing I can do, and I courageously commit to an authentic life.

The Twelve Profiles

The six lines can combine the conscious and unconscious to create twelve different profiles:

- 1/3 Investigator/Martyr
- 1/4 Investigator/Opportunist
- 2/4 Hermit/Opportunist
- 2/5 Hermit/Heretic
- 3/5 Martyr/Heretic
- 3/6 Martyr/Role Model
- 4/6 Opportunist/Role Model
- 4/1 Opportunist/Investigator
- 5/1 Heretic/Investigator
- 5/2 Heretic/Hermit
- 6/2 Role Model/Hermit
- 6/3 Role Model/Martyr

The first number in your profile will always be the conscious energy; the energy that you follow first and that you are more aware of. The second line in your profile will be the unconscious energy; it is more subtle and follows the energy of the first number. *The conscious energy always precedes the unconscious in the profiles.*

For example, if you are a 1/3 profile (Investigative Martyr), you have a life pattern of needing to investigate things and then experiment with them to see if they work. The first number is the conscious line of the profile and is the investigative energy. The second number is the unconscious line of the profile and is the experimental part of the profile. The 1/3 has to investigate first and then experiment, and always in that order.

While we won't cover each of the twelve profiles in detail here, I think you can figure out your profile on your own by reading about the relevant lines that make up your profile. You can also check out a two-hour bonus audio with in-depth descriptions of each profile on my website, www.understandinghumandesign.com.



Understanding your definition and openness gives you a tremendous amount of information about how you operate, what energetic experiences might be keeping you stuck, and what relationship dynamics you have been taking personally. Knowing which energies are consistent and which have variety also gives you clues about who you are, what you are here to do, and where you can grow in your wisdom about others.

Your profile gives you another layer of awareness and understanding about your life and life experiences. Now you understand your energy, your learning style, and even a bit about your life purpose and role.

Remember that in spite of the fact that you are gaining more depth and self-awareness from your Human Design chart, the way to maximize the expression of your true self is very simple. Follow your Human Design strategy according to your type, and the magic of life unfolds easily.

Part Three

Gates, Circuits, and Channels

Like all the energies in the Human Design chart, you can experience the high or low expression of the circuitry in your chart. The purpose of the exercises in this part of the book is to help you discover the defined themes of your channels and gates and to support you in consciously expressing the highest possible potential of your unique energy.

Remember, you have all the parts of the chart. There are no energies in the chart that you don't have. It's just that you will experience your definition more consistently than your openness.

Many of my students have found it very helpful to go through this section of the book and do the exercises for your defined gates and channels first, then go back and do the exercises for the energies that you have open in your chart.

Chapter 5

The Gates

There are sixty-four gates in the Human Design system. Gates represent specific energetic themes that give you further insight into your personality, what drives you, your life purpose, themes in your relationships, what fulfills you creatively, and even how your intuition works and how you connect to Source.

There are two gates for each channel. The position of the planets at the moment of your birth determine which gates are defined in your chart. Your defined gates are energies that you experience consistently. When both gates are defined, it defines the whole channel, as well as definition in the centers at each end of the channel. Even though you will have your unique gates defined in your chart, we all have all of the gates in some form or another. Your open gates will be experienced in multiple ways depending on who you're with and where you are.

Like all the energies in the chart, there is a high and a low expression of each gate. As you go through the gates in your chart, ask yourself how that energy may be influencing your life. We are designed to be joyful, connected, creative, abundant, and powerful. When you live out the highest expression of the energies in your chart, the magic of life unfolds naturally for you.

In this section, each gate is followed by an affirmation and a series of written exercises designed to help you discover the high expression of the energy of each gate in your own life. I suggest that you first explore your defined gates and then revisit this section to look at how your undefined gates may have been influencing your life.

Remember that the key to expression the highest possibility for your life is not only becoming self-aware, but also living your Human Design strategy.

Gate 1: Self-Expression

I Ching: The Creative
Astrology: Scorpio
Biology: Liver

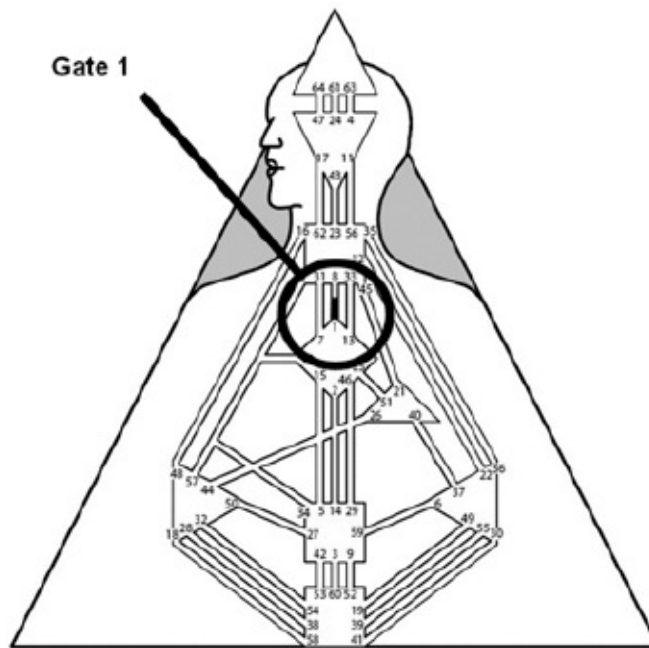

Figure 51: Gate 1

Gate 1 is the most yang of the hexagrams (yang-yang). This is a powerful energy that pushes on a person's spirit if they don't fulfill their need to express themselves creatively. This energy will wake you up at night with the thought that there is something you are supposed to be doing with your life, and if you don't know what that is, you can become very anxious.

Gate 1 by itself is always seeking more energy to get this expression to the Throat. It may have to get it from others in collaboration, but it will not feel comfortable or fulfilled unless it finds a way to express itself. People with this energy want to do more than volunteer for a blood drive; they want to change the world. And they have the motivation to do it, provided they use this energy correctly.

There is a tremendous amount of knowing in this channel. There is a knowing about the right contribution at the right time. Someone with Gate 1 may have to wait for recognition and the right energy to move the contribution of their soul out into the world. Waiting is hard, but it is crucial to have the correct impact.

Affirmations

- Every day is a new creation.
- My greatest contribution to the planet is to be the fullest expression of myself as myself.
- The fulfillment of my divine potential is important for the evolution of humanity.
- I trust the process and release any fears that I may have about “failing my life mission.”
- I am on task and in the right place, making the right contribution.

Writing Assignments

1. Are there times when you hold yourself back from fully expressing yourself? What would it take for you to step into your fullest expression?
2. What does the word “legacy” mean to you? Are you leaving an authentic legacy? Are there limiting beliefs and experiences preventing you from expressing your authenticity? What do you need to do to release them?

Gate 2: Keeper of Keys

I Ching: The Receptive
Astrology: Taurus
Biology: Liver

Gate 2 is the energy for managing wealth. It is the most yin of the hexagrams (yin-yin).

Gate 2 is not necessarily the energy for making money, but it likes money and the comfort of knowing that the financial foundation is secure and supported consistently. Gate 2 takes in the resources created by Gate 14 and allocates them in order to facilitate the expression of power.

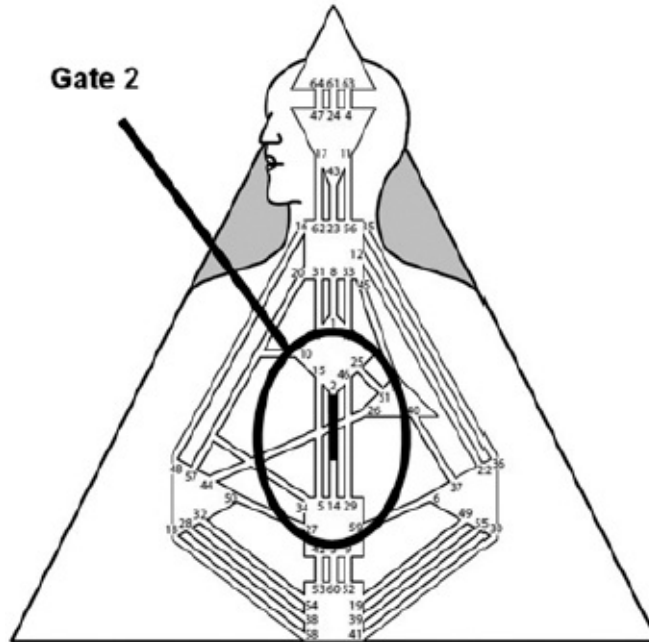

Figure 52: Gate 2

Of course, this gate can have a youthful expression that can lead it into reckless spending without the awareness or willingness of what is necessary to generate wealth. The metaphor of a teenage girl at the mall with her daddy's credit card fits well here. But ultimately, the highest expression of this energy is about having and managing resources well, so that you have what you need to make a transformative expression and contribution in the world. Gate 2 manages resources so that wealth is available to create influence and to get things done in a transformative way.

Affirmation

I am wise about resources and understand what is necessary to build a strong foundation of support for my destiny and my contribution to the world.

Writing Assignments

1. What steps do you need to take to surrender to your destiny?
What resources are necessary?
2. What resources do you have already? What do you need to do to create a solid foundation of support for the fulfillment of your dreams?

Gate 3: Ordering

I Ching: Difficulty at the Beginning

Astrology: Aries/Taurus

Biology: Ovaries and testes

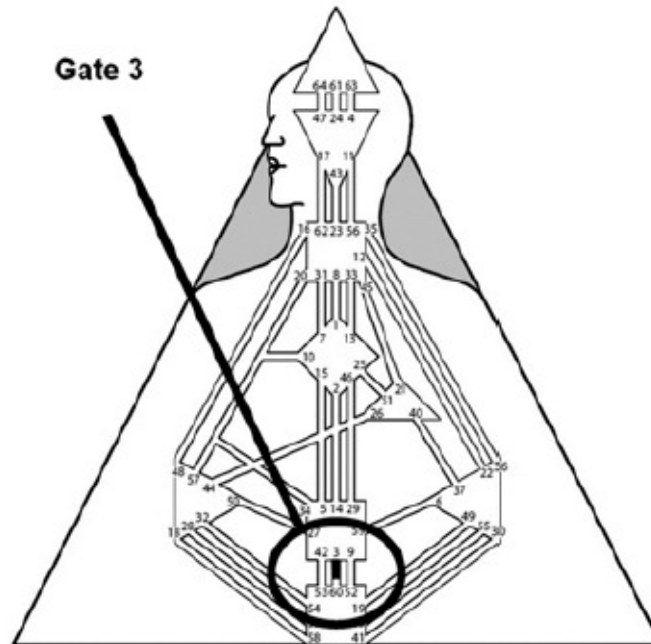

Figure 53: Gate 3

Gate 3 is about mutation and transformation. On a genetic level, Gate 3 brings new genetic material that pushes up against old genetic material to see if it can be integrated. On a work level, it seeks to mutate the work experience and response. Gate 3 responds to work that brings change that, without limitation, can often be maladaptive or just plain strange. The purpose of Gate 3 is to respond to work that is vital to transforming or creating change in the world. Gate 3, like all mutation, has difficulty in the beginning. It has to have this in order to “prove” that the energy is worth integrating. Without the struggle, society is at risk for reckless and capricious change.

People who have this energy defined in their charts can sometimes feel that things are harder for them in the beginning. Perseverance will ultimately show them whether their difficulty was worthwhile or not.

Affirmations

- I accept and embrace limitation and love what is.
- I trust that what I am experiencing in this moment will perfectly support me in creating what I intend.

Writing Assignments

1. Are there areas of your life where you feel as though you are getting some resistance or “butting your head against a wall”? What do you need to accept to release these resistances?
2. Do you want to do something but sense that perhaps the timing isn't right? Do you need to keep pushing, or is it time to let go and trust in divine timing?

Gate 4: Answers

I Ching: Youthful Folly

Astrology: Leo

Biology: Anterior and posterior pituitary glands

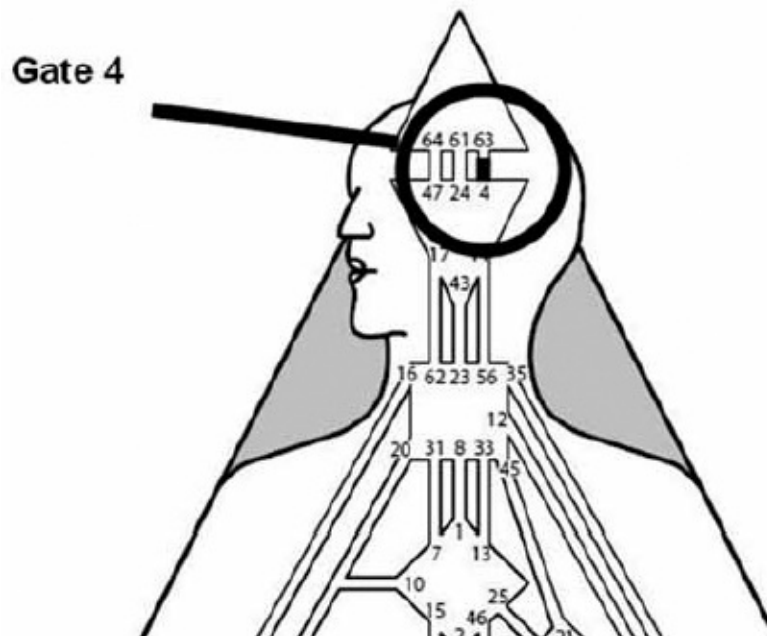

Figure 54: Gate 4

Gate 4 is the gate of the answer. The answer to what, you may wonder. It doesn't matter. It's just the answer. Answers come from Gate 4 without a lot of regard for validity. They are merely possibilities that need to be proven over time.

People with this energy, especially with an open head, will be under pressure to come up with answers. Answers can sometimes just “plop” out of this person's mouth. Remember that answering is simply an energy; just because someone has an answer doesn't make it the right one.

Affirmations

- The culmination of my thoughts and experiences grant me knowledge about how I need to proceed confidently and faithfully into the future.
- I patiently wait to see if my answers are correct.

Writing Assignments

1. What new awarenesses, knowledge, and insights do you have as a result of your thoughts, experiences, and meditations?
2. What are the next steps you need to take in your creative processes?

Gate 5: Patterns

I Ching: Waiting

Astrology: Sagittarius

Biology: Ovaries and testes

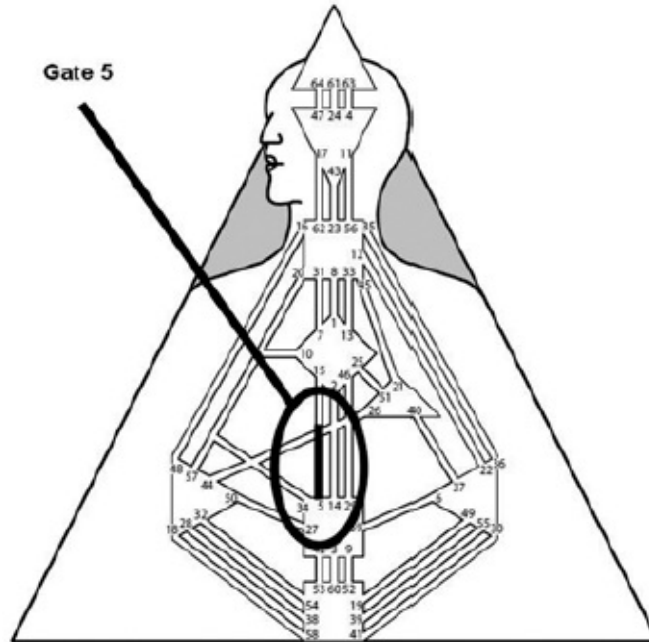

Figure 55: Gate 5

Gate 5 is deeply rhythmic. When you have this energy, it is vital that you maintain a routine in order to feel effective and good. You may find that if your routine gets interrupted, you have a hard time getting your day going.

If you are a Generator with this gate, you will respond to opportunities for work and sex that are rhythmic. Gate 5 likes routine, even intimacy and work that has a pattern, consistency, and rhythm.

Affirmations

- My routines and habits are necessary to help me direct my life force.
- I give myself time and room for my daily rhythm, and I honor myself enough to honor my special rituals. They keep me grounded and connected to Source.

Writing Assignments

1. Do you have a daily rhythm? What do you need to do each day to honor yourself, Source, and the world around you?
2. Are you getting enough time outside? What do you need to do to reconnect with the natural world?

Gate 6: Friction

I Ching: Conflict
Astrology: Virgo
Biology: Kidneys and pancreas

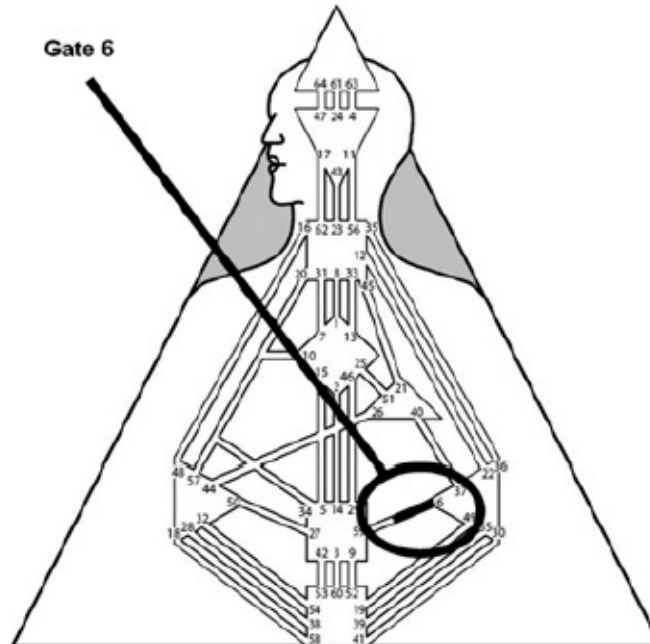

Figure 56: Gate 6

Gate 6 connects the Sacral to the Emotional Solar Plexus. It is a penetrating energy, meaning that it can break into people's auras. It is emotional and energetic, not seductive.

Sexually, this is the energy that “locks on to” another person's aura and, if used properly, can be a gateway to true intimacy. In Human Design, true intimacy comes not only from sex but also from reproduction.

The sexuality of the sixth gate is emotional. It needs clarity over time. “Evaluate and then penetrate” could be the mantra for this gate. Wait to make sure it is the right thing.

Intimacy that is waited for has the possibility of being nurturing, even though nurturing isn't inherent in this energy. When you don't wait, the relationship will not feel nurturing and ultimately will come apart. The result of the collapse

of this incorrect intimacy can be war or conflict, a lot of emotions in reaction to a bad choice.

The energy of war and conflict in this gate can also be defensive. Conflict that is being instigated as a result of time and clarity (waiting the emotional wave) can be in defense of loved ones. The Tribal Circuit (see [chapter 6](#)) requires that you energetically give up your life for the greater good of the whole. You fight for love and resources. Gate 6, with clarity, will be the first one to throw a spear to protect the tribe.

Of course, clarity is crucial here. Without clarity, war can be destructive and ultimately kill the tribe.

Affirmations

- I surrender myself to life.
- I surrender myself to my destiny and all that it means to be myself and me.

Writing Assignment

Are your desires in alignment with the truth of who you are? Are you living authentically, boldly, as yourself? Where might you need to make changes?

Gate 7: Self in Interaction

I Ching: The Army
Astrology: Leo
Biology: Liver

Gate 7 is here to serve a leadership that is bigger than itself. Because it is designed to support the leadership, the low expression of Gate 7 often struggles to try to take leadership, but usually without much success.

These are energies that have to be recognized and are, by nature, truly democratic in their highest expression. You cannot force leadership with this energy. It won't last.

People with either Gate 7 or Gate 31 are recognized as natural leaders. It is quite common for them to be put into leadership roles by a group. That is where they are supposed to be.

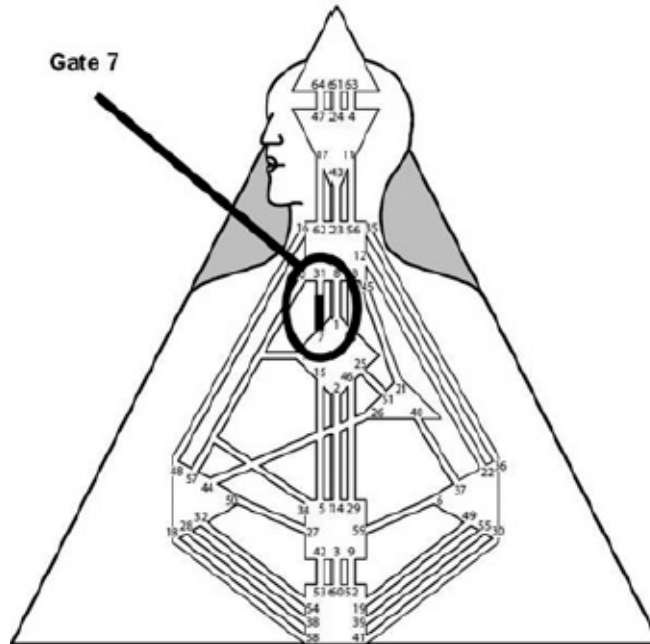

Figure 57: Gate 7

Affirmations

- I take leadership in my life and know that I will be called on to share my influence with the world.
- I am empowered, and I trust the geometry of the Universe to take me to exactly where I need to go to impress my authentic expression on the world.

Writing Assignments

1. Where do you need to take action and leadership in your life? What do you need to do to lead your dream?
2. What kind of influence and recognition would you like to be experiencing in your life? What has kept you from recognition in the past? Is there anything you need to change to increase your light?

Gate 8: Contribution

I Ching: Holding Together
 Astrology: Taurus/Gemini
 Biology: Thyroid and parathyroid

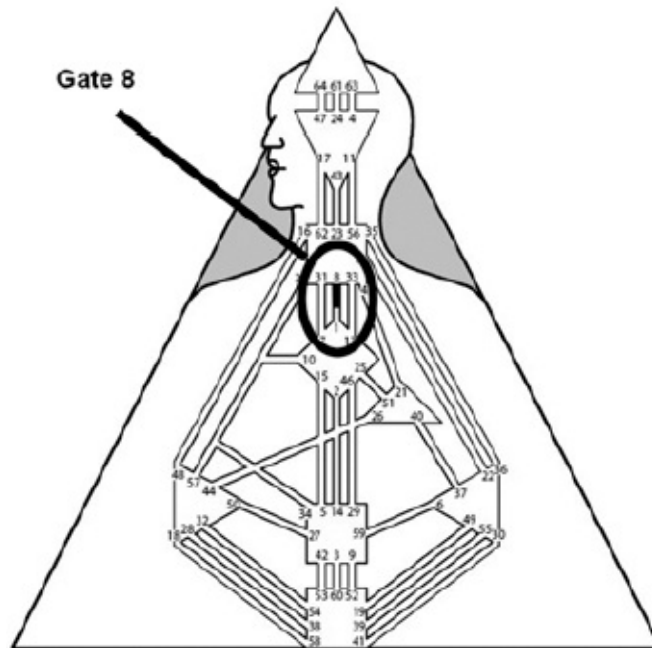

Figure 58: Gate 8

Gate 8 lacks some of the pressure of Gate 1, but it still feels the need to make a contribution. This is the final expression of individuality to the Throat Center that comes from the Sacral.

Gate 8 wants to get things done, make a difference, create change, but it can't unless it hooks with the correct energies and it gets recognition. The key here is correct timing and the right energies. Sometimes, that means waiting, which can be especially hard when there is a world to change.

In its fulfilled expression, Gate 8 is the creative role model. It waits for correct timing and then shares by “walking its talk.” Gate 8 operating correctly is inspiring and creates change by leading by example.

Affirmations

- The greatest contribution I can make is to share my light, my love, my self with the world. I commit to making my contribution by expressing my authenticity to its fullest extent.
- I never hold back. I radiate. I am a crucial part of the light of the wholeness of mankind.

Writing Assignments

1. If you could live an uncompromising life, what would it look like?
2. What do you need to do to bring this life forth? Is there anything stopping you?

Gate 9: Focus

I Ching: The Taming Power of the Small

Astrology: Sagittarius

Biology: Ovaries and testes

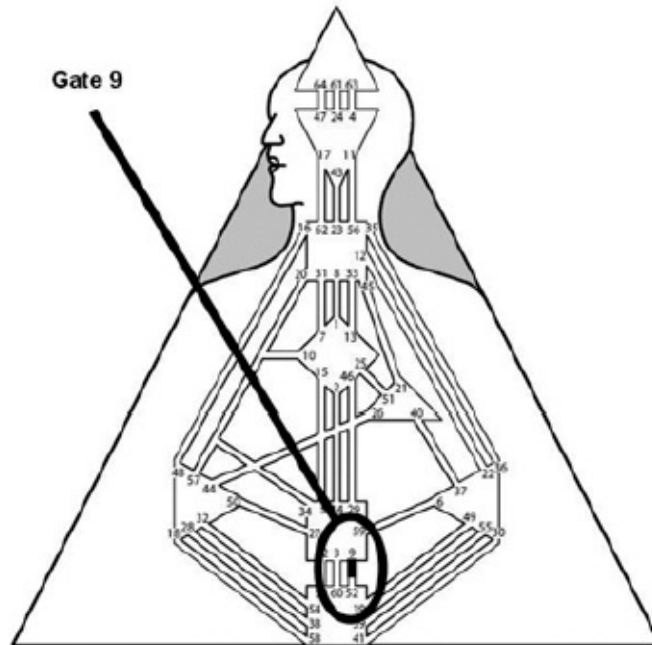

Figure 59: Gate 9

Gate 9 is the energy for focus. Whenever you see this in a chart, you know there is always the capacity for obsessive behavior and thinking. To a certain degree, Gate 9 will amp up all the energies of a chart, especially if the energy makes it to the Throat Center and isn't split off.

Gate 9 has the ability to focus, but not necessarily for long periods of time. This gate is a crucial player in ADD-like behavior, where you are focused but

also constantly moving.

If you have this energy, you may often seem obsessive to others, as if you can't let an idea go. With Gate 9, it's true. You can't let it go. You can think about it no matter what you're doing. You just might not be able to stop and concentrate on it unless you find someone with Gate 52. Both gates are crucial for learning and taking logic into collective behavioral patterns.

Affirmations

- I am always concentrating on my intentions, even if I'm busy doing other things.
- I follow my strategy and take actions that are in alignment with my concentration.
- I know that my inner concentration will manifest in my outer world.

Writing Assignment

Doing this exercise will help you discover what concrete steps you can take to make your dreams become reality.

1. Take a sheet of paper and draw a line down the middle. Title the left column "Me." Title the right column "The Universe."
2. In the left column make a list of all the things you need to do to make your dream come true. These are the practical things you need to take care of, such as writing a book, test driving a car, building a website, taking a class, *etc.*
3. In the right column make a list of all the things the Universe can do. These are the things that may feel beyond your control at the moment, such as attracting the perfect clients, friends, or lover; providing the perfect information and support; *etc.*

Gate 10: Love of Self

I Ching: Treading
Astrology: Sagittarius/Capricorn
Biology: Liver

Gate 10 is one of the most significant gates. It is rooted in the Identity Center

and associated with empowerment. The energy of empowerment in this gate is lived out by example: someone with this gate empowers others to live out their magnificence by demonstrating their own magnificence.

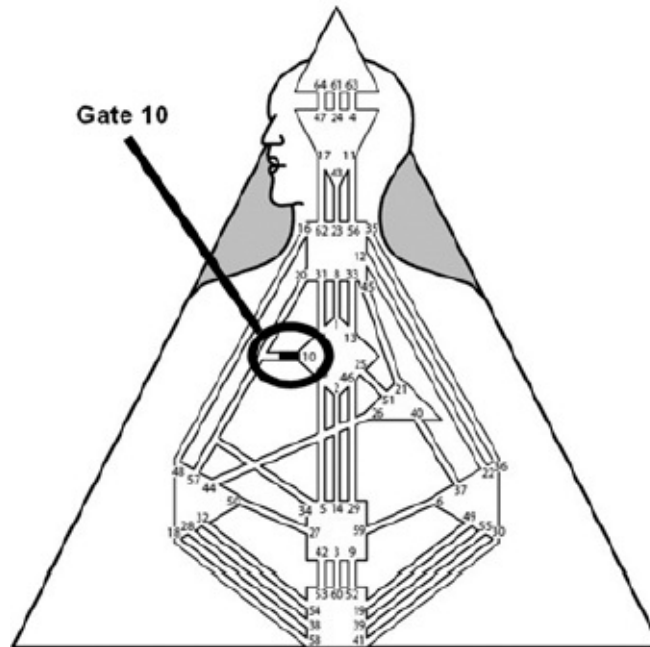

Figure 60: Gate 10

Gate 10 can be a difficult energy. In its highest expression, this is a gate of taking personal responsibility and acting in an empowered way. In its low expression, it is the energy for blaming others and taking a victim stance.

As this energy can be amplified by those who do not have it, the theme of blame can be prevalent in the life of the person carrying the energy of Gate 10. People with Gate 10 get blamed or blame others when they live out of their conditioning.

It is vital to see where Gate 10 connects:

- With Gate 57, we have perfected form and intuitive survival.
- With Gate 34, we have the Centering Circuit, which is again associated with the perfected form of survival and direction.
- With Gate 20, Gate 10 has the capacity to communicate empowerment.

Affirmations

- I honor that miracle that I am. I am a unique, divine creation, and I know there is no one like me in this world.
- I make choices and take actions that are honoring of my divine magnificence, and I surround myself with people who support me, nurture me, inspire me, and lift me up.
- I am powerful and in charge of my life direction.
- I make choices that allow me to fulfill my divine potential, and in being the fullest expression of myself, I create the space for others to do the same.
- I know that my self-love helps me align with my life path.

Writing Assignments

1. What old energies and “victim stories” do you need to release?
2. What does being powerful mean to you? What can you do to be more empowered?
3. Make a list of all the things you love about yourself. Write yourself a beautiful love letter and read it aloud in the mirror.
3. What choices and directions could you take that would be in alignment with your self-love?

Gate 11: Ideas

I Ching: Peace

Astrology: Sagittarius

Biology: Anterior and posterior pituitary glands

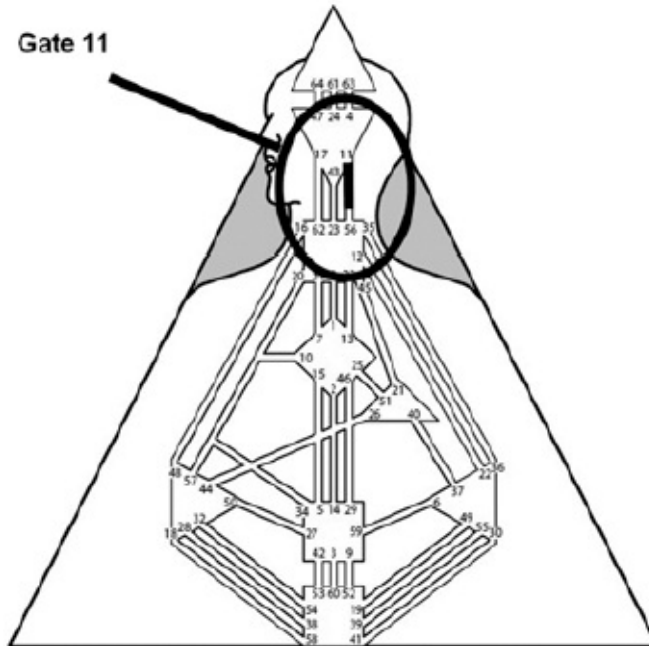

Figure 61: Gate 11

If you imagine that creativity is a stream, most of us go down to it with a cup and drink from it. People with Gate 11 go down to the Stream of Creativity with twenty washbasins and stand on the banks wondering what to do with all their ideas.

Gate 11 is filled with more ideas than one will ever be able to bring into form in a lifetime. The frustration of Gate 11 is the desire to implement one's ideas. People with Gate 11 will often complain that others “stole” their ideas or that they got “scooped.”

People with Gate 11 will make peace with their ideas if they realize that all of their ideas are not for them but to share with others . . . *when asked*. The challenge of this gate is to sit and wait for the right person to ask for their ideas.

Gate 11 is also the gate of the seeker, not the finder. When people with Gate 11 make peace with always being on a quest and never having a certain answer, they can enjoy the journey. Remember, Gate 11 is the gate of ideas. You don't have to manifest all of them—or any of them. If an idea is correct for you, it will show up in your life according to your personal Human Design strategy.

Affirmations

- I honor my inner creative process.

- I am grateful for every lesson and adventure I have in life, and I know that each story of my life experience adds beautiful, rich threads to the tapestry of my life story and the story of humanity.
- I relax and enjoy the quest for truth in my life, knowing that the more I learn, the more I grow, and the learning and growing never stop.
- I allow myself to savor every moment and serve as the creative vessel I am. I relax, breathe, trust, and let the ideas flow!

Writing Assignments

1. Evaluate your achievements and accomplishments of the last few weeks. What have you learned? How can you improve upon what you've already done?
2. Keep a running list of ideas this week. You never know when you might find the right person to share them with or when you may hit upon the million-dollar idea for your life!

Gate 12: Caution

I Ching: Standstill

Astrology: Gemini

Biology: Thyroid and parathyroid

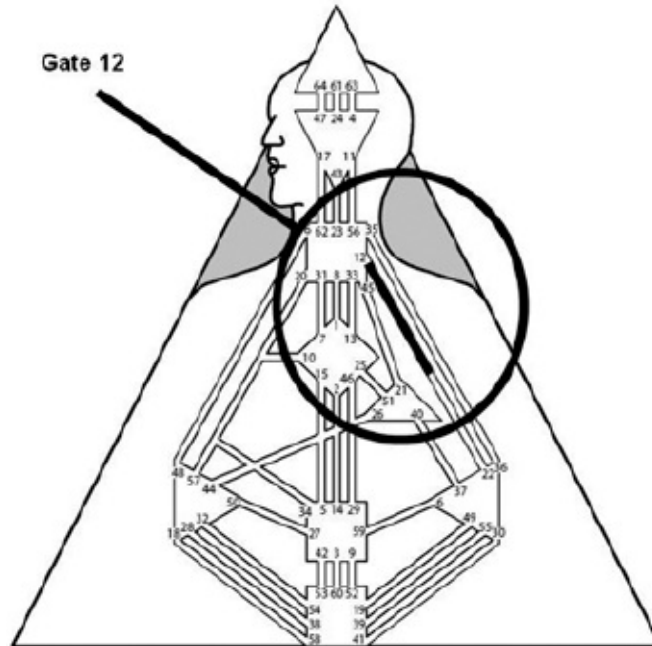

Figure 62: Gate 12

Gate 12 is cautious because it needs to know whether it is being honored or not. The root expression of this caution is shyness if the mood is not right and boldness if it is. Gate 12 is also a powerful energy that plugs into Source, and people with this energy, especially if it is defined on an open Throat Center, have a tendency to channel or prophesize.

There is a certain frustration and anger here if Gate 12 shares and the timing is not right. Sometimes Gate 12 can retreat into an “I told you so” kind of energy when their insights are proven correct in hindsight.

The irony of manifested energy is very strong in this gate. There is an impetus to speak or act, but if someone has been conditioned to act no matter what, they may have the experience of speaking boldly and creating anger around them. This can be a real inner struggle for people with this energy, often creating a “standstill” in their lives. People with this energy can become paralyzed by inertia from the trauma of having expressed themselves when the timing hasn't been right.

When the timing is correct, Gate 12 is the ultimate wordsmith. Here we have the energized creative expression of the Knowing Circuit (see [chapter 7](#)). It can be passionate, rich, and deep in its expression, with all of the juice and fire that art and creativity can bring humanity. It can be new, transformational, and very, very influential.

Affirmations

- My words, my expression, and my creation are divinely guided, and I speak the perfect words to transmit the beauty of who I am and what I create.
- My voice is heard and valued, and I continue to share my insights and my experiences as part of my creative process.
- My divine perspective supports me in evolving my ideas and creations.

Writing Assignments

1. Are you using willpower or divine power to create?
2. Do you feel stuck or at a standstill? If so, what do you need to do to keep moving forward?
3. Is it time to continue sharing your thoughts, ideas, and divine inspirations with others?
4. What playful things can you do to inspire your creative energy?

Gate 13: The Listener

I Ching: The Fellowship of Man
Astrology: Aquarius
Biology: Liver

Gate 13 is kind of magical. It's an energy that creates a very interesting response in the people around it. Gate 13 compels others to share their secrets with them. If a person has this energy, people will tell them anything and everything—even people they don't know. This is the energy of the listener.

When you have this energy, you are a storyteller, but most importantly a story “keeper.” Because this energy is so close to the Throat Center and is part of an expressive channel, it is easy to blurt out other people's stories and secrets, especially if the Throat is undefined. But keeping stories is a sacred job, and one that ultimately holds the key to part of the story of humanity.

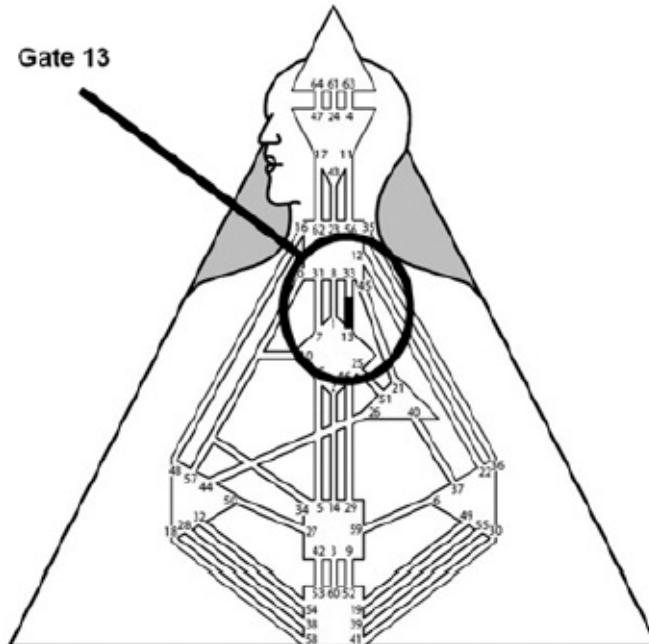

Figure 63: Gate 13

With Gate 13 comes not only the energy for listening, but also the energy for giving direction once the story has been shared. This is a very special energy, one that requires compassion and wisdom. It's good to be aware of the fact that others will perceive people with Gate 13 to be a good listener and accept that this energy is part of their life path.

Affirmations

- I am a servant to the Divine. In my quiet retreat, I align with my higher purpose, and I take actions that are of service to the greater good. Each day I ask that my mind, my eyes, my words, my heart, my hands, my body, my light, and my being be used in divine service.
- I listen carefully to the words and true meanings of others. I allow myself to see the truth behind all words so that I always know the divine meaning of each communication.
- I hold a sacred space for humanity to come together to fulfill its highest purpose.
- I lead with love.

Writing Assignments

wealth.

There can be a certain amount of luck associated with this gate. When people with this energy respond, the response is about creating wealth in some way. Being born with this energy can be like having a natural “inheritance,” and because making money can sometimes be so easy for people with this gate, they often don't care about the physical trappings of wealth.

This energy flows into a desire to make a contribution to humanity. People with Gate 14 understand that nothing gets done on the planet without finances. But it's not personal finance, like we see in the Ego Circuit (see [chapter 8](#)). This is merely about working for the right thing, to give it energy to ultimately be expressed.

Affirmations

- I trust and know that as long as I am following my strategy, I am fully supported in all my endeavors.
- My unlimited capacity to create gives me support, and I use my support to fulfill my life purpose.

Writing Assignments

1. Make a list of everything you are doing right now that you find inspiring and delicious. Make a commitment to yourself to follow at least one of these inspirations each day.
2. What would your life look like if you only followed your passion? What would you be doing? What would your life feel like? What would your energy level be?
3. Do you trust the Universe to support you in following your bliss? Can you make money doing what you love and know that you will be supported?

Gate 15: Extremes

I Ching: Modesty
Astrology: Gemini
Biology: Liver

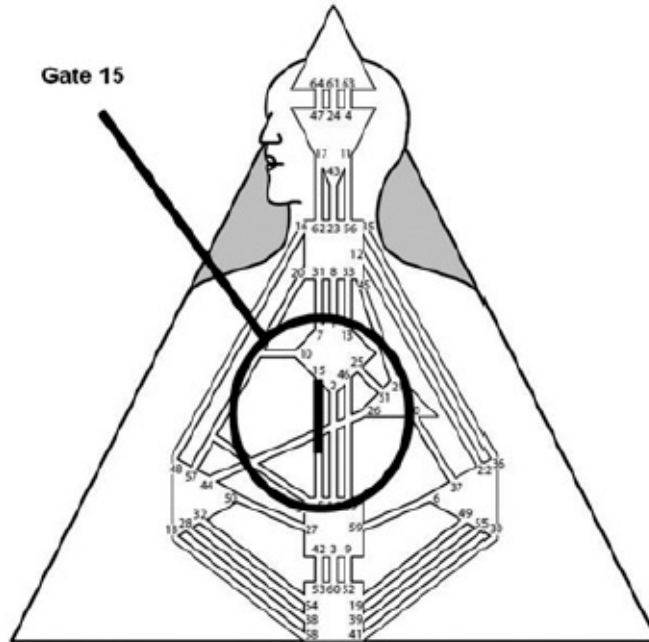

Figure 65: Gate 15

Gate 15 is a powerful, multifaceted energy. This is the gate of extremes—particularly extremes in rhythm. People with Gate 15 are always trying to find their rhythm, but it changes all the time. If they can find a consistent rhythm, it will be different and extreme. This can sometimes make relationships challenging, especially if a person with Gate 15 is in a relationship with a person with Gate 5.

People with Gate 15 have a big aura. They are usually aware of it and try to hide, but they can't. The aura of Gate 15 walks into the room before the person actually does. Everyone really is turning around to look at you!

Gate 15 represents the love of humanity. The Gate 15 can lead to extreme expressions of love for humanity. This can be a martyr gate. Hopefully it is paired with Gate 10 so that it can also be about empowerment.

This energy not only gives us a deep connection to our divine siblings, but it also ties us to the natural world. It is the energy for nature, flow, animals, and the elementals. The energy here clearly shows us that our fate and the fate of the natural world are inextricably intertwined. When we work with the fifteenth gate, we are called to ask ourselves what contribution we want to make to the world and to our divine siblings.

Affirmations

- My life adds to the greatness of humanity. My work benefits the world.
- I accept unconditionally the broad spectrum of diversity and rhythm that makes up humanity, and I surrender to the larger flow of life.
- I am in awe of the magnificence of mankind, and my awe inspires me to be of service to the greater good.

Writing Assignments

1. Where do you have rhythm, and where do you need to adjust your rhythm to be more “in the flow”?
2. What does the natural world seek to share with you? Do you need to align yourself more with nature?
3. What contributions are you making to humanity? Are you acknowledging your service? Do you need or want to deepen your commitment?

Gate 16: Skills

I Ching: Enthusiasm

Astrology: Gemini

Biology: Thyroid and parathyroid

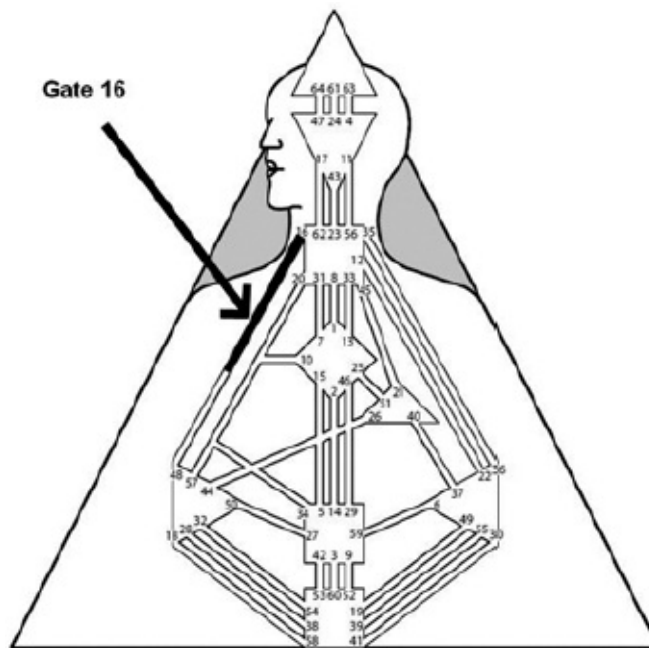

Figure 66: Gate 16

Gate 16 is enthusiasm without depth (unless it is paired with Gate 48). This is the “just do it” gate; it will just do things and figure out the details later. The good news is that Gate 16 is usually imbued with natural talent and can often get away with the superficial expression of talent it carries.

Gate 16 gives us the energy to leap out of bed and get truly excited about our creative endeavors. This is the gate of skills, but not so much depth, so there is youthfulness in our excitement. We still have much to learn as we master our creative process, but, like the Fool card in the Tarot, every journey starts with an excited first step.

Affirmations

- I allow myself to experiment and create.
- Experimentation and exploration are natural parts of my creative self and allow me to find the correct pattern for the expression of my talents and my soul's journey. It is in the relentless pursuit of this journey that I live my joy.

Writing Assignments

1. What dreams are beginning to come to fruition? What is your experimentation teaching you? What do you need to tweak?
2. What beliefs may be part of creating the manifestation of your experiments? Are there any old beliefs that you need to release?

Gate 17: Opinions

I Ching: Following

Astrology: Aries

Biology: Anterior and posterior pituitary glands

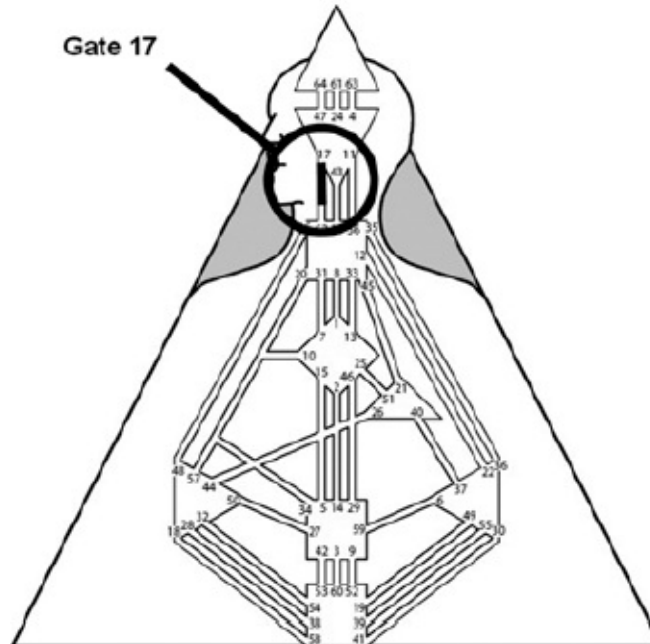

Figure 67: Gate 17

With the energy of Gate 17, we launch new ideas, ideas that are still to be proven. It's an energy of curiosity, not certainty. The energy of logic is mastery over time through correction of patterns. Gate 17 is the first corrective energy we see in the Logic Circuit (see [chapter 9](#)), but it is really an illusion. Without energy for proving and mastery over time, Gate 17 is just opinions.

This energy can be really hard for people to carry, especially if they are not good at waiting for people to ask. Gate 17 just plops out those opinions, not always recognizing that opinions are just ideas. Without recognition, the opinions are often energetically repelling, and the giver of the thought is ignored.

Gate 17 is merely proposing an idea, and when people with this gate can learn about the beauty of their idea instead of acting with certainty that their thought is correct, they can play their part in creating collective mastery.

Think of Gate 17 as the part of the scientific method that is about setting up a hypothesis. Remember that a hypothesis is a statement that is designed to be experimented with in order to see whether it is true or not. Opinions may or may not be true. They are designed to be experimented with so they are, in essence, new ideas that need to be tried out.

In its lowest expression, this gate is all about blurting out opinions. In its highest expression, it is an opening for a new possibility or a new pattern.

Affirmations

- I wait to offer my insights until I am asked. I know that when people ask, they will truly value my insights.
- I am aware that what is truth for me is not always truth for others. Each one of us has our own unique journey, and our perceptions create our understanding.
- I serve the truth and wait for those who are aligned with my truth.

Writing Assignments

1. What do you do with ideas and inspirations that spark your enthusiasm? Are you good at holding on to ideas and allowing the right people to be drawn to the “germinating” phase of your creation?
2. What does the phrase “to serve” mean to you? Are you being of service? Do you want to do more? Can you serve yourself without guilt?

Gate 18: Correction

I Ching: Work on What Has Been Spoilt
Astrology: Libra
Biology: Spleen and lymphatic system

Gate 18 is the intuition to make things perfect. It is the gate of the editor and the accountant. This is also a splenic gate, so there is no thinking here, just intuitive understanding. And, of course, fear. The fear of this gate is that nothing will be perfect, and as with all splenic gates, there is potential for someone to shut down because they will “never get it right.”

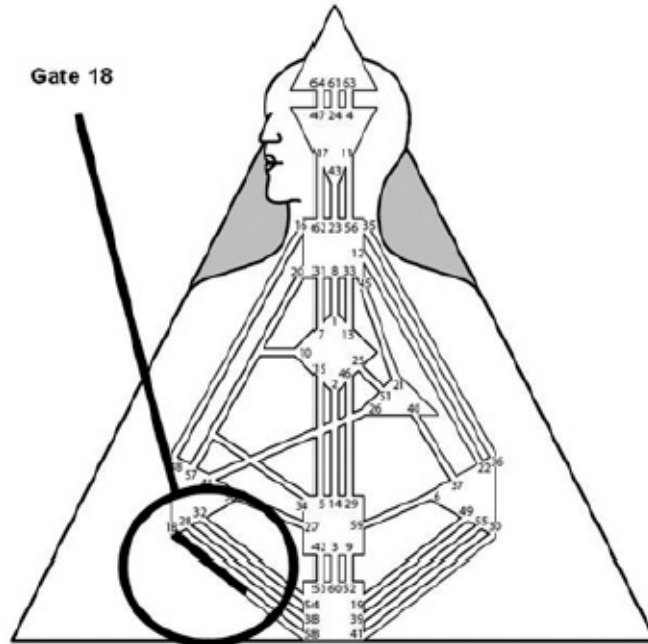

Figure 68: Gate 18

Gate 18 can feel harsh, especially if it is not recognized. There is no motor connected to Gate 18. The energy has to be recognized and called out by others. When it is asked for, it is brilliant and vital. We need people who can “fix” things and know how to make them better. They can find the perfect pattern and bring it out in a powerful way. This is the gift and the curse of Gate 18. And, of course, because it is intuitive and located close to the Root Center, often people with this gate feel pressured to share their correction. Oftentimes people will either react poorly, or they won't listen. Sometimes we call Gate 18 the “See? I told you so” gate.

Affirmations

- My entire life is a process of ever-expanding perfection. Where I am right now is the sum total of all of my experiences, and as I learn and grow, so does my understanding and consciousness.
- I am perfect right now. My so-called mistakes are catalysts for my growth, and I enjoy correcting patterns and bringing more and more alignment with my divinity into my life!
- Each and every day offers me opportunities to grow and expand, and I am grateful!

Writing Assignments

1. When you look at your life, what patterns of success are you aware of? What can you do to encourage these patterns to keep repeating?
2. When you look at your life, what patterns of self-sabotage are you aware of? What can you do to shift these patterns?
3. What do you need to work on releasing? Judgment? Forgiveness?
4. In your creative process, what needs to be tweaked in order to be brought into a more aligned expression?

Gate 19: Wanting

I Ching: Approach
Astrology: Aquarius
Biology: Adrenal glands

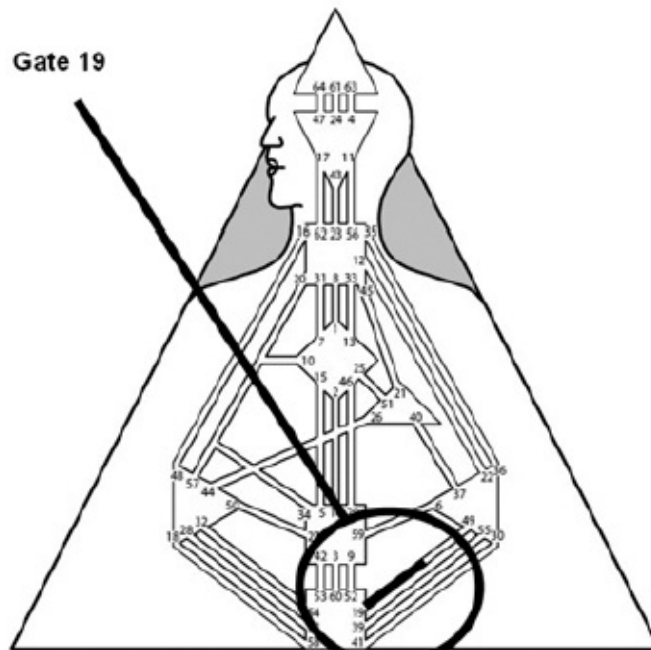

Figure 69: Gate 19

This gate is very sensitive. There is a real need for emotional honesty in this channel, as the emotional sensitivity helps make the decision whether to invest

in a relationship or not. If a relationship doesn't “feel good,” it is difficult to achieve intimacy.

The sensitivity of Gate 19 can manifest in many ways. It can be very sensitive to shifts in emotional energy. It is crucial that parents realize that kids with this gate must be disciplined in a very gentle way. Yelling, hitting, or other extreme emotional expressions can be very harsh for the child with Gate 19, especially if they are emotionally undefined.

Gate 19 can also be very sensitive to touch and feel. Emotional energy is all about touching, and the wanting that drives intimacy is rooted in the desire to be touched or not. True intimacy has to be felt on all levels of being. With true intimacy comes the decision to invest in the formal bonds of the relationship.

This can manifest as sensitive skin and tactile senses. Often people with Gate 19 will cut out the tags to their clothes, prefer soft fabrics, and even wear their socks inside out so as to avoid the seam pushing against their toes.

Gate 19 can also have a very sensitive palate. People with this energy may be able to discern the difference between the taste and texture of similar kinds of foods. For example, if someone with this gate switches brands of oatmeal, they may be able to tell the difference between the manufacturers.

Because Gate 19 also hooks into the mammalian chart and the energy of animals, it is often sensitive to the energy of animals. People with Gate 19 often benefit from having a pet as a companion.

Affirmations

- I know that the ending of cycles is always the beginning of the new. I take the blessings and the lessons I have learned from this cycle and move forward courageously into the next.
- I honor my sensitivity and trust my feelings.

Writing Assignments

1. What cycles in your life are coming to an end? What lessons have you learned from this cycle? Where have you gained clarity?
2. Are you resisting or allowing these conclusions? Is there anything you need to do to create space for the beginning of a new cycle?
3. What does intimacy mean to you? Are your needs being met? Are you meeting the needs of your partner? Are you asking clearly for what you want? Are you allowing your partner to give to you?

Gate 20: Metamorphosis

I Ching: Contemplation
Astrology: Gemini
Biology: Thyroid and parathyroid

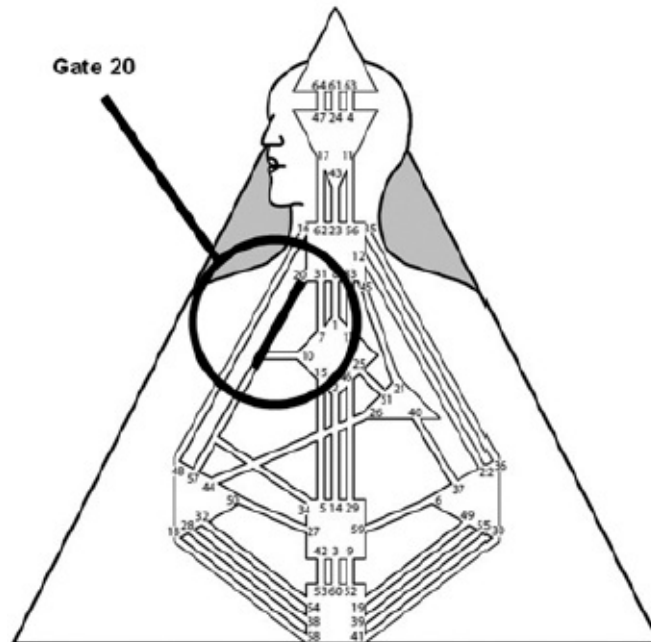

Figure 70: Gate 20

Gate 20 is powerful. It brings the entire Integration Circuit (see [chapter 7](#)) to the Throat, which dictates the expression (or not) of intuitive awareness to right action. Gate 20 has the potential to meet with empowerment, the self, intuition, power, and life force in a mutative way. It is an individual voice that can mutate and empower, or stagnate and disempower. (Remember, not all individual voices can be adaptive.)

When Gate 20 exhibits its highest potential, it is the expression of integrity—doing the right thing even if it isn't what others are doing. This can mean wearing green face paint in the forest when others are wearing bright pink or any other kind of “right” action that may be going against the flow.

Because Gate 20 is the expression of integration, it has within it inherent wisdom. In traditional I Ching, the twentieth hexagram is the wise king

standing on a hill, watching the wind to see which direction it will settle on before he takes action. As part of integration, Gate 20 takes time to express its wisdom. It watches and waits to express its higher knowledge, insight, and awareness. It metamorphoses awareness and recognition into action.

Gate 20 also recognizes the talents and skills of others. It is the great art critic or publisher, intuitively knowing the highest expression of awareness and self-expression. Gate 20 gives us one of the most interesting and counterintuitive dilemmas in the chart. We are deeply conditioned to believe that power and charisma are forceful energies, energies that aren't recognized without assertion or even aggression.

The Human Design chart shows us that the highest expression of power, charisma, and leadership is expressed only when recognized. Dictatorship and pushing your manifestations don't really work and usually only repel people.

True power lies in waiting for right timing, the right recognition, and preparing while you wait. People with this gate should take some time to align their desires, actions, and mindset. Plant the garden of your mind with the right seeds of thought, and fertilize with faith, trust, and knowingness. Let Divine Order prevail. Gate 20 promises that not only will the right chances materialize, but the right people will also be joined together in the process.

Affirmations

- Just because I can do it doesn't mean that I have to or that I should. I use my strategy to determine my actions, and I only do the things that are correct for me.
- I am a door to cosmic perfection and the entrance point for actions that create Divine Order. It is in my not doing that my doing becomes evident.

Writing Assignments

1. How do you feel about not doing?
2. Are there places in your life where you are busy without direction?
Are you battling burnout? Are you being as effective as you'd like to be?
3. Are there places in your life where you need to take leadership and delegate?
4. Define your personal power. Are you fully activating it?

Gate 21: The Treasurer

I Ching: Biting Through
Astrology: Aries
Biology: Thymus

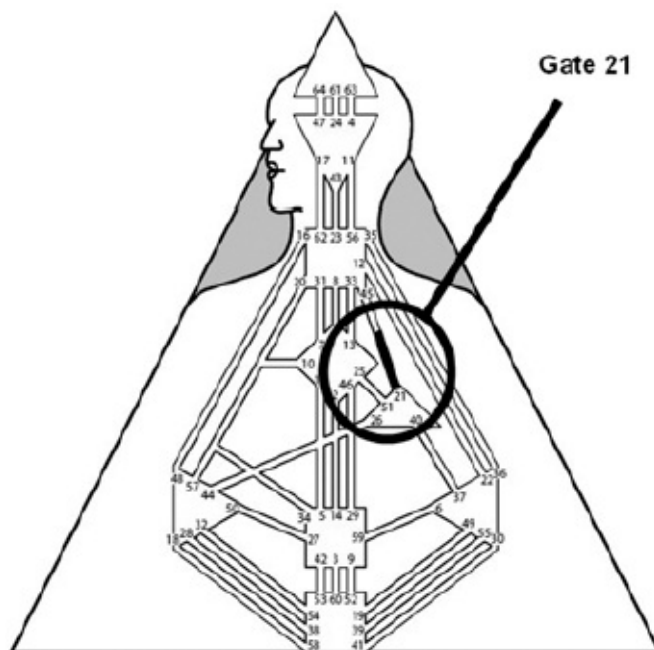

Figure 71: Gate 21

Gate 21 is the gate of the treasurer. It is here that we see the ultimate control of resources. This is a highly material channel that wants to control physical resources.

People with this energy love their things. They might buy a new car and park it way at the back edges of the parking lot in order to avoid door dings. Gate 21 can seem very controlling to others. Even though this energy has the potential to meet the Throat, on its own it is projected, meaning people won't allow themselves to be controlled unless they ask for it first.

When recognized, Gate 21 is a valuable resource for others. The wisdom of Gate 21 tells us when and how best to use our resources and spend our money.

While we may resist the control of Gate 21, it is a vital energy for sustainable abundance. Nobody likes a good treasurer, but everyone loves a full bank account.

Affirmations

- I control my thoughts and my actions. I release my need to control others.
- I use my energy to manage myself and trust that the Universe will provide all the serendipitous encounters and magic necessary to manifest my desires.
- My inspiration is a source of inspiration for others. I lead by example.

Writing Assignments

1. What things in your life do you need to let go of your control over?
2. What do you need to do to allow others to express themselves and to hold a space for their freedom?
3. What do you need to do to deepen your trust of Source? What old beliefs and fears need to be released so that you can move more deeply into Trust?

Gate 22: Openness

I Ching: Grace

Astrology: Pisces

Biology: Kidneys and pancreas

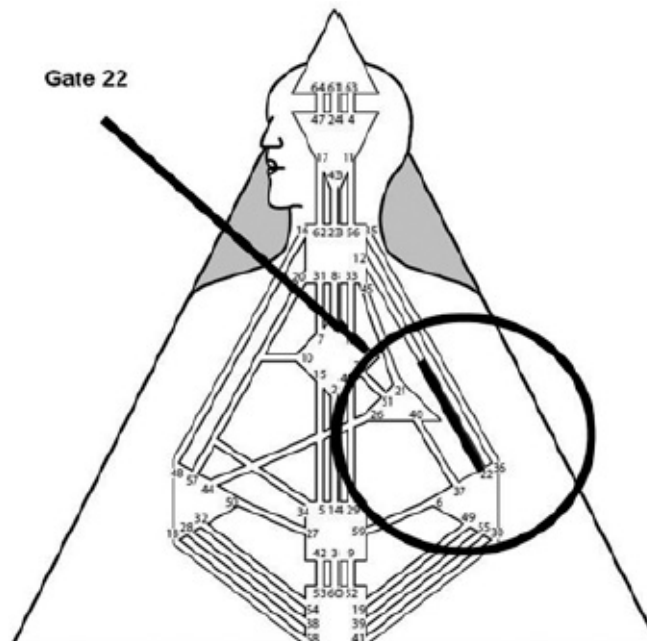

Figure 72: Gate 22

People with this energy can be very graceful and charming if they are in the mood. They know how to “work the room” and can be great fundraisers and sponsors. The true blessing in this gate comes from the realization that beauty and grace come from within, and that sharing this inner world needs to be done only with those who are willing to wait and cherish them. When inner beauty and grace are mastered, the right beholder recognizes the beauty and creates space for its expression.

Not understanding the inner world of beauty can become disgraceful. Acting on impulse, speaking out of turn, or improperly emoting can create an energy that pushes people away and removes the opportunity to transmit beauty. The person with Gate 22 needs to wait for correct timing and also inform before sharing.

With maturity, there is great wisdom, and this gate can learn to share when it's correct or silently sit and listen when it's not the right time. When it lives from true grace, this energy is compelling and gains attention.

Affirmations

- In the face of Divine Order, I stand with grace and presence.
- I see and evaluate, integrate, and share my awareness. I articulate the conclusions with grace and correct timing.
- I use my ability to perceive correct awareness to bring my awareness and understandings to others.
- I am the calm within the storm.

Writing Assignments

1. When faced with the emotional energy and drama of others, what is your strategy to allow and be aware? What are your strategies for detaching?
2. What is your style of teaching? When you recognize patterns, how do you bring your understanding forth?
3. Where do you create drama? How do you feel about your emotional energy? Do you wait for clarity, or do you jump in and clean up afterward?

Gate 23: Assimilation

I Ching: Splitting Apart
Astrology: Taurus
Biology: Thyroid and parathyroid

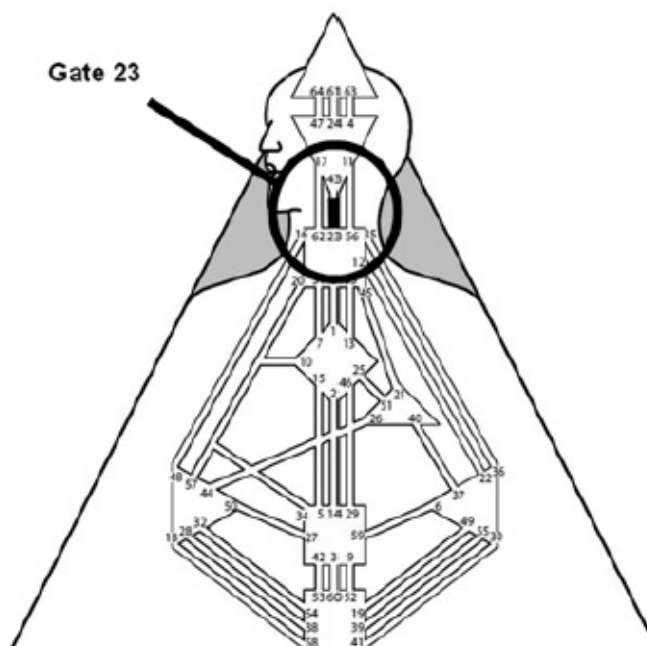

Figure 73: Gate 23

Gate 23 can be a real game-changer, as it recognizes that all foundations can be split apart with new thoughts and awarenesses. The real power to transform and serve as a catalyst for evolution lies in the capacity of Gate 23 to wait for correct timing. With correct timing, an invitation, and recognition, the words of Gate 23 can change the world—or at least the world of the person they are sharing their life with. If Gate 23 waits until the time is right, its insights can be perceived as genius. If Gate 23 does not have good timing, it can be perceived as “freakish” or ineffective.

Gate 23 continues the translation process of Gate 43. Gate 23 has the job of actually finding the words to express the mental mutation of the Knowing Circuit (see [chapter 7](#)). The gift of Gate 23 is that it can split apart the ideas of Gate 43 into small bits that can be articulated.

Affirmations

- My greatest strength is my ability to be still and wait to be asked to share the vision I hold.
- I stand with great confidence in my knowingness, and I trust that I know and hold the intention to create dynamic change for my own good and for the greater good of the whole.

Writing Assignments

1. How do you hold your vision? What part of your daily practice supports you in holding the energy of your intention?
2. Do you have the courage to hold on to a vision, even when no one else “gets it” or understands it at the moment? Is it okay for you to be on your own with your intention? How do you feel about not fitting in? When do you quit? When do you hold steady?

Gate 24: Rationalization

I Ching: Returning

Astrology: Taurus

Biology: Anterior and posterior pituitary glands

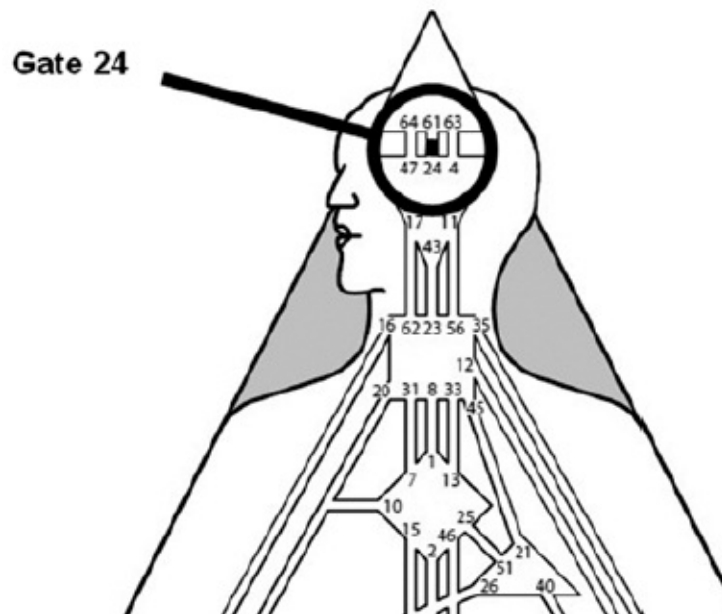

Figure 74: Gate 24

Gate 24 is the energy for rationalizing. In the mutative process, Gate 24 says “two steps forward and one step back is still one step forward.” The more you study Human Design, the clearer it will be that every step of expansion is followed by a contraction. We never go back to our original placement, but there is a grounding of expansion that allows for its correct progression. I lovingly call this “re-tweaking.” Gate 24 has the ability to find what truly works in the knowingness of Gate 61 and creates focus in that direction.

It is a powerful energy for moving forward that requires focus, intention, and a precise letting go of the mutations that are not adaptive. With this energy, we can rationalize what has been and what is, and make the best of it to create something new.

The rationalization of Gate 24 is also projected. The rationalization has to be invited to be shared and adapted, otherwise we think it's crazy or dysfunctional. You actually *can* rationalize anything. With an invitation, the rationalization of Gate 24 is reasonable and functional. Gate 24 is auditory, mutative, and also melancholic. Sometimes it's hard to rationalize, even though you can.

Affirmations

- I give my attention to my progress and all that is good.
- I focus on what is working, what is aligning, and I trust that all that is good will grow.
- I celebrate my successes and focus on creating more success by simply attending to that which is correct for me.

Writing Assignment

Make a list of everything that feels good and is working in your life.

Gate 25: Love of Spirit

I Ching: Innocence
Astrology: Pisces
Biology: Liver

We move from the shock of initiation into the love of Spirit. Here we have a

sweet, loving energy that has absolutely no shock in it. This is pure love, and you feel it when you stand in the aura of this energy.

The challenge for people with Gate 25 is understanding why other people do the things they do. When someone with this gate witnesses something they perceive as not loving, they can be confused. But if they try to speak to the situation, they cannot change it. The challenge of this energy is to *be* love while refraining from spreading love unless invited. Again, there is no convincing or talking here—only being.

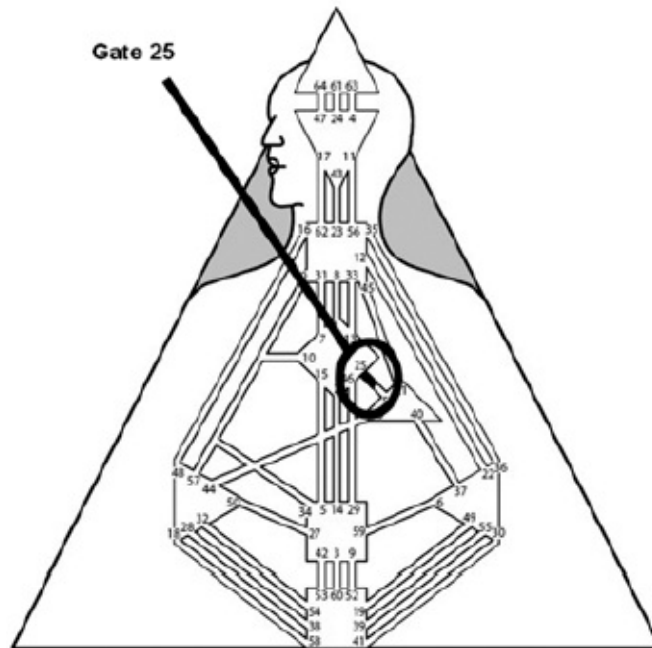

Figure 75: Gate 25

Gate 25 has very powerful healing abilities. If you have this energy you are a natural hands-on healer and do not necessarily need any training. When you have an open Spleen and Gate 25 you are natural healer and medical intuitive who can heal with the power of love. Truly, the twenty-fifth gate tells us that what the world needs now is love, sweet love, for everyone.

The energy of Gate 25 asks us to surrender our human understanding and judgments and embrace the concept of a love that is bigger than all of us.

Affirmations

- I am perfectly prepared to take my place in Divine Order.

- I know that my intentions can and will be fulfilled according to divine mind, and I relax and trust.
- I know that there are greater unexpected outcomes that are for my higher good, and I trust that all is well.
- I turn a blind eye to how things look and know that the truth will be revealed to me when I need to know.
- The spirit of God within me is the source of all my good.

Writing Assignments

1. How much do you trust in Divine Order?
2. For any given challenge in your life right now, ask yourself, “What would love do?”

Gate 26: The Trickster

I Ching: The Taming Power of the Great
 Astrology: Sagittarius
 Biology: Thyroid

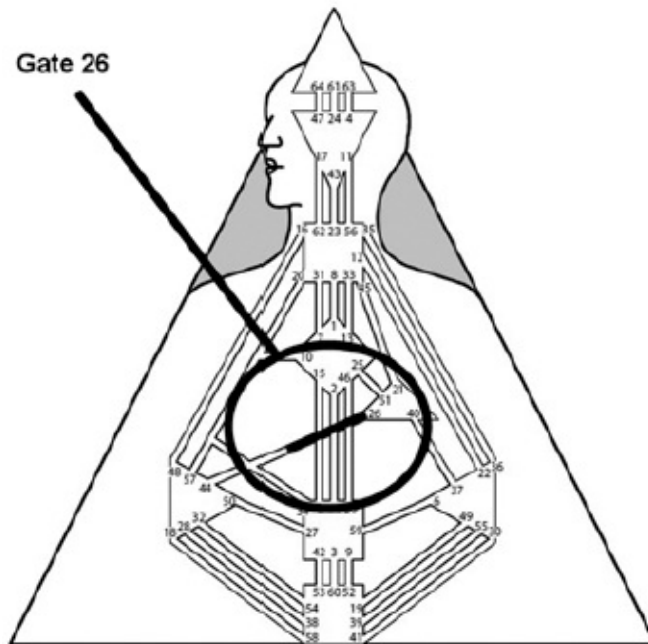

Figure 76: Gate 26

Here we have the gate of the salesman. Gate 26 has the energy to orchestrate the closing of a deal. It has the energy to transmit that the dream is a great idea and should be “bought” by the tribe. The tribe then, of course, delivers the resources to bring the dream into form. Gate 26 can be tricky, though. The energy here is truth or not. A good salesman will sell you a good dream and fulfill the promise. But the energy here is about sales. Sometimes a salesman will sell just to sell, and then he ends up being a snake-oil salesman.

The ultimate expression of this gate is about integrity. Gate 26 will express the lessons from the past and has the power to shape the identity of the tribe based on how it presents the past. Think about it. History is mutable. This gate can make history be whatever it wants it to be and then presents that version to the tribe.

Of course, this gate is also connected to the Will Center. So now we see a break in the workaholicism. The ego doesn't need much recognition, just enough and then it's time to rest. The trickster gets you to give him money so he can run away and rest. Or he will sell the dream, get it started, and let others do the hard part. (Think of the salesman from *The Music Man* who sells a set of imaginary instruments to a group of naïve small-town people.) This is, after all, just sales. The contracts and finances for deals are contained in other parts of the circuit.

Affirmations

- I speak and act with integrity, and I share my heart freely with my loved ones.
- I take my time to speak the perfect words because I know that my words are representations of my heart and my inspirations.
- I care deeply about my impact, and I listen with love to those around me.

Writing Assignments

1. Are your actions and words in alignment with your intentions?
What do you need to do to bring them into alignment?
2. What truths do you need to share from your heart? What heart-to-heart connections do you want to make this week?
3. What do you truly value in your life? Are you sharing your appreciation?

Gate 27: Responsibility

I Ching: Nourishment
Astrology: Taurus
Biology: Ovaries and testes

The caring of Gate 27 is all about responsibility and education. A well-fed tribe has optimal neurological development, which allows everyone to continue to live out the values of the tribe. Gate 27 has a responsibility to transmit the values of the tribe through education and disbursement of resources. It delivers the food and teaches the tribe how to grow and distribute more.

This is not a relaxed energy. This is tribal energy, after all. The pressure of responsibility is undeniable, and the transmission and nurturing can happen at great cost to the individual but can reap great rewards for the tribe.

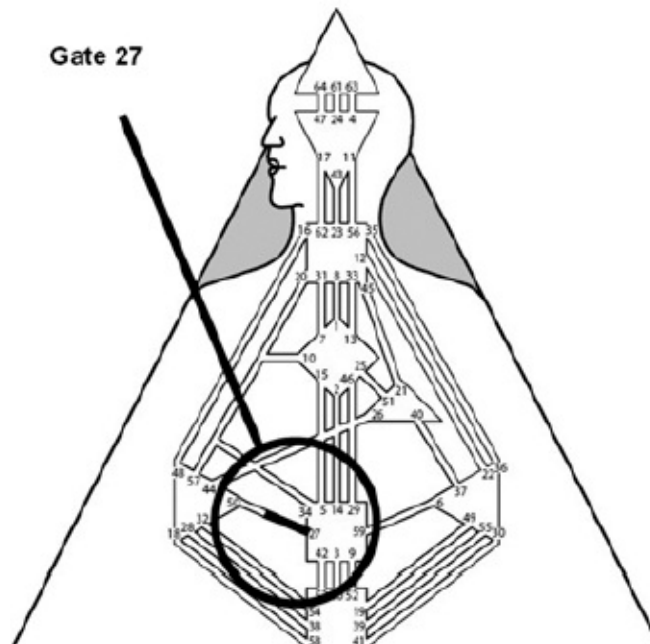

Figure 77: Gate 27

This is the energy of Mother Teresa: caring, responsible, impactful, and educating; sacrificing the individual for the greater good of the whole.

A healthy expression of this energy gives you the power to own what is yours and to hold others accountable for their responsibilities.

Remember, you cannot force someone else to evolve. They have to choose to evolve for themselves. If you are trying to be responsible for someone else's happiness, you will just waste precious energy and give up your own happiness in exchange.

Affirmations

- I trust that when faced with challenges, I will know exactly what to do.
- I take care of myself and then others so that my energy is strong and my capacity to care is limitless and empowering.
- I empower others to assume responsibility for what is theirs and see them as fully capable.

Writing Assignments

1. Are you doing things for others that they could be doing for themselves? What actions do you need to take to empower them and you?
2. What is your core message in your life right now? Where do you need to focus your energy to fulfill the transmission and manifestation of that message?
3. Are you dependent on the approval, permission, or recognition of others? Are there any people in your life that you need to stop trying to keep happy?
4. Could you be better about taking care of yourself? If so, what do you need to commit to?

Gate 28: Struggle

I Ching: The Preponderance of the Great
Astrology: Scorpio
Biology: Spleen and lymphatic system

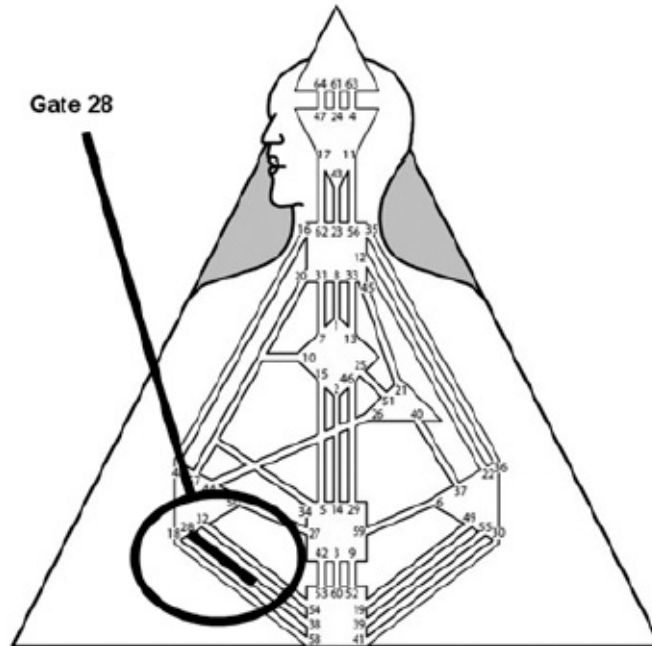

Figure 78: Gate 28

Gate 28, the gate of the game player, is a splenic energy that is rooted in the fear that life has no meaning or value. Gate 28 has to struggle to discover that meaning. But it has to be the correct struggle—otherwise it is meaningless.

Sometimes people with this energy will feel that life is not fair. It may seem like life is so much more difficult for them than it is for others. To a certain degree, if people with Gate 28 are not following their strategy by type, this can be true. Gate 28 gives a chart a default program of struggle. If you have this energy and you live your strategy, you will engage in the correct struggle, and these struggles will help you discover and share the meaning of life. But if you don't live your strategy, it's possible you will focus on the wrong struggles, which just makes life feel hard.

When you don't have Gate 28, it's hard to imagine that struggle can be fun. But people with Gate 28 can actually learn to embrace the struggle. When the value of life has been mastered, Gate 28 enjoys the challenge. They like pushing the envelope. This is joyful engagement in the challenge of life and taking life to the extreme.

The struggle is challenging, but surmounting the struggle has tremendous payoff with this gate.

Affirmations

- I am fully alive. I am constantly present to the energy and possibility of life.
- My experiences and struggles help me define what is truly valuable in life, and I love the challenge!

Writing Assignment

We often ask ourselves what we can pursue that is worth dying for. Instead, try asking yourself: What in your life is worth *living* for?

Gate 29: Perseverance

I Ching: The Abysmal
 Astrology: Leo/Virgo
 Biology: Ovaries and testes

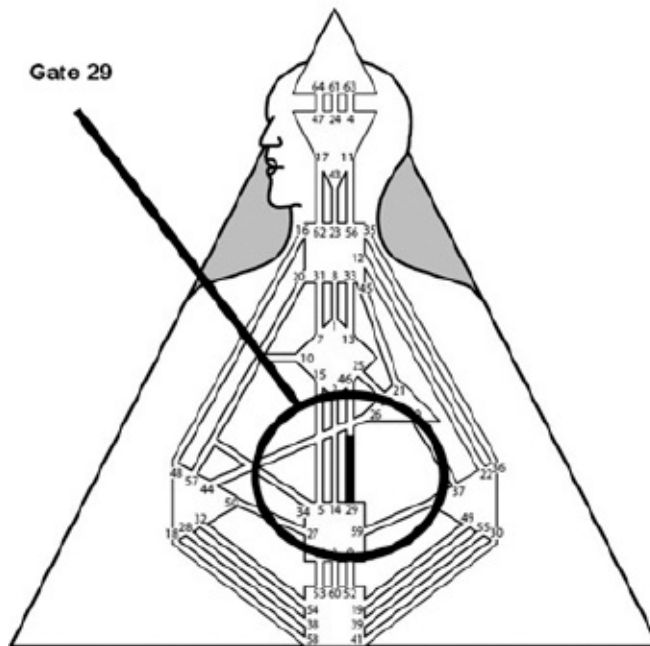

Figure 79: Gate 29

Gate 29 has a tendency to say yes to everything, especially when it is not using the Sacral strategy of response. Gate 29 is designed to be perseverant and determined, and part of that expression is the commitment to do.

When Gate 29 is not living its strategy, it can commit itself to death. It is not

uncommon to see autoimmune disorders and physical symptoms of burning out when Gate 29 is not responding. Gate 29 seeks commitment, but it must be the *right* commitment. When it responds, it carries the energy of being able to withstand the trials and tribulations that can lead it to success. But the wrong commitment can make Gate 29 hold on for longer than is healthy. This can be a bad combination, especially with an open Spleen, open Emotional Solar Plexus, or open Will Center. Too much holding on, proving, or empathy can wear Gate 29 down.

The power of Gate 29 lies in its ability to persevere no matter what. This is the commitment and the determination of the Olympic athlete or anyone who is determined to make a dream a reality.

Affirmations

- As I prepare myself to emerge from my creative cocoon, I carefully examine my actions and make sure that my commitments are in alignment with my intentions.
- I only say yes to the things I know will bring me closer to fulfilling my dreams, and I enter into my commitments according to my Human Design strategy.

Writing Assignment

1. Are there areas of your life where you have outgrown your commitments? What circumstances and situations do you need to release to make room for new commitments?
2. How hard is it for you to say no? What keeps you from saying no to yourself or to others?

Gate 30: Desire

I Ching: The Clinging Fire
Astrology: Aquarius/Pisces
Biology: Pancreas

Gate 30 brings us the energy for intensity and desire. In the traditional I Ching, this energy is called the clinging fire.

The theme of this channel is to wait for the right timing to express or take action. Gate 30 gives us the energy to hold on to an idea and let it simmer until the timing is right. Gate 30 has an intense tenacity that can often drive other people insane or burn them out. But when acted upon correctly, it gives us the passion and the drive to manifest the next new experience.

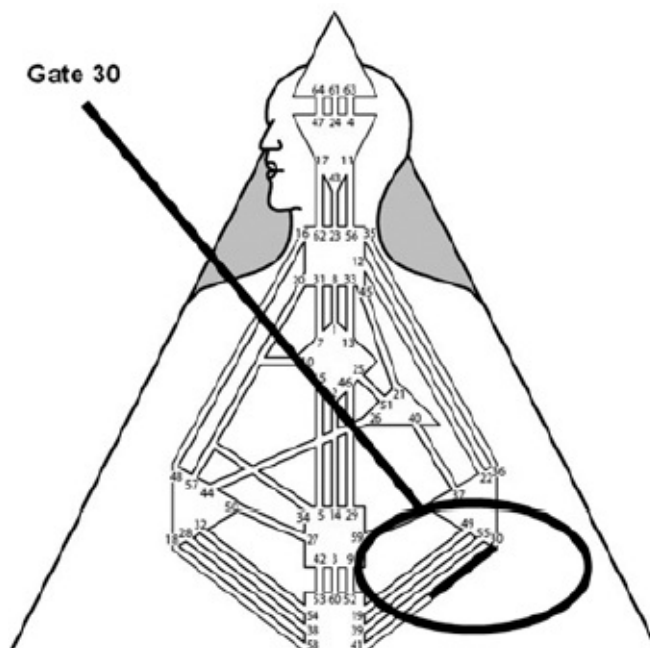

Figure 80: Gate 30

Gate 30 is all about creating new experiences. New experiences can be life-enhancing or chaotic, or maybe a little of both. Waiting for the right timing is crucial, but it is also challenging for this gate in particular. It's under pressure. It has desires. It longs to express itself. It's emotional. It's juicy.

If this gate wants to express itself correctly and not push others away with its intensity, it has to wait and be mindful of the fact that most other people will not be so intense.

Affirmations

- I am clear about my intentions and desires. I only focus on what I want. My vision is true, and my passion is fed by the fire of my heart. I am unwavering and powerfully focused.
- I honor myself for creating the space to bring forth my dreams and

intentions.

- My life is completely open to receive, and I stand in a passionate place of anticipation for the manifestation of my desires.

Writing Assignments

1. What do you want in your life? What do you choose to experience in your finances, your health, your relationships, your creative fulfillment, your spiritual life, and your lifestyle?
2. What distractions do you need to remove in order to keep your focus sharp?
3. What are you passionate about? Are you free to express your passion? What keeps you from your passion?

Gate 31: Democracy

I Ching: Influence

Astrology: Leo

Biology: Thyroid and parathyroid

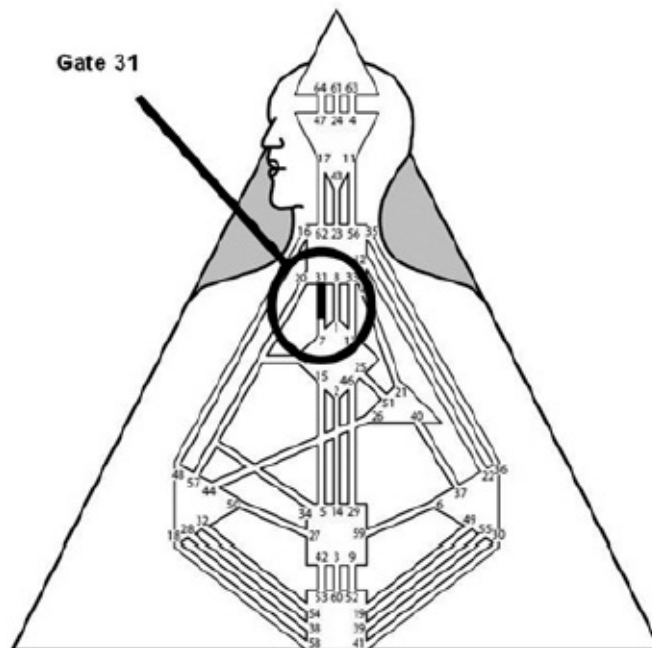

Figure 81: Gate 31

With Gate 31 we have natural leadership that must be recognized in order to be effective. This is the expression of democracy . . . leadership that has been proven effective over time through repeated applications of theory. This gate serves best when it seeks to serve the people. The best question to ask yourself if you are working with this energy is, “How may I be of service?”

Let the group you are leading tell you how they want to be led. This is the real secret to being an effective leader with this energy. You are simply the figurehead. Unify the group, and be ready to delegate and share the power.

Affirmations

- I assume my position of natural leadership when I am invited to assume influence.
- My words, thoughts, ideas, and dreams are important and worthy of sharing with the right people.

Writing Assignment

Meditate on what true power and influence mean to you. Notice where you feel power in your body, and practice connecting with this physical feeling at least once a day.

Gate 32: Continuity

I Ching: Duration

Astrology: Libra

Biology: Spleen and lymphatic system

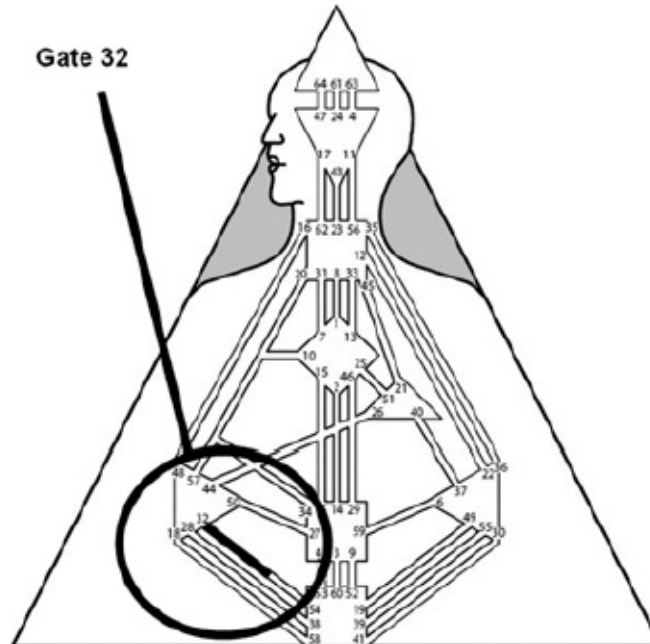

Figure 82: Gate 32

Gate 32 is the intuition to know when a dream is worth bringing into form and reality. Gate 32 wants to provide the energy to make it happen, but it has no energy of its own. Here we have the intuition and wisdom to know that something could be transformative and successful, yet the entire process rests on whether or not someone recognizes the value. It requires an enormous amount of trust. Gate 32, rooted in the Spleen, is a fear gate. Gate 32 says, “What if my dreams are all for naught?” Gate 32 has a tremendous fear that someone else will take their dream and make it a success or that if they implement their dream, they will fail.

In its high expression, Gate 32 is an evaluator but not a doer. The true power of Gate 32 is in recognizing which ideas are worthy of energy expenditure and which ideas can simply be released.

Affirmations

- I intuitively know which ideas are worth pursuing.
- I am wise about what will work, what will create resources, and what needs to happen to turn a dream into a lucrative and impactful endeavor.
- I trust that the right people and the right resources will be attracted to me so I can easily share my wisdom in a way that values me and my ideas.

Writing Assignments

1. What would an unlimited life look like to you? What would you do? What would your business look like?
2. What leaps of faith would you need to take to make this dream life a reality? What new commitments would you need to make?

Gate 33: Privacy

I Ching: Retreat

Astrology: Leo

Biology: Thyroid and parathyroid

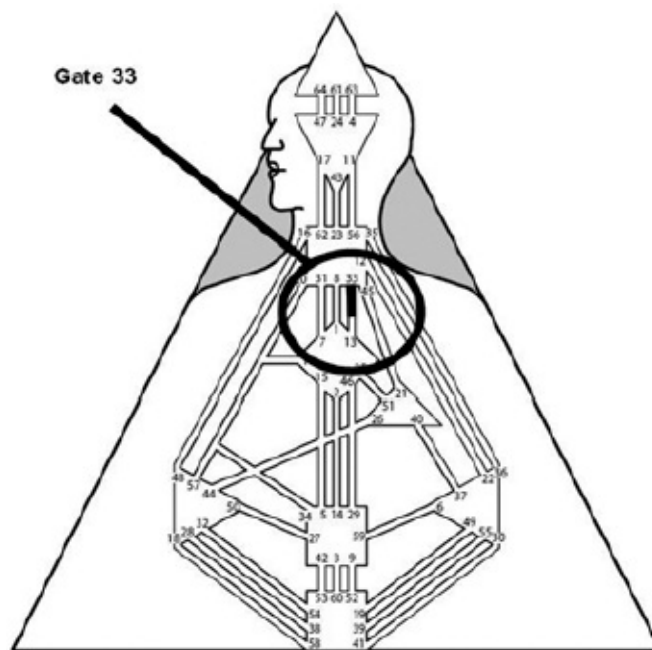

Figure 83: Gate 33

Gate 33 innately recognizes that the stories of people's lives are sacred and vulnerable. This is where memory is stored. Gate 33 takes the energy of the witness and holds on to the memory, only sharing the memory if the timing is correct.

The danger with this energy is that in its lowest expression, it holds on to the

past, fearful of the possibility of it repeating itself. This can cause someone with this gate to become stuck, fixated on what's already happened—especially if they are not waiting for the recognition to share their story. The stories of the past require time for reflection in order to discover the right way to share in accordance with the sacredness of the memory. It is in the aloneness that Gate 33 realizes what needs to be shared and what needs to be released, forgiven, and forgotten.

In its highest expression, Gate 33 shares the stories from the past, maintains the memories and the history of the collective, and shares when the timing is correct.

Affirmations

- I continue my journey inward, working with the cycles of creation and repose.
- My focus now is on my past, my journey, and the evolution of my future.
- I relax and trust that what is hidden will be revealed and truth will be demonstrated. My greatest power is in divine timing.
- I trust. I wait. I know. I grow.

Writing Assignments

1. If you have not seen the results of forward momentum in your life that you have intended for this year, what do you think is holding you back? What storyline are you living? Write the story of your limitation or label.
2. Rewrite that story as if it weren't true for you anymore. What would change? What would the end results be?

Gate 34: Power

I Ching: The Power of the Great

Astrology: Sagittarius

Biology: Ovaries and testes

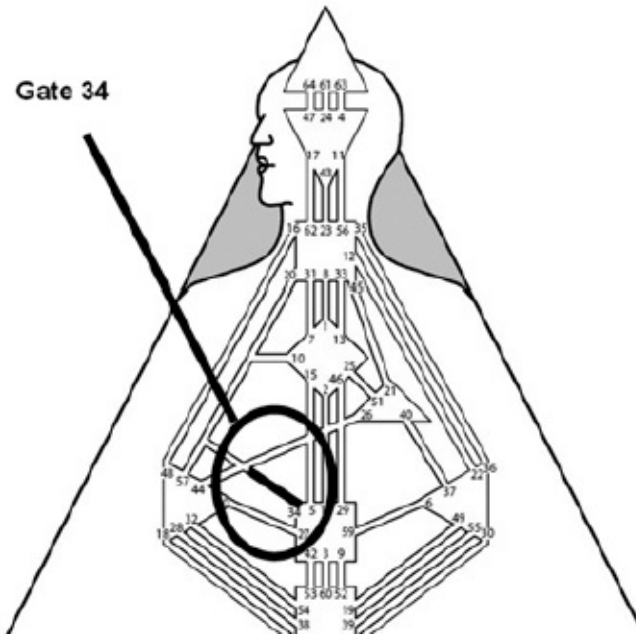

Figure 84: Gate 34

Gate 34 is the busiest gate in the chart, and one of the most powerful. Because it is rooted in the Sacral, it is generated energy-and life force-based. This is the only gate coming out of the Sacral that has the potential to be asexual. Sometimes people with Gate 34 can be too busy to have sex. (Or they can be very busy having sex.)

Gate 34 is the base gate for the Manifesting Generator, so it has the potential for great power, but there is an irony associated with the power of Gate 34. It is powerful only when it responds. It is generated, not manifested. Generators with Gate 34 who push and initiate their power will not be successful in the expression of their power, and consequently will feel very frustrated.

Generators with this energy often have a hard time distinguishing between pushing and manifesting. The wiring in this part of the chart is so complex and fast that sometimes it's hard to slow down enough to see if you're responding. It's good for people with this energy to practice visualizing the outcome of their choices before they leap into things.

Gate 34 is the “multitask” gate. A person with this gate is designed to have many things going on at once, and it is crucial to look at where Gate 34 connects in a chart. This will determine the expression of Gate 34.

People with Gate 34 are often told to slow down and to pick one thing and stick to it. That's good advice for some people, but not for people with this energy. Gate 34 has to be busy. If it's not busy, it's like trying to trap a lightning

bolt in a glass jar. Eventually, the lightning bolt will ricochet around in the person's body and hurt their health.

If a non-Sacral person has Gate 34, when their Sacral gets under pressure they will be the busiest people on the planet, but not sustainably.

Affirmations

- I trust the Universe to deliver the perfect opportunities to fulfill my dreams and intentions.
- I watch and wait for signs that clearly show me the next step.
- I know that my true power is in co-creation with the Universe, and I know that divine mind has the perfect path for me.
- Being busy is healthy for me, and I honor my need to do many things at once.

Writing Assignments

1. How are you leveraging your power and energy? Are you doing things that are not bringing you closer to your dreams? What things do you need to stop doing in order to create a space for what you truly want?
2. What is your definition of power? Do you feel powerful? What can you do to be more powerful in your life?
3. What do you need to do to deepen your trust in the Universe? Are you showing up and doing your part in your life?

Gate 35: Change

I Ching: Progress

Astrology: Gemini

Biology: Thyroid and parathyroid

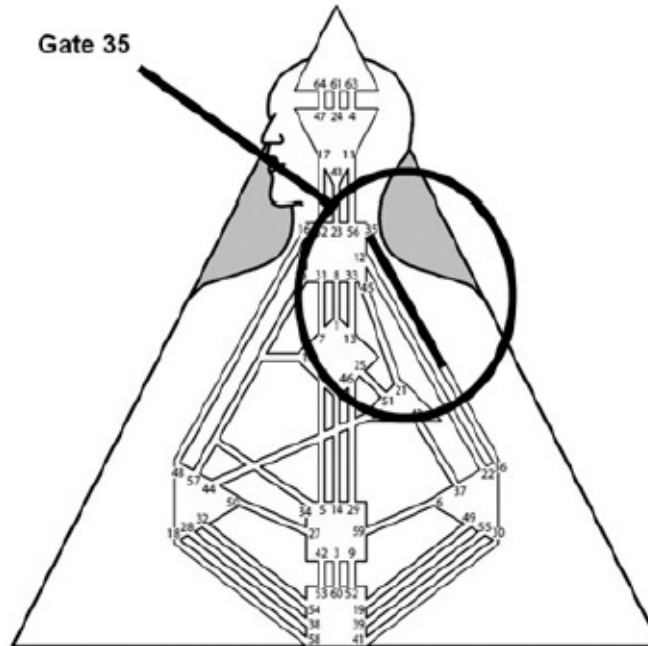

Figure 85: Gate 35

Gate 35 is the final expression of experiential energy. This energy follows fantasy and desire. It's tried everything, had every experience, and it is capable and sometimes jaded.

There is a maturity rooted in experience with Gate 35. It knows life and knows how to learn what's necessary. People with Gate 35 are rarely stymied about life. They understand the life experience and can, with little hesitation and limitation, learn just about anything.

The challenge of Gate 35 is finding an experience that can light it up and turn it on. Gate 35 is not inspired by the mundane. It seeks the experience that is worth its investment in time, energy, and resources. Gate 35 offers stories of life rooted in personal experience. You never know what story a person with Gate 35 may be waiting to tell. In the mature expression of this energy, Gate 35 knows that the real gift of the story isn't in the excitement, it's in the process, the emotions and the lessons learned. There is great wisdom here, and the stories of Gate 35 ultimately belong to all of us. They've done it all so we don't have to.

Affirmations

- I choose the kinds of experiences I desire.

- My feelings about my experiences show what is correct for me.
- I am responsible for my own choices and my own happiness, and no one can create experiences for me that I do not choose.

Writing Assignments

1. What is going on in your life right now that you would like to change?
2. In your current manifestations, what experiences would you like to avoid duplicating? How can that understanding help you get clear about your creation? What experiences do you need to focus on and align with?

Gate 36: Crisis

I Ching: The Darkening of the Light
 Astrology: Pisces
 Biology: Kidneys and pancreas

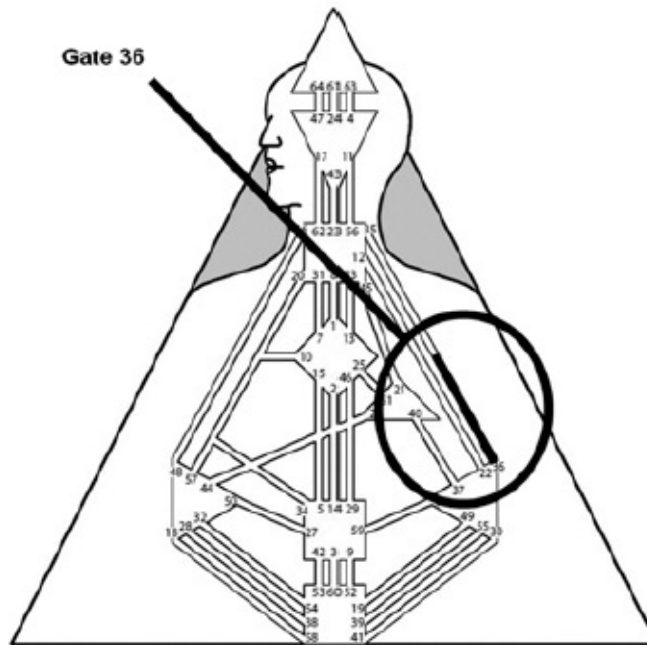

Figure 86: Gate 36

Gate 36 is the emotional impulse of desire. Gate 36 wants what it wants, and if it waits, it can have it. If it doesn't wait, it leaps into chaos and crisis. Gate 36 is

always longing for the next new experience. It is plagued by boredom and has a tendency to leap into things without waiting for clarity purely in pursuit of the next new experience.

If the desire of Gate 36 is to be a master of some kind, it needs to learn to temper its restlessness so it doesn't quit something before it masters the skills necessary for success. Gate 36 is all about desire and can be quite sexual in pursuit of fulfilling its desires. What we learn from the Human Design chart is that all sexuality is designed to be waited for and not acted upon impulsively, as the consequences of acting too quickly can be dire.

This is the gate that teaches us to temper our fires with time and even a bit of pragmatism. There is great value in learning to wait for the right timing.

Affirmations

- I embrace the new.
- I trust my intuition and my strategy, knowing that I make clear, intentional choices.
- I am the eye of the storm. My head is clear, my heart is aligned, and I only act for my highest good.
- I am immune to the appearances of my outer reality, and I know that I am on my way to creating what I intend. My beliefs are unwavering, and I am not swayed by outer circumstances.

Writing Assignments

1. What is your strategy for coping with unexpected events, chaos, and tragedy?
2. How strong is your connection to Source? What do you need to do to strengthen it?

Gate 37: Friendship

I Ching: The Family

Astrology: Pisces

Biology: Kidneys and pancreas

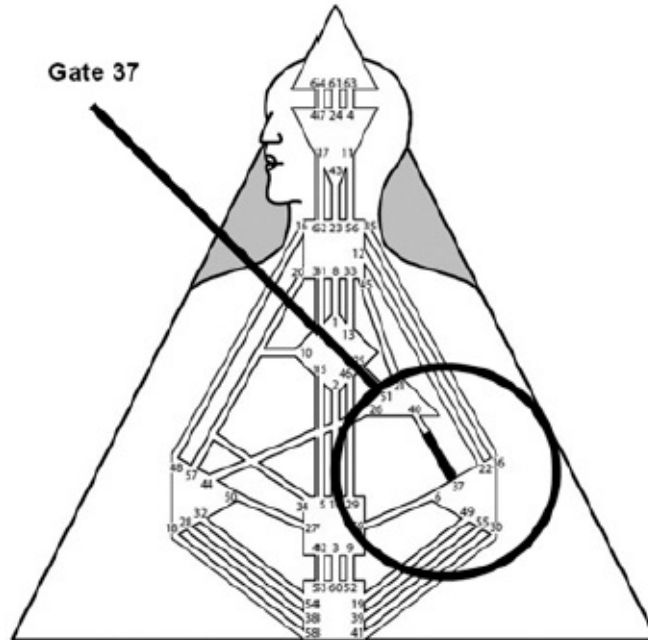

Figure 87: Gate 37

Gate 37 is a very clear and simple gate. It wants one thing and one thing only: harmony. Gate 37 will work for peace and, if the timing isn't correct, wait for peace. Gate 37 on its own seeks to join with others and communicate to create peace and harmony.

At the root of Gate 37 is the belief that when we all work together to create the resources necessary to sustain us all, then we will have sustainable peace. It is half of the Channel of the Bargain (see page 259) and is all about creating agreements and contracts. The intention of Gate 37 is to create agreements that foster peace and harmony.

If you do not communicate clearly with those around you, you run the risk of misunderstandings, which can hinder your progress. Whatever level this communication takes place on, you need to make sure that you are respectful, sincere, and very clear in what you mean.

Affirmations

- After the storm there is always calm. It is in the quietness that follows shift and change that I remember my bearings, breathe deeply, and realign my relationships with what is new.
- All agreements I make are clear and created with peace as the end goal.
- From the remnants of the past I discover my blessings, and I work with my

friends, my family, my tribe, my community, and my world to co-create a mutually respectful and deeply honoring peace.

- Peace is within me. I am peace. I breathe peace. I create peace. All is well.

Writing Assignments

1. How can you create a lifestyle that is more peaceful? Commit to doing five peace-enhancing activities today.
2. Are your agreements with your partners clear? Do all parties have the same expectations? Are there any clarifying conversations you need to have to deepen the awareness and clarity of your agreements?

Gate 38: The Fighter

I Ching: Opposition

Astrology: Cancer

Biology: Adrenal glands

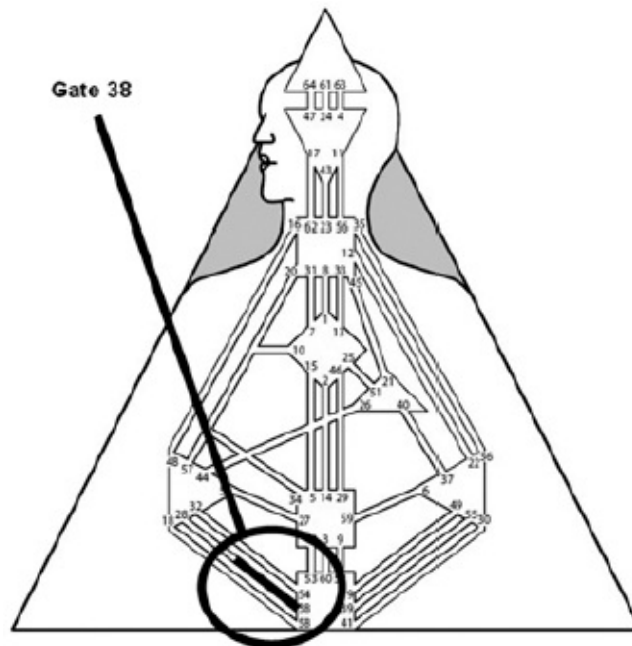

Figure 88: Gate 38

Gate 38 struggles to know what is worth fighting for. It seeks purpose and meaning to life and essentially pushes us (with adrenaline energy) to find our life purpose. Why are we here, and how can we live a life that reflects our purpose? What are the truly valuable things in life?

People who have this energy can be somewhat stubborn by design. When they have determined that something is valuable, they hold on to it, fight for it, and don't let go. They're people who can transform the world with their mutation if it survives the struggle.

This energy can also be somewhat provocative. This is projected energy, so it is designed to get our attention. We watch people with this energy struggle, and we either call them out to share what's happening with them, or we push them away and question their life choices.

There is a possibility here of feeling like you don't fit in, that life is a struggle and you're all alone. But wait for the invitation for the correct struggle, and Gate 38 will show what is worth fighting for and will help you to find the right people to share your wisdom with.

Affirmations

- I have deep clarity about my life purpose and direction. I persevere and fight for what I know has value.
- Serving my purpose inspires me and gives me the energy to take powerful steps forward in my life no matter what comes my way.
- I am here for a unique purpose, and I honor that purpose by setting clear intentions and taking actions that reflect that purpose.

Writing Assignment

Please visit the following website for a special Life Purpose Guided Meditation: www.understandinghumandesign.com. After you've completed the meditation, write about any insights you gained during the session.

Gate 39: Provocation

I Ching: Obstruction
Astrology: Cancer
Biology: Adrenal glands

Gate 39 holds a deeply emotional and rich energy. People with this gate can be very musical, creative, and passionate. This gate is challenging and provocative. The provocation can be lighthearted, teasing, and fun, or it can poke you, stirring up negative emotions and fear. Consequently, Gate 39 can be a little tricky for the people who have it and for the people who are affected by it.

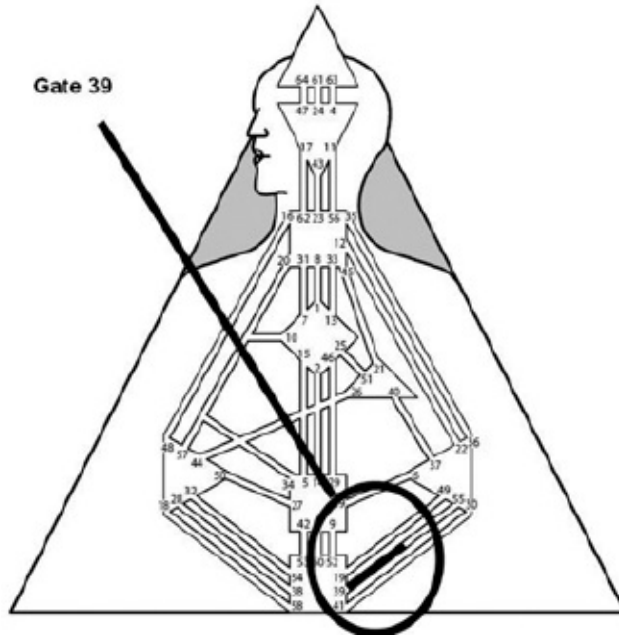

Figure 89: Gate 39

Gate 39 pushes us toward abundance. The provocation of Gate 39 is designed to restore our awareness of abundance and Spirit. We sometimes refer to people with Gate 39 as our “teachers”; they are people who have pushed us and poked us in ways that have made us uncomfortable and forced us to look beyond the immediate appearances of things.

On a more mundane level, the energy of Gate 39 can create eager shoppers, always on the hunt for a great bargain. People with Gate 39 feel good when their pantry is full (or even overflowing), and will often be nervous if they have to break into their stores of food. Often people with this energy will hoard and save things to a fault. They can be fearful that someday they may run out of something.

In its highest expression, Gate 39 pushes us out of thought forms and habits that keep us stuck in the idea that there is “not enough.” Gate 39, as provocative as it can be sometimes, has the power to help us see that the perception of “not enough” is an illusion and that with a shift in awareness and by refocusing on

the abundance of Spirit, there is always more than enough.

Affirmations

- I wait for the right spirit of things, for the right doors to open, before I progress forward.
- I recognize the power of my actions and words to provoke others, and I use this power with great care, knowing that I have the ability to create change in people's lives.

Writing Assignments

1. Describe a memory when the spirit felt right and a correct manifestation followed. Reconnect with that feeling and anchor it deep within your body and your consciousness.
2. Do you push people and opportunities away? Is it correct for you? Do you need to find more constructive ways to allow yourself more time to make decisions? What can you do to create an energy that is “allowing”?
3. What is your relationship with food like? Are you an emotional eater? Do you love your body? Are there changes you need to make in your relationship with food and your eating lifestyle?

Gate 40: Loneliness

I Ching: Deliverance
Astrology: Virgo
Biology: Stomach

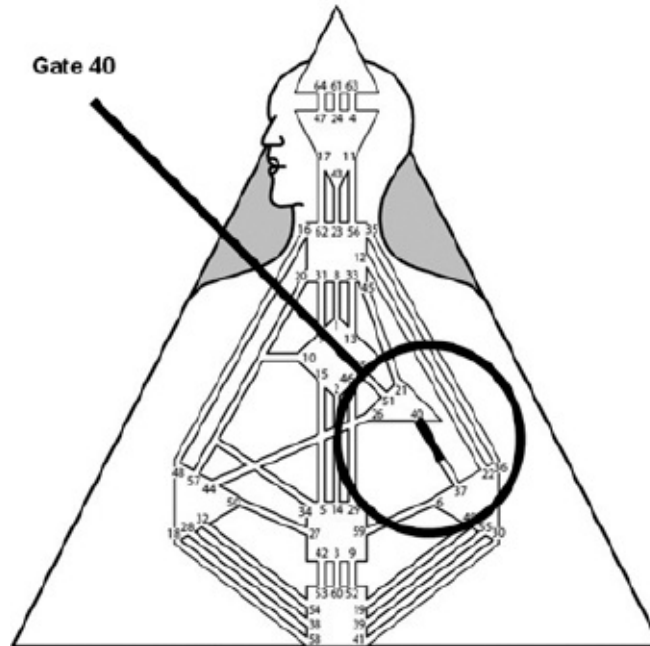

Figure 90: Gate 40

Gate 40 is one of the “alone” gates and requires a deep willingness to accept that its energy is “not personal.” People with Gate 40 need alone time but can also struggle with loneliness.

The energy of Gate 40 can feel deeply alone and lonely. But the truth of Gate 40 is that it drives a person to seek out others. In other words, Gate 40 is the energy of a part seeking a whole or a loner seeking a tribe. Gate 40 needs a tribe to spread and share resources with. Often we find Gate 40 in charts with a lot of mutative (individual) energy, creating the electromagnetic pull to find more tribal energy to share the mutation with.

People with Gate 40 need to look for the evidence of love and companionship surrounding them. It is very possible for people with Gate 40 to be standing on a pedestal surrounded by a crowd of bowing, adoring fans and still feel as if no one wants or loves them. This energy may feel lonely, but reality will show that this gate is not as alone and unloved as it thinks it is.

The loneliness of Gate 40 causes people to go out in the world and create new agreements and bonds so that the energy for creating resources is always renewed and evolving. In this way, Gate 40 plays a vital role in the energy of spreading new ways of forming agreements.

Gate 40 is also the gate of the stomach. People who do not understand this energy and try to use Will energy they do not have will often have stomach

problems. If a Generator has an undefined Will Center and Gate 40, they will often work and work and work and forget to eat.

The undefined Will Center with Gate 40 will often try to get away from a defined Will Center because the pressure of the defined Will Center will activate the need for aloneness with Gate 40.

Affirmations

- I relax in my knowingness that I am lovable and capable of allowing all the helping hands I need to make my dreams a reality.
- I seek out others and connect with an open heart and pure joy and love.

Writing Assignments

1. What is the nature of your relationships? Do your relationships feel balanced?
2. Do you feel lonely? Do you need to go out and make more connections with others? Network? Join social groups? Are you connecting with the family of man?

Gate 41: Fantasy

I Ching: Decrease
Astrology: Aquarius
Biology: Adrenal glands

Take a look around you. Everything you see that was created by man was once an idea, an idea that was manifested into form.

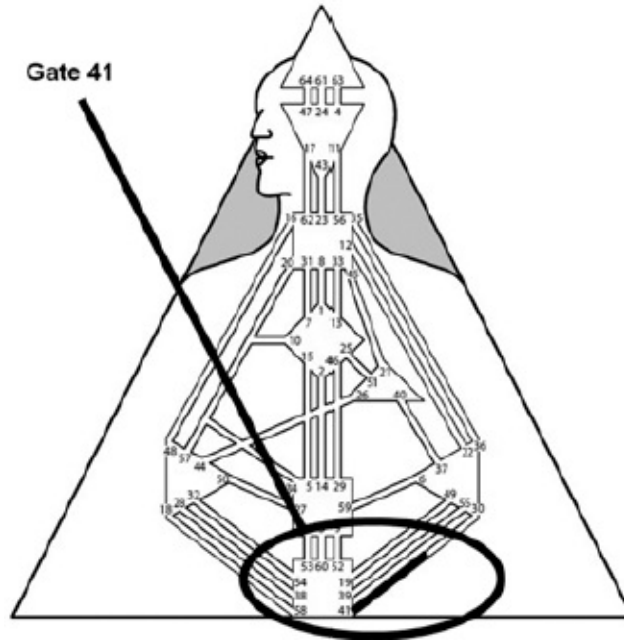

Figure 91: Gate 41

The Human Design new year starts with this gate. This is an initiating energy that ultimately brings new ideas or experiences into form. This energy can sometimes be experienced as daydreaming. Children with this energy are often accused of not paying attention while they fantasize about their abundant ideas.

The energy of this gate is well-suited for visualizing and imagining. While these are somewhat “mental” activities, what makes Gate 41 unique is that when the timing feels correct, Gate 41 can take action. Gate 41 is an idea that is waiting for the right timing so that it can be expressed into action.

Affirmations

- My mind is my most creative tool. When I am inspired, I have the ability to hold on to the vision of what I intend in a steadfast and focused way.
- My ability to hold my intention is my greatest creative blessing. I never falter. I never waver. My eye is pure and my vision is clear.
- What is manifest in my outer reality is of no consequence to what I am creating.
- I am grateful for the signs that I am on my way to creating exactly what I intend.

Writing Assignments

1. How is false fantasy keeping you from seeing the truth? Are there circumstance in your life that you need to release in order to create what you truly intend?
2. Are you communicating clearly? Are you listening with intent? Are there places where you need to clarify your intentions to others?
3. Where do you lose your focus? What distracts you from believing you can have what you intend?
4. What can you do to stay true to your vision? What do you need to do to anchor your intentions?

Gate 42: Finishing Things

I Ching: Increase

Astrology: Aries

Biology: Ovaries and testes

Gate 42 is the gate of coming into the middle of a situation or experience and finishing it. Gate 42 can be an excellent project manager or consultant, provided the start-up phase of a project is complete when they enter into it.

Gate 42 (like Gate 53) can feel deeply frustrated when it is not responding to opportunities to finish things. The correct energy for starting will manifest when Gate 42 is waiting to respond to the right experience. With the correct response comes the energy to get things started and finished. Without waiting, there is only frustration and adrenal burnout.

With this energy we can sometimes feel pressure to complete things. Tune in and be sure this is a deliberate action. With clarity, you can create abundance in your life by making room for something new. But first, finish what needs to be finished.

Affirmations

- I embrace all the change that has come before, and I recognize that all endings are new beginnings.
- I open the door for the new and re-dream what is to come.
- I am fully prepared to lay down the physical manifestation of the foundations of what is new and to take the actions necessary to bring what is new into form.

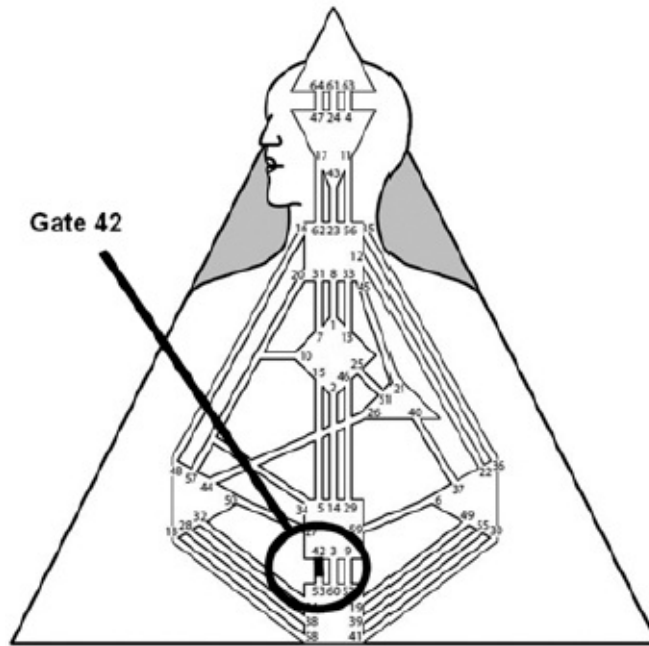

Figure 92: Gate 42

Writing Assignments

1. What final steps do you need to take to release the energy of this first quarter? What doors do you see opening? Closing?
2. What clarity have you gained since the beginning of the year? How has that clarity helped you define what you truly want?
3. What action steps do you need to take to bring this into form?

Gate 43: Insight

I Ching: Breakthrough

Astrology: Scorpio

Biology: Anterior and posterior pituitary glands

The highest expression of this energy is the power to see an alternative to old ways of doing things and to create a new, empowered means to a high-minded end. Gate 43 states that the ends and the means must match. The ends cannot justify the means if the ends are destructive and damaging. It is the gate of the

inner ear and listens internally to what is correct.

Gate 43 must wait for the right opportunity to express its breakthrough. The biggest challenge is to not bend to the pressure to try to articulate before the timing is correct. Without proper timing, recognition, and an invitation to share what it knows, the “breakthrough” of Gate 43 fizzles into nothingness, generating loneliness, rejection, and pain.

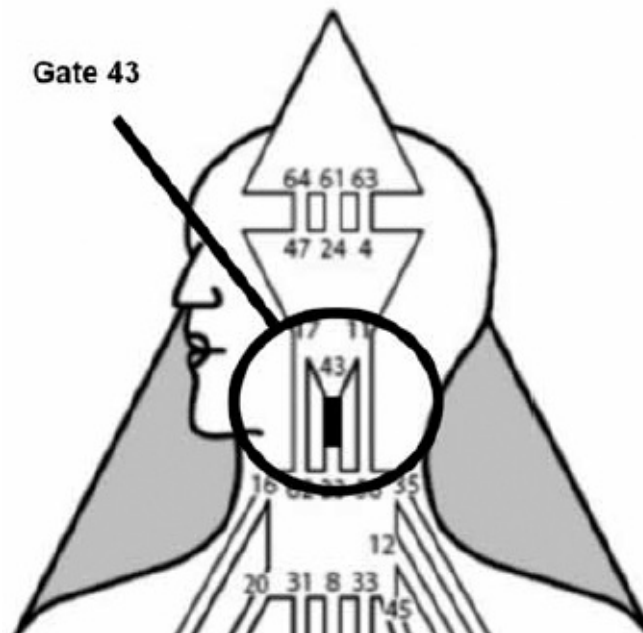

Figure 93: Gate 43

Gate 43 is also one of the gates of aloneness. Gate 43 needs time alone to think and wait. This is crucial for the health of Gate 43.

Affirmations

- I take time to enjoy my thoughts. I allow myself to begin to formulate new ideas and inspirations that can create change in my life and in the lives of others.
- My thoughts and ideas are valuable, and I trust that what I have to share is valuable to the right people.
- I attract the right support, circumstances, and opportunities that align with my new ideas.

Writing Assignment

Take some time to do a “brain dump” of all your current thoughts, ideas, and inspirations. Can you see a pattern of something new emerging? Are you on the cusp of a breakthrough?

Gate 44: Energy

I Ching: Coming to Meet

Astrology: Scorpio

Biology: Spleen and lymphatic system

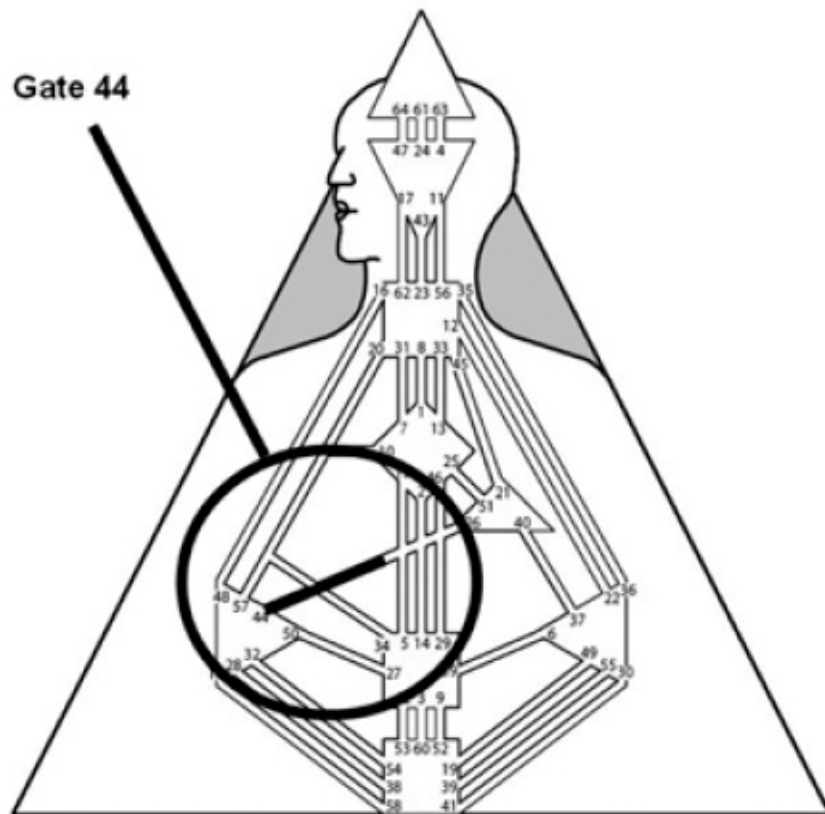

Figure 94: Gate 44

Think of a car sales lot. The greeter welcomes you and shows you around from the moment you set foot on the lot. Maybe she even brings you a nice hot coffee, takes you to a beautiful lounge, and lets you stroll amongst the shiny models parked inside the building while you wait for a salesman. You have just

been primed for the sale. Gate 44 is the greeter.

Gate 44 is part of the energy of sales. It creates the atmosphere that enhances the closing of a sale. Gate 44 makes things “look good.” They create beautiful materials that sell. Many graphic designers and marketers work with this energy.

Gate 44 is also the gate of smell. The intuitive smelling of Gate 44 comes from the ability to “smell” the truth (or not). Gate 44 can smell a “rat” or a “thief.”

Gate 44 is imbued with the energy to “sell” the messages from the past to the tribe. Gate 44 can make a good case when necessary. It contains the intuitive awareness of whether the past is worth repeating or not, and it can tell you when the past is about to repeat itself. The highest expression of Gate 44 is to bring the lessons from the past into the present so that we don't repeat the same mistakes.

Affirmations

- I move confidently into the future, knowing that my past has been my greatest teacher.
- I am not limited by my past, but rather liberated from it, and I realize that now is the most powerful moment of my life.

Writing Assignments

1. Are there places where you limit yourself because of things that have happened to you in the past?
2. Are you in full integrity when it comes to leading or influencing others? Do you walk your talk?
3. Are there places where you need support from others? Imagine your perception of your life from your deathbed. What things would be important to you?
4. What accomplishments would you be most proud of? Is your life today a good reflection of that perspective? Do you need to change your priorities?

Gate 45: The King or Queen

I Ching: Gathering Together
Astrology: Gemini

Biology: Thyroid and parathyroid

Gate 45 is the gate of the king or queen. This is the energy of natural leadership. People with Gate 45 will naturally be recognized as leaders with influence. This is not democratic leadership; this is easy and effortless leadership that has a regal feel to it.

In the energy of this channel, it is Gate 45 that makes the proclamation of what we have or have not. The king or queen can be the great allocator or spender of the resources (though they will struggle without the help of Gate 21). Gate 45 is very tied to its tribe. Often, people with this energy will not make changes easily, especially if it means leaving their people.

Gate 45 in its highest expression can be an energy of great influence. As a regal leader, this gate can inspire the tribe to work or rest, and it determines the work or sacrifices necessary to sustain resources.

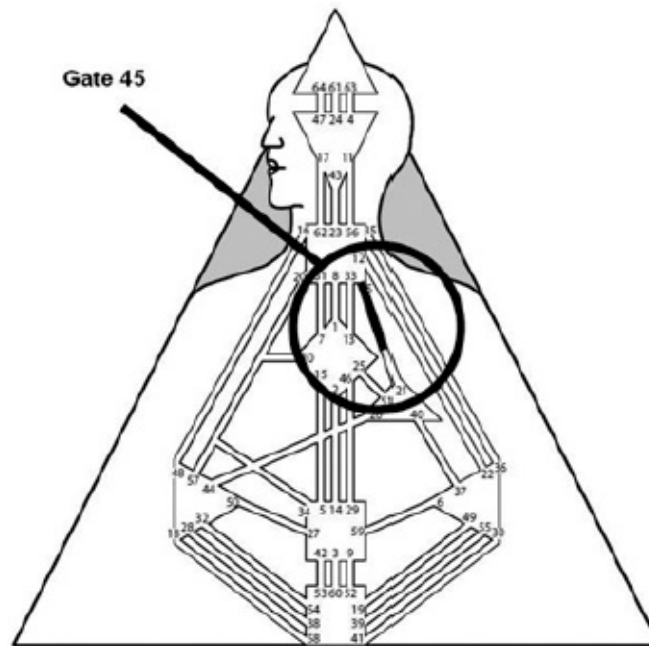

Figure 95: Gate 45

Affirmations

- I gather all the people necessary to support my manifestation in my life.
- I take leadership and honor my role as the king or queen of my creation.
- I assert my power, delegate, manage resources effectively, and act with

benevolence.

Writing Assignments

1. Where in your life do you need to assume a leadership role? How do you feel as a leader? Is it okay for you to be in charge, honor your creation, and speak your truth?
2. What do you need to do to attract the right people into your life to serve your manifestation and creation? Is your mindset aligned with being a team player, or a king or queen?
3. The shadow side of a monarchy is that the king or queen can be controlling and punitive. Where do you need to let go of your creation and allow it to evolve?

Gate 46: Love of Body

I Ching: Pushing Upward

Astrology: Virgo

Biology: Liver

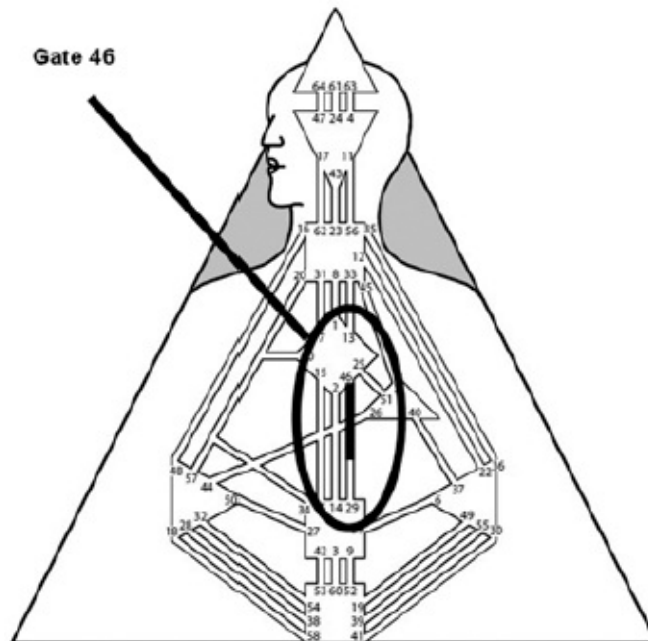

Figure 96: Gate 46

Gate 46 is all about the physical embodiment of love. It understands that the body is a vehicle for the soul and is all about movement and living in the body. It is sensual, graceful, experiential, and grounded. People with this energy are deeply present to the body, and we see a lot of yoga teachers, dancers, and even portrait photographers with this energy.

This gate is not about predicting or forecasting. It is not logical. It is the energy of being and experiencing in the body. It is also about giving the soul expression, and this energy can give way to deeply expressive art and movement. This entire channel is about being alive in a purely sensual way. It yearns to move, longs for expression, and holds dear to the responsibilities of commitment that give life meaning.

If you have this energy, you may have a yearning for physical perfection or work as a healer.

Affirmations

- Physical reality is an expression of my consciousness. I look to my reality to mirror my mindset and my beliefs back to me.
- I am clear, conscious, and awake. I can adjust my mindset to create any physical experience I choose.
- I take guided actions that are in alignment with my beliefs, and I celebrate this gift of being alive in a physical body!

Writing Assignments

1. What is your reality telling you? Are there messages you need to heed?
2. What discourages you? Do you push, or do you allow? What do you need to do to allow rather than think through? Are your intentions and actions an accurate reflection of your true heart's desires?

Gate 47: Realization

I Ching: Oppression

Astrology: Virgo

Biology: Anterior and posterior pituitary glands

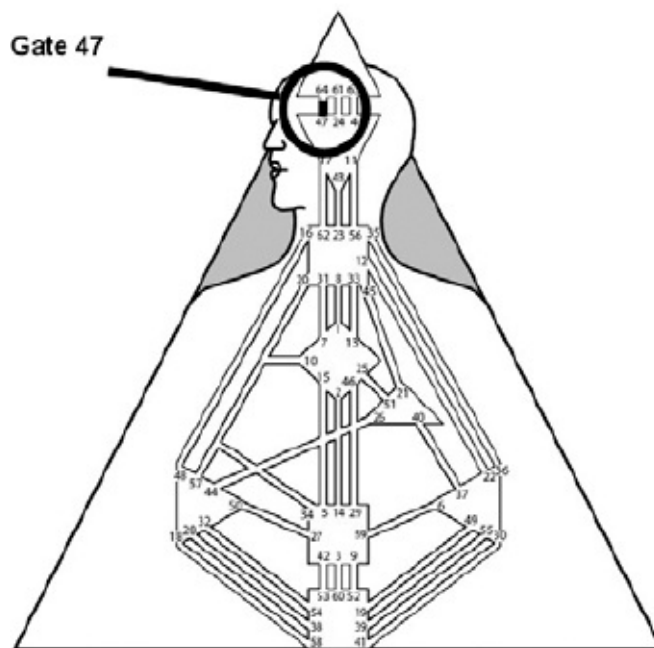

Figure 97: Gate 47

Gate 47 can be referred to as the mindset gate. When it operates with the expectation that the answer to how to do something will come, then it can move forward with confidence that its inspiration will somehow be answered by action, serendipity, and the magic of the Universe. But when Gate 47 gets stuck in trying to figure out how, it runs the risk of quitting before epiphany because the how is not answered. This traps Gate 47 in a mentally oppressive state, and it can come to believe that it doesn't know how, and therefore what it is inspired to do is futile.

The energy of Gate 47 demands leaps of faith, belief in the impossible, and a relaxation of the need to know. Gate 47 has to trust that the answer is coming, and it just needs to wait.

The arrival of the epiphany depends on a person's mindset. If you stay open and expect a solution, then the solution can show up easily. But if your mindset is closed, anxious, or pressured, it's hard for the epiphany to break through the mental chatter. And when it does show up, if your attitude is closed, you might not trust the revealed solution. Mindset is always crucial.

It is very important to address Gate 47, as it can be one of those energies that can profoundly impact you in a harsh way if you don't understand how to work with it. Gate 47 is the gate of "epiphany," the answer to the inspiration of Gate

64. However, unlike Gate 64, it works over time, and when it is uncoupled from Gate 64, it is simply the pressure to figure out how to make something happen.

Affirmations

- I wait with delighted anticipation and marvel and the curious way the Universe manifests my desires.
- I keep my mindset joyful and positive, and I only focus on the end result.

Writing Assignments

1. What is the status of your mindset? Do you need to take care of your thought patterns?
2. What things will you do while you are waiting for your manifestation? What will you do to keep your vibration high while you wait?

Gate 48: Depth

I Ching: The Well
Astrology: Libra
Biology: Spleen and lymphatic system

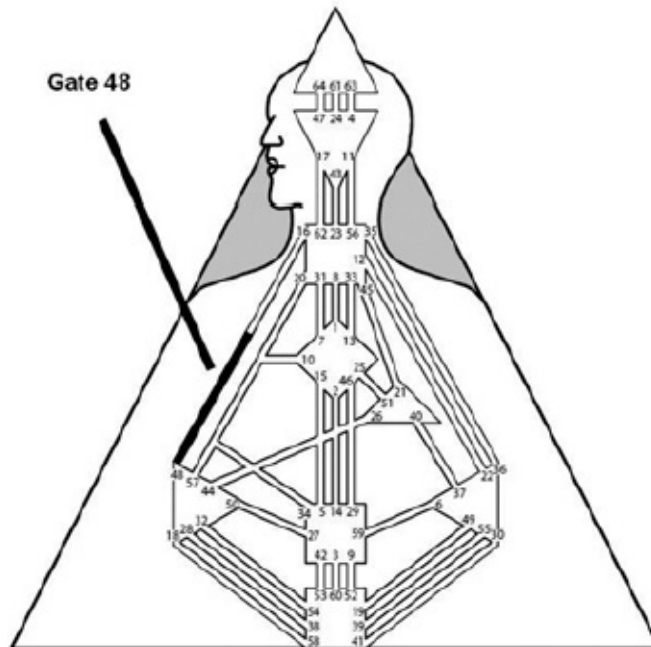

Figure 98: Gate 48

Gate 48 is a splenic fear-based gate. It is afraid that it will never know enough, that it will always be inadequate. The challenge with Gate 48 is to “just do it” even when you are scared. When you push through the moment, the fear dissipates, and Gate 48 can then begin to collect data over time to prove that it does indeed know enough. The fear of Gate 48 feels very real, even though others observing it may find it amusing. Usually people with Gate 48 are overprepared for everything.

This is also the gate of taste, both visual and culinary. People with Gate 48 may have an intuitive understanding of beauty and design and long for things to be designed well. Or they may have sophisticated palates and desire rich culinary experiences. On the other side, they might be very picky eaters—especially if they are children.

Affirmations

- I trust that the skills I need will be expressed through me when I am ready.
- I study. I learn. I know that my knowledge will be beautifully expressed when the time and the circumstances are correct.
- I trust Divine Order.
- I am perfectly prepared when the opportunity arises, and I honor myself for the depth of my knowledge.

Writing Assignments

1. What information do you need to deepen your knowledge base? What do you need to learn?
2. Do you have the skills necessary to bring forth what you desire? If not, what do you need to master?

Gate 49: Principles

I Ching: Revolution

Astrology: Aquarius

Biology: Kidneys and pancreas

- Change is a necessary part of growth and evolution.
- I intentionally push into the new revolution of my life with courage and clarity.
- I trust that my steps toward change are crucial to creating what I intend for my life, and I am grateful for all that I have learned and all that I am about to receive.

Writing Assignments

1. Are your relationships and agreements working the way you intend? If not, what kinds of conversations do you need to have to create alignment?
2. This is a week of radical transformation. What do you need to do to maintain a core or center in your world?
3. What is the status of your connection to Source? Do you need to deepen your connection? If so, what will you do?
4. What kinds of changes need to be made in your business or work agreements? What do you need to do to prepare for these changes?

Gate 50: Values

I Ching: The Cauldron

Astrology: Libra/Scorpio

Biology: Spleen and lymphatic system

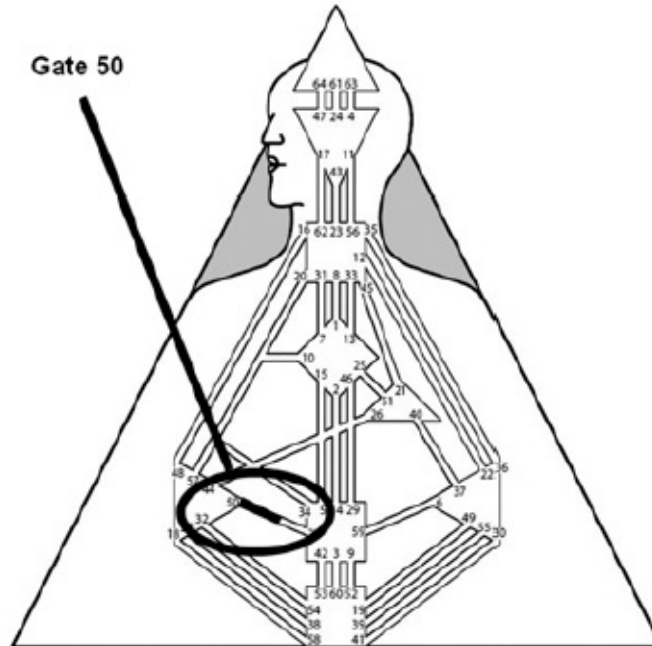

Figure 100: Gate 50

Values and laws are stored in Gate 50. Gate 50, like its counterpart, Gate 6, has the ability to penetrate other people's auras. When you are with Gate 50, you will obey the rules and values of the tribe. Even if you are deeply individual, the energy of Gate 50 will force you energetically to be tribal. You will care and support even if it isn't inherent in your design.

Gate 50 is a love gate. This energy can be soft or rigid, but it will always be influential. The values of the tribe are transmitted with love. It may not always feel loving, but a smack on the behind in response to breaking a rule can be loving. And the intention is to bind the tribe together. Gate 50 will sacrifice its individual needs to take care of others. There is no mind here. It is pure instinct. People with Gate 50 often have a long history of taking care of others, including some who perhaps they should not be caring for.

Caring with Gate 50 is instinctual and reflexive. The Sacral response will protect a person with Gate 50 from overnurturing. Gate 50 with an open Emotional Solar Plexus is easily manipulated with guilt. It is crucial that a person with Gate 50 rely on the Sacral to protect them from burning themselves out taking care of others.

Gate 50 is also a fear gate. It is splenic, intuitive, and “in the now.” The dark expression of this energy can be a fear of failing one's responsibilities. The deepest fear of Gate 50 is the fear of failing to take good care of its loved ones.

Affirmations

- I establish the rules for my reality.
- I take care and nourish myself so that I may take care and nourish others.
- Everything I do for others I do for myself first in order to sustain my energy and power.
- I rule with self-love and then love freely.

Writing Assignments

1. What new rules do you need to play by? Do you need to create new rules in your relationships, your business, for your health, wealth, and welfare?
2. Do you love yourself? Do you need to nurture yourself more? Do you have the strength and foundation to love freely? Do you feel safe in love?

Gate 51: Shock

I Ching: The Arousing
Astrology: Aries
Biology: Thymus

Gate 51 is one of the most interesting gates in the Human Design system. It is very competitive or projects competitive energy and is the shock aspect of initiation. Many people with this gate will be shocking just for fun! Of course, this energy is radiated, so people with Gate 51 receive amplified shocking experiences. Gate 51 can have many shocking experiences that are initiating forces in their lives. Ra Uru Hu had Gate 51, and he was “shocked” into receiving the Human Design information. People with shock in their charts often have to have very intense, life-changing experiences before they can move into the love of Spirit. Many people with this gate have had neardeath experiences or some other kind of amazing story of shock and survival.

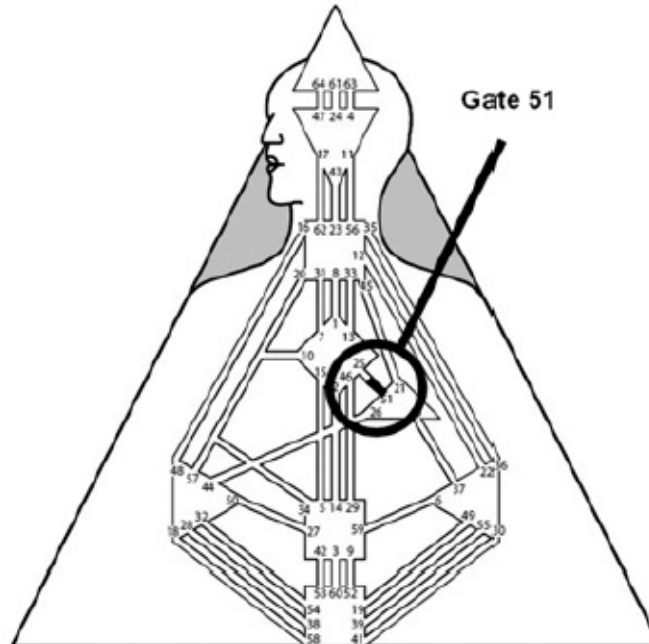

Figure 101: Gate 51

As much as we resist shock, shock has a powerful role in starting things. Shock is designed to shake things up. In response to shock, we change. If we don't change, we can become bitter. Certainly, you can expect to have new spiritual or mystical understanding when you have this energy.

Affirmations

- I have the inner strength to deflect all outer shock.
- I am the manifestation of Spirit in form. I am courageous, steadfast, and open to the expansion of Spirit within me.
- My faith and courage inspire and initiate others.
- My vibration is high, and I lift others up with the truth of Spirit within me.
- I use all of my life experiences as catalysts to help me grow and evolve.

Writing Assignment

What lessons have you learned from shock? How have you transformed shock into strength? How has shock initiated you into the love of Spirit?

Gate 52: Stillness

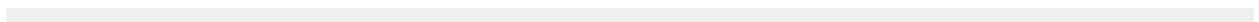

I Ching: Keeping Still Mountain
Astrology: Cancer
Biology: Adrenal glands

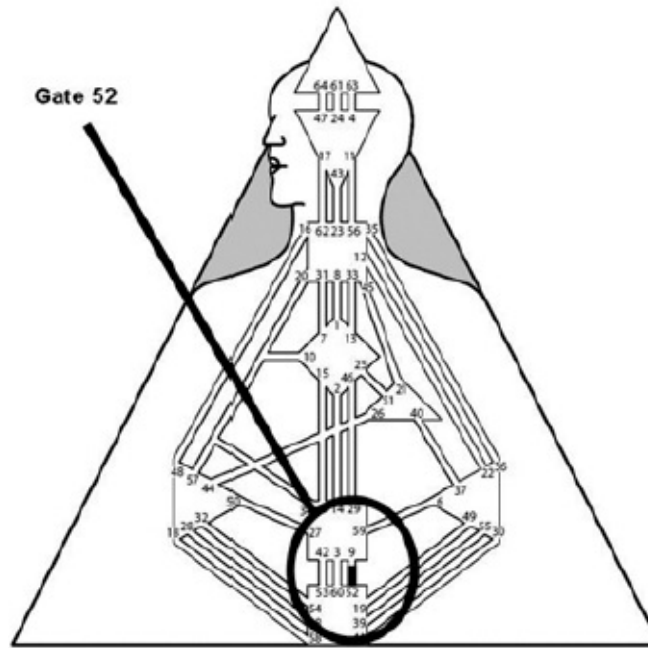

Figure 102: Gate 52

The energy of this gate is the potential to sit in concentration, very still and very quietly, for long periods of time. Sometimes you might call this gate the couch potato gate.

The irony of this gate is that without its harmonic, this is just sitting still without focus. Gate 52 makes for great wildlife photographers. You can sit in the blind for hours just watching and waiting, as long as you don't get distracted.

This is a highly creative energy, one that empowers you to concentrate on the goal, hold your gaze, wait in stillness until the right time, and then, and only then, take right actions.

Affirmations

- The stillness of my concentration allows patterns and order to be revealed to me.

- My understanding of this order gives me the power to continue to create effectively.
- The stillness of my concentration is the source of my power.

Writing Assignments

1. What do you need to do to create stillness in your life?
2. In the stillness, what questions do you have? What patterns are being revealed to you? How deeply do you feel the alignment of Divine Order?
3. Define your power. Where are you powerful? Do you feel good being powerful? If not, why and what stops you from your power?
4. Do you need to amplify your power? If so, how?

Gate 53: Starting Things

I Ching: Development
 Astrology: Cancer
 Biology: Adrenal glands

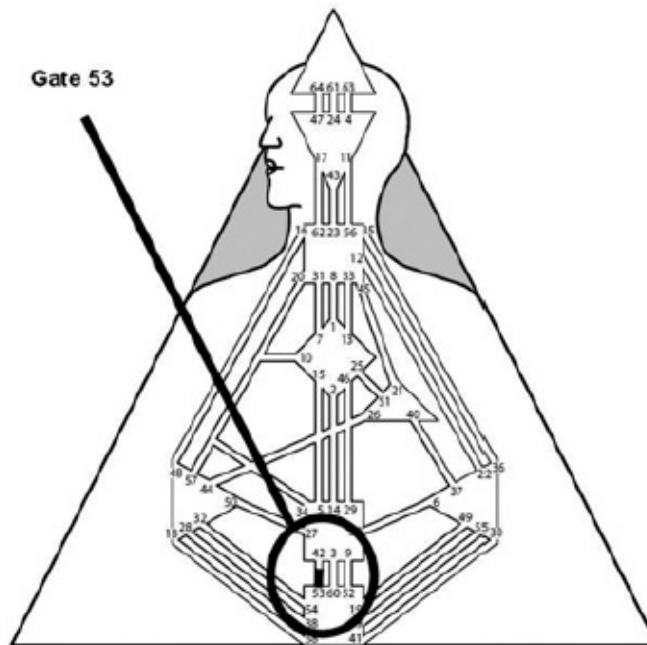

Figure 103: Gate 53

Gate 53 contains the energy for getting things started. When responding, this channel is always starting the right experience or bringing the energy of starting to others. Gate 53 is full of good intentions. Gate 53 is notorious for starting things and struggling to get them finished. It is normal for this gate to have all kinds of unfinished projects lying around the house.

When Gate 53 is forced to finish something, it can be a long and arduous process. The energy for finishing just isn't there. But when Gate 53 responds, it starts the right things and attracts to it the right people to finish the project. This gate makes a great initiator or project start-up manager. Never place Gate 53 in project management, though.

Remember that the energy for getting started is far away from the Throat Center. That means there is still a lot of energy required for completion and expression. This is an initiating energy. A pulse for a new beginning.

When the impulse to begin is correct and acted on correctly, then all of the energies, serendipities, and opportunities will magically unfold to bring your new beginning to its full expression in your life.

Affirmations

- I wait and start things according to my strategy.
- I allow for the energy of new beginnings and trust that when I live my strategy, all the key pieces to complete my creative process will magically align.

Writing Assignment

Stay tuned this week to the energy of new beginnings and starting things. Allow the ideas, revelations, inspirations, and spurts of initiation energy to rev up your engines, but wait according to your strategy to jump in! Make a list of your new ideas or your renewed inspirations.

Gate 54: Drive

I Ching: The Marrying Maiden
Astrology: Capricorn
Biology: Adrenal glands

Gate 54 is the seat of ambition. It will work hard to fulfill its dreams and to get

recognized. The irony is that there is not actually much energy here. As this gate works to provide and is based in Will energy, Gate 54 will work and work and work without a rest until it collapses.

The projected aspect of Gate 54 can be quite bitter, but too busy working to do anything about it.

The high side of Gate 54 can be quite beautiful. When recognized, it is the gate of enlightenment. The dreams of Gate 54, when supported and recognized, can go into the realm of unlimited possibility. Of course, even with these kinds of dreams, it must be recognized or else they are just dreams. With recognition, Gate 54 can do big things. Gate 54 can be an initiating force in any business. This is the chief dreamer of any operation.

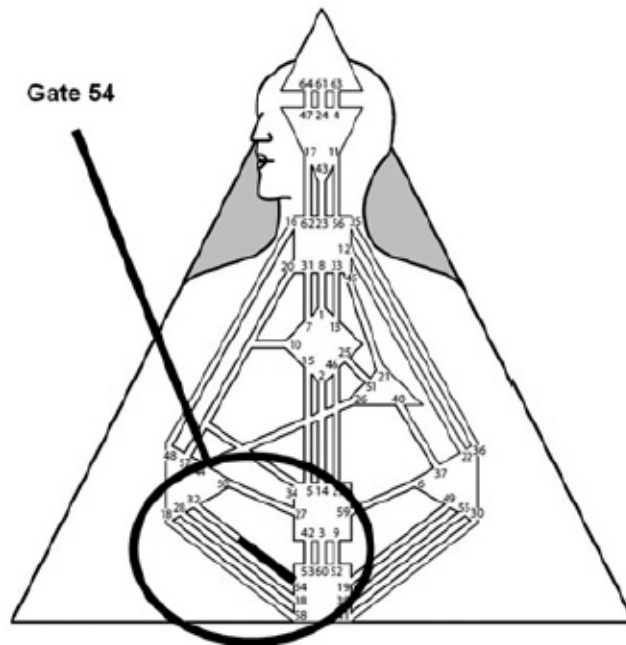

Figure 104: Gate 54

Affirmations

- I am clear. I am focused. I am ready to do whatever it takes to make my dreams come true.
- I know that my clarity married with my aligned actions are the perfect energies necessary to create miracles in my world.
- I am seen, heard, and recognized for what I have to offer, and the Universe perfectly conspires with me to make my dreams come true.

Writing Assignment

What actions do you need to take to show yourself and the Universe that you are ready to move toward your dreams?

Gate 55: Spirit

I Ching: Abundance

Astrology: Pisces

Biology: Kidneys and pancreas

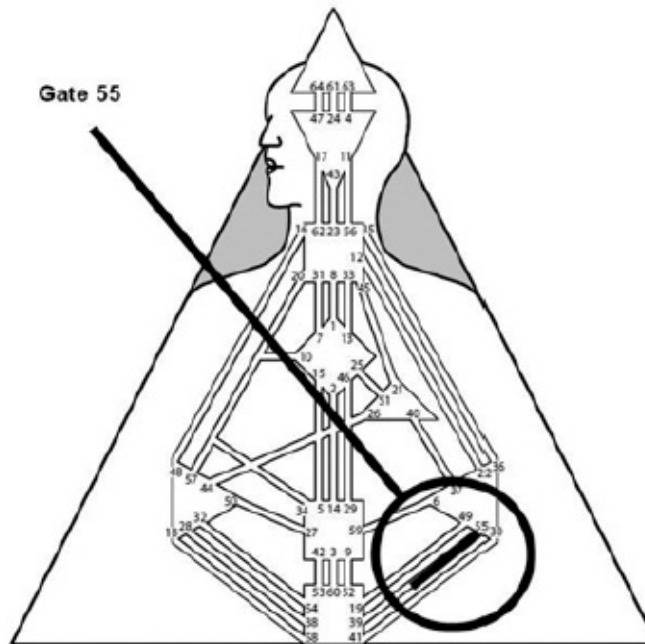

Figure 105: Gate 55

Gate 55 is the gate of abundance in Spirit. It is a beautiful, powerful, and potentially world-changing energy.

In its highest expression, this is the recognition that the infinite abundance of life is available. Our consciousness and awareness of Spirit as the source of abundance in our lives can instantly shift us from a condition of lack to a condition of abundance. It's just a matter of changing perspectives.

But this is an energy that we often have to grow into. The energy for money and physical resources is deeply tied to the energy for working in the Sacral or

willpower in the Will Center. We are deeply conditioned to believe that the only way to create abundance and resources in life is through sheer will and hard work. Gate 55 presents us with the spiritual question of how much we are willing to trust in the abundant nature of Spirit. Do we have the courage to let go and let God?

For those who have this energy in their charts, this can be a lifelong journey. It takes courage to let go of traditional action and to trust in Spirit as your source of support. If you have this energy, you have to sometimes wait for the right timing or energy to take action. That also means that sometimes you have to act in a way that is seemingly counterintuitive and deal with the struggles in faith that can happen when you eschew the traditional path of working hard to make money.

Ultimately, this energy teaches us that if we don't have enough pie, we don't have to struggle to figure out how to slice it. We can just bake more pies. The nature of life is limitlessly abundant. The consciousness of Spirit as Source is the most powerful awareness necessary to push the collective consciousness into creating the possibility for abundance for everyone on a global level.

Affirmations

- I am aware of the abundance of Spirit within me, and I know that when I am focused on this abundance that all my desires are fulfilled and it is impossible to experience lack or need.
- I am completely supported and fulfilled by this awareness.
- By letting go and letting God, I allow abundance in all aspects of my life to manifest fully.
- Abundance is my birthright and my natural state.

Writing Assignments

1. What beliefs do you have about being fully supported and abundant? Do you need to align these beliefs with what you know is truth? What do you need to do to release worries and fears about abundance?
2. What does being aware of the abundance of Spirit within feel like? What does it look like? How would being constantly aware of this fulfilling energy change your life? What do you need to do to be ready for this level of faith and trust?

Gate 56: The Storyteller

I Ching: The Wanderer
Astrology: Cancer/Leo
Biology: Thyroid and parathyroid

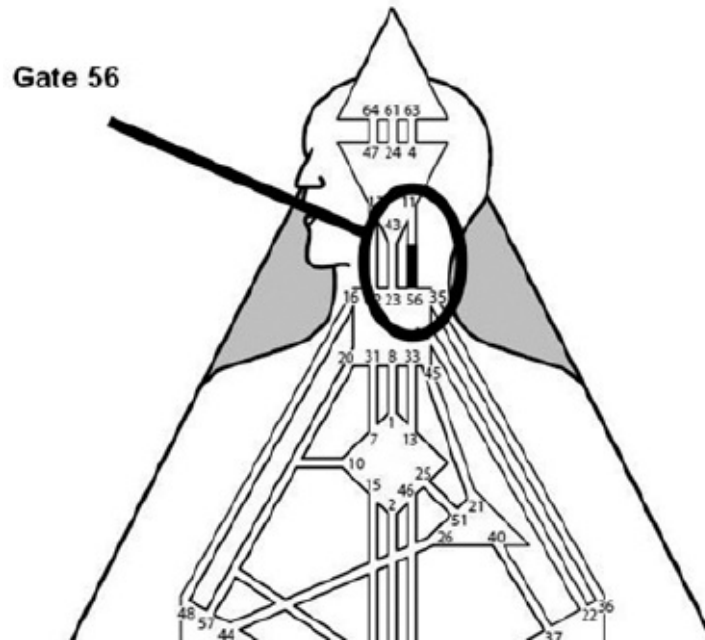

Figure 106: Gate 56

Gate 56 is one of the gifted-teaching gates. Gate 56 can be a great teacher who can effectively use metaphors to teach and share. Gate 56 can share the stories that help humanity understand its experience on the planet.

While Gate 56 can be a gifted storyteller, it is crucial for people with this energy to remember that their stories are heard and remembered best when people ask for the story. A nonmotorized Throat or an undefined Throat with Gate 56 may often be a person who is constantly telling stories and can even push people away with too much storytelling. When Gate 56 is not waiting for invitations or recognition to share, they can bore people with their potentially captivating story and feel hurt that no one seems to listen.

Affirmations

- I wait to share my ideas and stories with the right people who honor my inspiration and experience.
- My story is an important part of the human experience, and I honor my experience by waiting for the right circumstances.
- My words and my dreams are valuable.

Writing Assignment

Allow your imagination and playfulness to show you all the possibilities of how your dreams may manifest. Allow yourself to stay open to limitless possibilities, and practice telling yourself stories about how you dream of your life being.

Gate 57: Intuition

I Ching: The Gentle
 Astrology: Libra
 Biology: Spleen and lymphatic system

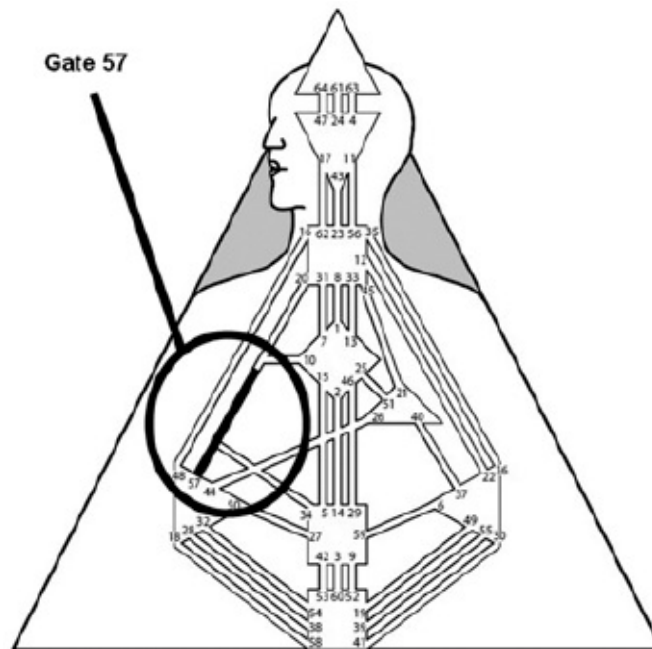

Figure 107: Gate 57

Gate 57 is the most intuitive gate in the Human Design system. In the traditional

I Ching, the fifty-seventh hexagram is the gentle wind that parts the clouds so the sun can shine through. The penetrating intuition of Gate 57 allows the truth to be revealed. It is clear and in the now. Sometimes we call Gate 57 the gate of clarity.

Ironically, in spite of its penetrating capacity for clarity, Gate 57 on its own can be a very uncertain and unclear energy. Most people question their intuition. It is not logical. The intuition of Gate 57 is in the now, and the now changes. What is truth in one moment may not be truth in another.

People who have Gate 57 often struggle with trusting themselves and their intuition. Living your Human Design strategy can resolve this dilemma. The strategy can bypass the mental aspects of indecisiveness in Gate 57 and allow the person to enjoy the benefits of their intuition instead of wrestling with self-doubt.

People with Gate 57 are endowed with deep psychic abilities. It helps to see what else is in the chart to help you identify just how psychic abilities show up.

Gate 57 is a fear gate rooted in the Spleen. Gate 57 fears the future. This can also be some of the root cause of the lack of clarity in Gate 57. When Gate 57 sees a future that is potentially unclear or frightening, it can be paralyzed. As with all splenic fears, pushing through the fear makes the fear short-lived. But not pushing through can leave a person stuck in fear.

Affirmations

- I trust myself.
- I trust my intuition.
- I trust the future.

Writing Assignments

1. What does your intuition feel like? How do you receive intuitive awareness? Make a list of previous events when you trusted your intuition and things worked out well.
2. Are there any intuitive hunches you are receiving right now that need attention?
3. What do you need to do to deepen your intuitive awareness?

Gate 58: Joy

I Ching: Joy
Astrology: Capricorn
Biology: Adrenal glands

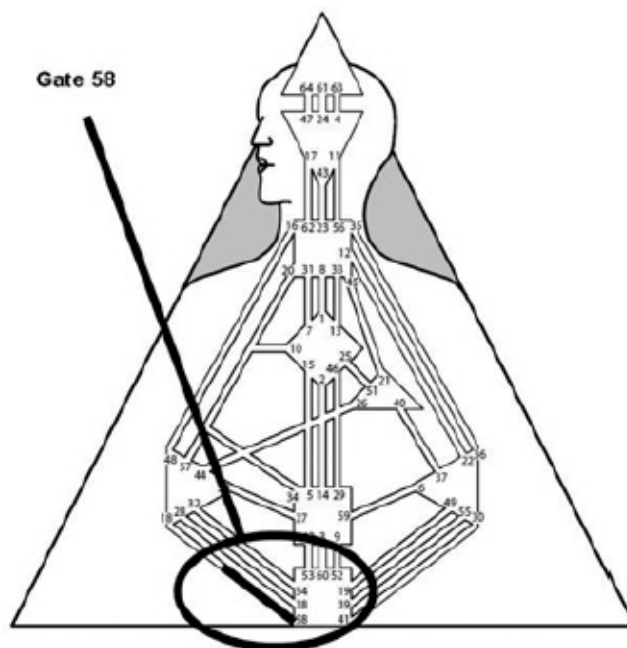

Figure 108: Gate 58

Gate 58 is the energy for the joy of life. People with this gate always have a smile on their face if they live their strategy. These people intuitively understand joy and tend not to take things too seriously.

However, if they are not living their strategy, people with Gate 58 can take a big beating in their joy of life. This is a dual system, after all. People with Gate 58 can be some of the most bitter people on the planet if they understand the potential for joy but are not able to experience it.

The joy can be restored by living strategy and waiting for the right timing for correction. The ultimate beauty of this energy is that it stems from the energy of mastery and correction. Gate 58 can use all of the critical energy in the Logic Circuit to help people discover joy.

Affirmation

- I am grateful for everything that I am, everything that I have, and everything that I have experienced.
- I allow joy to permeate every cell of my being, and I stand in awe of all my blessings.
- I relax and know that the shower of blessings that is my life is part of my divine heritage, and I relax knowing that an endless stream of good flows toward me.

Writing Assignment

Make a list of everything you are grateful for. Take a few minutes to really stay in that place of blissful appreciation every day.

Gate 59: Sexuality

I Ching: Dispersion
 Astrology: Virgo
 Biology: Ovaries and testes

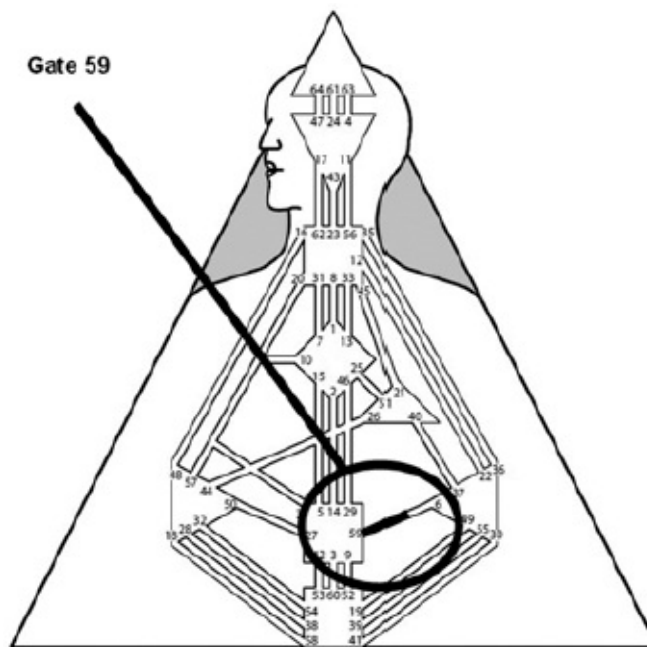

Figure 109: Gate 59

Gate 59 is the gate of seduction. This is pure life force energy, the energy for sexuality or not.

People with Gate 59 try to get to the bottom of intimacy, but the investigation may be theoretical. Gate 59 seeks to master intimacy with investigation. They may know a lot about intimacy, but none of their knowledge may be experiential.

Conversely, Gate 59 may not think that much about intimacy at all, and may need others to bring it to their awareness. Many with Gate 59 feel that they need to have a solid understanding of their partner and relationship before they can commit themselves to intimacy. Because of this, Gate 59 prefers to be romantically involved with someone who is their best friend. True, deep intimacy for Gate 59 is most often found with their soul mate.

Gate 59 also enjoys the game of seducing and being seduced by their partner. However, it may take some time for Gate 59 to commit themselves wholeheartedly to another.

Affirmations

- I am present to love and wait to be called out into intimacy.
- I need space and freedom in my relationships. I need time to know that my love is real. It deepens my desire for connection and intimacy.
- I honor the friendship that is the foundation of my love. My love needs to be my best friend.
- I wait for clarity and enter into my relationships with great deliberation.
- Love is fun and seductive for me, and I enjoy the thrill of seducing my partner (and being seduced).

Writing Assignments

1. What avenues of impact would best serve you, your intentions, and your business?
2. What is the next step in creating your intentions and your dreams?
3. Where do you need to get to work to be ready for things to manifest?

Gate 60: Acceptance

I Ching: Limitation

Astrology: Capricorn/Aquarius

Biology: Adrenal glands

Gate 60 is the energy for the old or established genetic energy. This is the place in the chart where “old” genetic energy meets up with “new” genetic information to create mutation. Gate 60 is conservative and seeks to hold on to what is known to work before it makes change. Gate 60 seeks to evolve, and people with this energy are often wanting to make change and experience personal growth that is careful and deliberate. This is not crazy change for change's sake. This is deliberate and practical evolution that also accepts the limitations of change and makes the best of it.

Affirmations

- I am an unlimited child of the Universe. If I receive an inspiration, I trust and know that the ability for me to bring that inspiration forth into form is mine.
- Inspiration and manifestation happen simultaneously. My only job is to breath, relax, trust, and know that all is in Divine Order.
- It is my job to pay attention to the messages the Universe is sends me and to simply follow my strategy. I don't need to know how my inspirations will manifest.
- I release all resistance and trust that I am always in the right place, at the right time, doing the right thing with the right people.

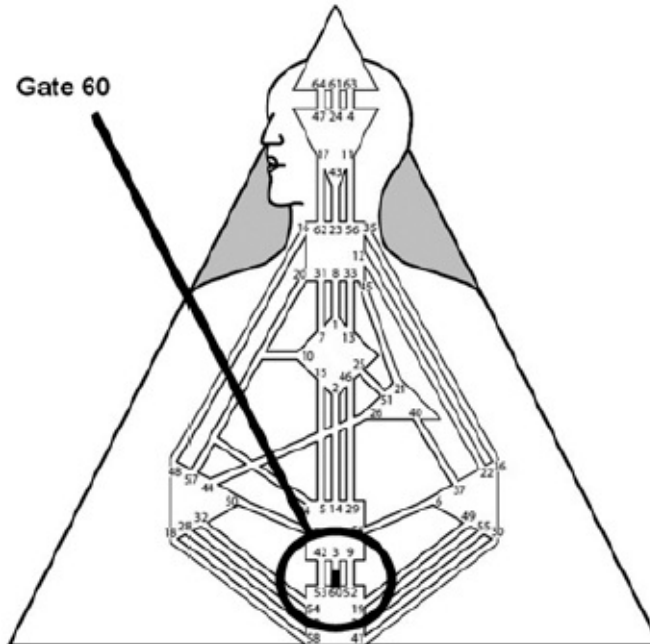

Figure 110: Gate 60

Writing Assignments

1. Do you struggle when you don't know how something is going to happen? How does this limit your ability to create?
2. Are there circumstances or creations that you stop yourself from believing you can receive because you are stuck in the how?
3. Where are you experiencing resistance in your life? What are you resisting? Why?
4. What can you do to create more allowing and more ease in your life?

Gate 61: Mystery

I Ching: Inner Truth
 Astrology: Capricorn
 Biology: Pineal gland

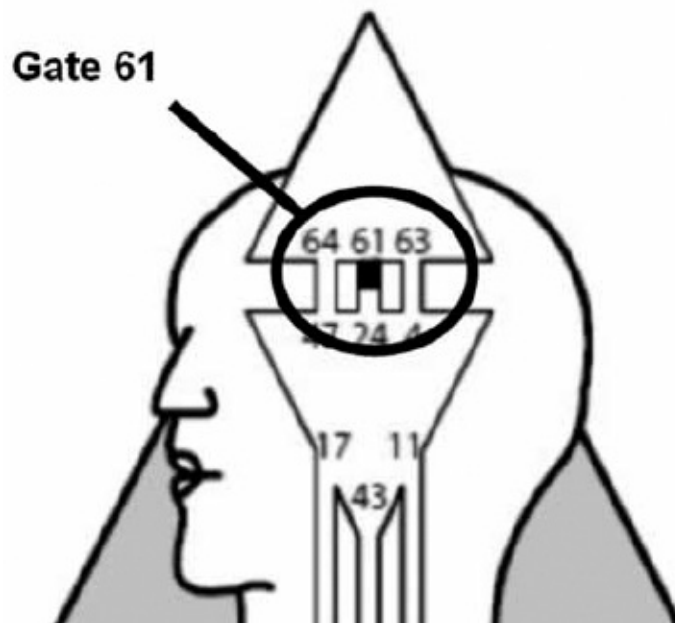

Figure 111: Gate 61

Gate 61 is the initiating sequence to mutative thinking and has the task of transmitting its knowingness without the benefit of logic. Gate 61 knows, period. The end. And if you try to get Gate 61 to explain how it knows, you're missing the point. Gate 61 reaches out to know the unknowable. It contains the energy for discovering or thinking about mystery and even the occult. But without an invitation to express what it knows, we just think it is a bit strange.

The madness of Gate 61 is rooted in the desire to know why and the need to wait for clarity. The knowingness of this gate can often run ahead of itself, knowing what's ahead without knowing the pieces in between. It can skip steps and move to a bigger awareness without acknowledging the places in between that could tie it all together. Gate 61 has to wait to know more, and if they are not honoring the invitation of life to simply enjoy thinking in the meantime, they can go crazy trying to understand more.

Gate 61 has to wait for right timing to know whether what they know is of value. An important mantra for Gate 61 is: "Why ask why? Because it's fun to think." Remember that thinking is often done here simply for the sake of thinking.

Of course, this is mutative thinking, so it's bound to be different. The key to adaption in mutation is waiting for the right time, and, in this case, the right people, to invite Gate 61 to share what it knows. It is crucial for this gate to

guard what it knows until someone asks for insight.

Affirmations

- In the stillness I surrender to the great mystery of life and the Divine.
- I allow divine inspiration to wash over me, and I listen with great attention and appreciation.
- I trust that I receive the perfect inspiration and simply let the inspiration flow to me.
- I am grateful.

Writing Assignment

Do you feel aligned with something bigger than yourself? What do you need to do deepen your connection with Source? Do you need to create a routine in your daily practice to stay centered and connected?

Gate 62: Details

I Ching: The Preponderance of the Small
Astrology: Cancer
Biology: Thyroid and parathyroid

This is the energy for details, the small details that keep the momentum of opinions flowing toward energy. Gate 62 asks, “What if we did it like this? What if we put this over here, and place all the files in this basket? Then would we be able to create an organizational pattern?” Even if they don't look organized, they know where everything is.

This is the gate of the computer programmer or the professional organizer. Gate 62 always has a practical experiment going. This is the energy for creating the structure and application of the experiment. Gate 62 determines the statistical tests to be done, what equipment to use, and how to log the data. It is the energy for articulating plans and ideas in an organized, logical manner. It connects the energy from the realm of possibility to the Throat Center and creates, through articulation, the possibility of manifestation.

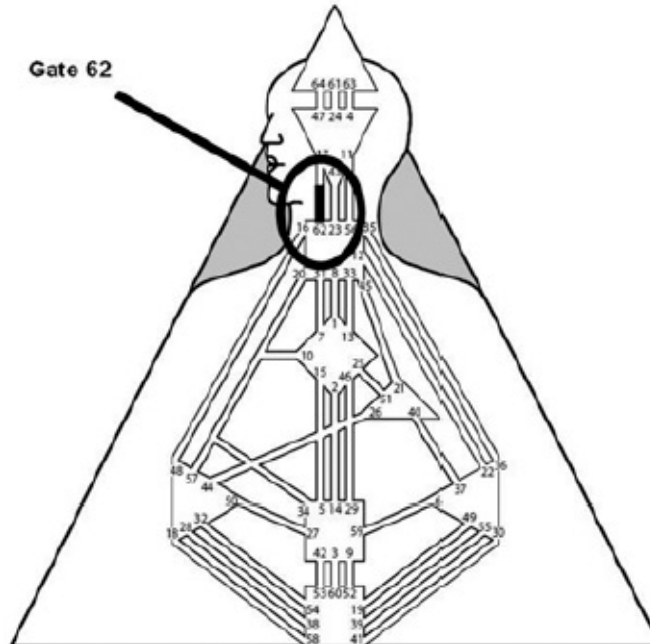

Figure 112: Gate 62

Affirmations

- I use my words carefully. My words generate form for my dreams and ideas.
- My thoughts are clear and organized, and I find and speak the truth with courage and consistency.
- I am organized and filled with practical solutions for others. I patiently wait for them to ask for my insight.

Writing Assignment

Time to revisit our vision and renew our commitment in words to our dreams. Write out your dream in words. It is the power of pure possibility expressed in words that creates things.

Gate 63: Doubt

I Ching: After Completion
 Astrology: Pisces
 Biology: Pineal gland

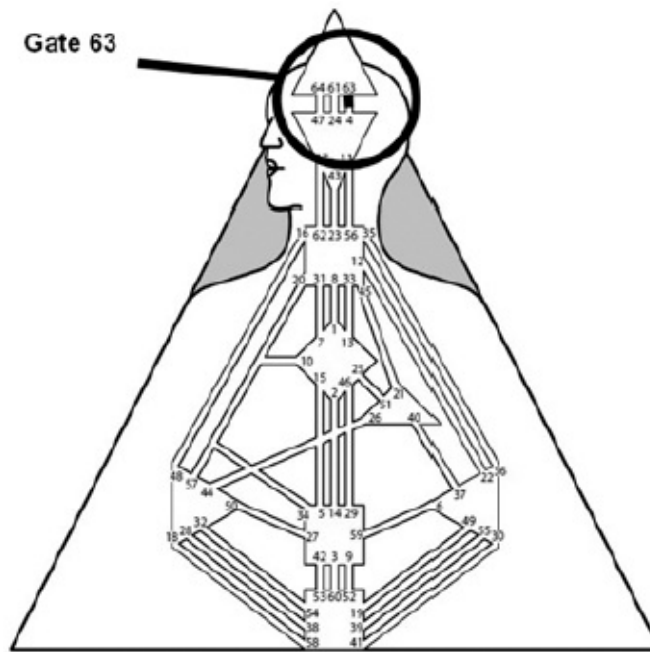

Figure 113: Gate 63

Gate 63 contains the inspiration for logic. Gate 63 on its own is full of doubt and suspicion, followed by a demand for proof.

This particular gate can have some interesting challenges built into it. Doubt and suspicions are energies. And like all energies in the Human Design chart, they flow, almost reflexively. People with Gate 63 will have a tendency to be doubtful and suspicious of everything, including their own insights and abilities.

Although this is a valuable process for logic, it can be a difficult personal energy. The doubt and suspicion expressed by Gate 63 is intended to be pointed toward information, not toward yourself or others.

When you see Gate 63 combined with Gate 48 and an open Head and Ajna, you have a potent combination for mental paralysis and deep interpersonal inadequacy. Remember, these are collective energies and not at all intended to be expressed toward the self. The purpose of these energies is to correct the expression of information in the world.

The other aspect of this is recognizing that the doubt in the head is just a thought or idea and not necessarily true. It takes time to justify suspicion and doubt. You need proof. When you are out in the world freely expressing doubt and suspicion, is it usually met with resistance. Doubt is better left in your head

until you have the data and you are asked to share.

Affirmation

- I trust myself and the Divine.
- I trust that there is perfection in experimentation.
- I trust my insight and knowingness. I am discerning, but not doubtful.
- I know that all questions have answers. I trust in the elegant solution and know that the answer will be mine in time and all is well.

Writing Assignments

1. What experiences have you had that have caused you to doubt yourself?
2. What experiences have you had that have shown you that your inner knowingness is correct? What are your gifts, your strengths, and your talents? Where have you demonstrated mastery, and what do you need to do to release self-doubt?
3. Do you trust in Divine Order? Do you think everything has a purpose?
4. What mistakes have you witnessed that ultimately created a path to perfection and mastery?
5. What do you need to do to integrate mistakes as a crucial part of mastery?

Gate 64: Confusion

I Ching: Before Completion

Astrology: Virgo

Biology: Pineal gland

Gate 64 is the gate of the left eye and the right hemisphere of the brain. Information and inspiration comes in large chunks or “downloads.” An entire idea is formed seemingly out of thin air, without the sequential gifts of logic. One moment there is nothing, the next moment there is a big idea.

The confusion and pressure of this gate manifests when you try to force a right-brained inspiration into a linear sequence. It's difficult to implement the “how it's going to happen” part of this kind of thinking if the timing is not right. Gate 64 has its own timing, and you cannot force a manifestation or even understanding until the timing is right.

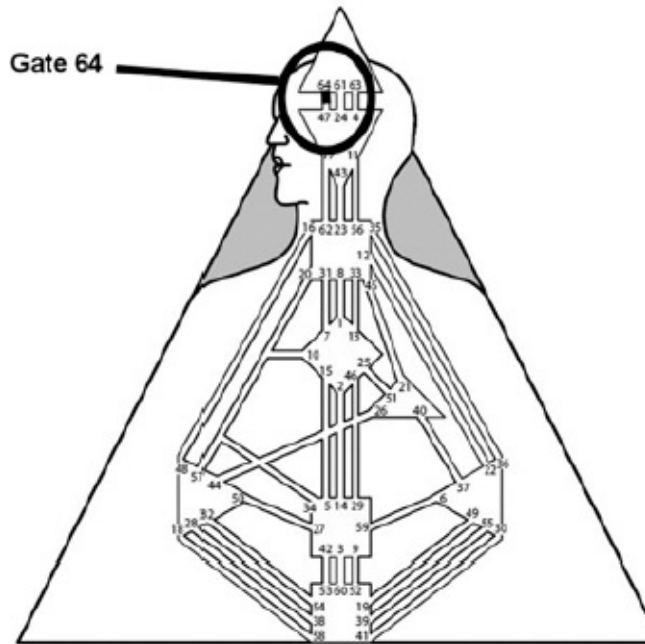

Figure 114: Gate 64

The real challenge of this gate is making peace with not knowing how things are going to happen. We live in a world that is deeply conditioned by logic and the left hemisphere. We are told that if we are inspired, it doesn't “count” unless we can also figure out how it's going to come into form. So, Gate 64 learns to either guess at the details or be quiet.

There are strategies to help this way of thinking. Gate 64 thinks visually, and visual tools can help with learning and expression. A child with Gate 64 can learn to write logical and linear reports if given index cards to write their ideas on. The child can then visually organize the ideas until the flow feels correct.

Gate 64 is often confusing to others. When Gate 64 speaks, it often has to speak “around and around” an idea until it hits upon some sort of sense. This can be confusing to those who are trying to follow the circles. Gate 64 is often busy trying to make big ideas happen. In children, these can be the kids who want to create “impossible” science experiments for the science fair and often need help breaking their big idea into smaller, more manageable tasks. Gate 64 can make peace with itself when it realizes that clarity comes in time in the form of epiphany. All Gate 64 has to do is wait, and the answer will come.

As the representative energy of the right hemisphere, Gate 64 is also the gate of connection to super-consciousness. Greater understanding and more esoteric

awarenesses can trigger inspiration in Gate 64. It's not unusual to be inspired by a force that seems bigger than you and divinely sourced.

Affirmations

- I pay attention to inspiration and know that when I wait with curious anticipation to see how my inspiration manifests, amazing things happen!
- I am delighted and curious to see what the Universe brings.

Writing Assignments

1. What are your big dreams?
2. Do you trust that they will manifest?
3. What strategies do you have to stay in joy while you wait for your manifestation?



The sixty-four gates can give you powerful insight into who you are, what drives you, and where you might consciously grow and evolve. When working with these energies, remember that there is always the possibility to use any of these sixty-four energies in a way that supports and empowers you.

It's important to remember, as you go through these gates, that everyone has all of the gates. If you have a gate defined, that means you experience this energy consistently. If you have a gate open, you still experience this energy, just in a more variable way.

You may have found that as you went through these gates, some of them felt very relevant to you, even if you didn't have them defined. We are all influenced by the energies of the people around us. Your loved ones and family may carry energies that you don't have personally but which ultimately create themes in your relationships. I encourage you to do the exercises for all the gates. These energies truly are part of the energetic archetype of what it means to be human.

Chapter 6

The Major Circuits

Much like the electrical wiring in your house or on a circuit board in your computer, the body graph has lines of related energy that operate together called “circuits.” These circuits reveal the mechanics of the evolution of humanity in the past and play an important role in continuing the evolution of humanity in the future. Through learning about circuits, you will also learn another layer of information about yourself, your purpose, and your place in the puzzle of humanity.

There are three major circuits: the Individual, the Tribal, and the Collective. Each of these circuits plays a unique role in sharing information, values, and survival strategies, and they all work in conjunction to further humanity.

The Individual Circuit is all about initiating change on the individual level. When one person gets a new idea or discovers a new way to do something, this energy is represented in the Individual Circuit. The energy here varies from the norm; it mutates, and consequently it inspires change in others.

When the individual discovers a new perspective or a different way of doing things, they bring this change to the tribe, represented by the Tribal Circuit. Members of the tribe then spread the change to the greater whole of humanity, or the Collective Circuit.

Imagine a small tribe of people living on the Great Plains. It's springtime, and the tribe is preparing to set up their summer camp. Bob, one of the members of the tribe, is a little odd. He's not really much into living together. He cares about his people, but he often strikes out and does his own thing.

This year, Bob, who has a lot of Individual circuitry defined in his chart, decides to set up his summer home on the bluffs of a small creek away from his tribe. He enjoys his alone time, and while building his shelter for the summer, he discovers a new way to bind a large stone to a stick, and he makes a hammer that is a great help in getting his new home constructed.

Roger, Bob's brother, comes down to the creek to visit with Bob. Roger has a lot of Tribal circuitry in his chart. He just wants to make sure his brother is okay. While he visits Bob, Roger sees the cool new hammer. He is astonished at how useful it is and quickly sees the potential for this new tool to make

constructing the new summer camp much easier. He knows that the faster camp is built, the more time there is to gather food and other resources for the winter. Roger asks Bob if he can build a hammer for him to take home. Bob obliges and Roger brings the new hammer home with him.

After using the hammer very successfully, Roger has a lot of extra time on his hands, so he doubles his hunting time. He now has a lot of extra pelts and furs to trade with other tribes. As Roger packs up to leave on his trading journey, he decides to throw his new hammer in his saddle-bag. He shows his hammer to several other tribes who ask him to make them hammers in exchange for pots and other valuable commodities.

Roger returns home with many extra resources for his tribe.

After a couple of years, every tribe has their own variation of Bob's hammer. Roger's granddaughter (who has a lot of Collective circuitry), sets up a government agency to regulate the use and safety of hammers.

When a mutation is adaptive and successfully spread from the individual to the tribe and from the tribe to the collective, a critical mass of energy evolves, and the mutation becomes an integral part of the human experience and part of the human story.

On a personal level, your defined circuits and gates will help you understand why you are the way you are, what drives you, and why you may keep repeating certain themes in your life. Your defined circuits also help you understand your life purpose and what you are here to share with the world.

Defined channels will carry consistent themes in your life. Hanging gates (half a channel) will be themes that you live out in your relationships. You will always be attracted to the other half of the channel, and the theme of the channel will be lived out in your relationship.

The Individual Circuit

Mutation and empowerment originate in the Individual circuitry. If you have a lot of Individual circuitry, you are here to be different, and in order to be happy, you must fully express your uniqueness. You feel different from most people and may even act or dress outside the norm.

The uniqueness of individuality brings change. Because this is energetic, Individual energy doesn't have to "do" anything to bring change. It just has to "be," and it affects others.

When someone has a lot of individual definition in their chart, they may struggle with depression. It can feel hard when you think no one is like you and

no one “gets” you. The important thing to remember is that this is all energy. The Individual can be surrounded by adoring fans but may still feel alone and misunderstood, and it is simply an artifact of Individual energy. It truly is not personal!

The Individual Circuit is comprised of three subcircuits: the Integration Circuit, the Centering Circuit, and the Knowing Circuit. We will talk about these subcircuits in more depth in [chapter 7](#).

Individual circuitry brings empowerment to others when it is fully expressing itself. When you have a lot of Individual circuitry, part of your purpose is to fully express your unique traits and qualities without holding back or feeling shame. This gives others around you permission to also freely express themselves.

The Individual cannot live out their destiny if they are trying to be like everyone else. It isn't correct and stops the flow of evolution and empowerment.

Parents of children with a lot of Individual definition must support the children in the full expression of their uniqueness. If Individuals are pushed down and forced to be like others, they can become lost, bitter, frustrated, or angry. And the Collective misses out on the beauty of the change the Individual is here to bring.

Timing is crucial for someone with a lot of Individual circuitry. When something new is offered into the world, the timing has to be correct. Individuality needs to wait until things “feel” right before it is shared. Mutation is spontaneous, but adaption takes place over time. It takes time to know if a change is going to benefit the tribe and the collective.

And Individual must simply be themselves. The tribe and the collective will determine if the changes brought by the Individual will work on a greater scale and will hold up over time.

Individual circuitry is deeply auditory. People with a lot of Individual definition, especially in the Head and the Ajna, will be auditory learners. They may also have their own internal auditory process.

Children with Individual definition may talk to themselves a lot and may hum or make a lot of repetitive noises.

The Individual Circuit is intuitively claircognizant, meaning that when you have a lot of Individuality in your chart, you often just “know” things. You may not know *how* you know, you just know that you do. This spontaneous knowing can drive logical people crazy. Individuality is not logical at all.

Affirmations for the Individual Circuit

- I am here to be different, and I celebrate my uniqueness.
- I let my inner wisdom develop over time and share it with people who ask.
- I am free to express my powerful uniqueness, and I let my light shine everywhere I go.
- I allow myself to be who I am with confidence and grace.

The Tribal Circuit

Tribal circuitry is all about family, values, reproduction, and caring. Your tribe is comprised of your friends, family, and neighbors.

People with a lot of Tribal definition long to be a part of a group or a whole. These are the people who take care of the family or the neighborhood: the Girl Scout leader, the PTA president, the Neighborhood Watch coordinator.

Tribal energies are responsible for the transmission of values; allocation and management of resources, contracts, and agreements; and birthing and raising children to adulthood. Included in these energies are cooking, educating, sexuality, and business.

People with a lot of Tribal circuitry care about others. They feel deeply responsible for the people in their lives and may sometimes feel or be perceived as codependent. A Tribal person will do whatever it takes to take care of his people. The theme of Tribal circuitry is support.

There are two subcircuits in Tribal circuitry: the Defense Circuit and the Ego Circuit. We will talk about these subcircuits in more depth in [chapter 8](#).

Tribal energy is about allocating and managing resources over time. The tribe survives because of its resources. If you store your grain and manage the allocation of the grain over the winter months, then your friends, family, and children will make it through the winter. If you make good business decisions, then you will have access to more resources and multiple sources in case situations change. Strong tribes have back-up plans for survival.

Contracts such as marriage, divorce, treaties, and business deals are all part of Tribal energies. Agreements about rules and values are also Tribal. Religions and religious beliefs are Tribal.

Sex and sexuality are also rooted in Tribal circuitry. A tribe survives over time because new offspring grow into adulthood. Sexual bonds and family ties are part of sustaining Tribal values. Agreements about raising children and educating children, as well as taking care of children, are all a part of Tribal energy.

War and peace are also in Tribal energies. The Defense Circuit will cause

tribes to go to war if resources or values are threatened. Treaties, peace, and harmony are also rooted in the connection between the Emotional Solar Plexus and the Will Center in the Ego subcircuit of Tribal energy.

Affirmations for the Tribal Circuit

- I feel good when I am with my friends and family. I feel good when I take care of myself and others.
- I set good boundaries for myself so that I can take better care of others.
- I manage my money and my time well.
- I honor my agreements.

The Collective Circuit

The Collective Circuit is all about the survival of humanity. It has two themes: projection and reflection. It projects what is coming next based on lessons from the past, and it reflects the potential and possibilities for the future and shares these with inspiration stores and ideas.

The Collective Circuit contains two subcircuits: the Logic Circuit and the Sensing Circuit. We will talk about these subcircuits in more depth in [chapter 9](#).

The Logic Circuit is, by definition, logical. The left hemisphere of the brain is part of the Logic Circuit. Logic in the Human Design system is all about understanding patterns that repeat over time. For example, we know that spring comes each year after winter and that spring is a good time to plant crops. This understanding comes from repeated experiences over time. This information is predictable and consistent and allows us to make decisions that keep us alive. Logic is about patterns that, in the purest sense, allow us to move toward the ever-evolving perfected expression of humanity and the joy of life.

The Sensing Circuit is all about the human experience and is the seat of the right hemisphere of the brain. The Sensing Circuit is expressed through the Emotional Solar Plexus and has little awareness in the moment. The Sensing Circuit is all about achieving clarity over time. It is abstract and holistic energy.

Collective circuitry is all about sharing. But this is not personal sharing like we see in the Tribal Circuit. This is pure, human sharing, the kind of sharing that comes in situations that involve survival of the species. We see this sharing in times of chaos and crisis. The Collective Circuit is what compels us to guide others to safety or to high ground when there is trouble. People with a lot of Collective energy, particularly in the Logic Circuit, will intuitively know how to fix or improve things. This understanding may be interpreted by others as

criticism, but the goal of the Collective is to express the perfected form of the human experience and to create the infrastructure to support the ongoing evolution and abundance of humanity. As difficult as this may be to understand, this criticism is not personal, and to a certain extent it isn't even about caring so much as it is about sharing the most perfect form of expression. The Collective shares because we are one, and your experience is really the same as mine, even though we are differentiated as two different people. We are still having a human experience that has some common threads.

Affirmations for the Collective Circuit

- I like to see the patterns in all things.
- I wait until it feels right to try new things.
- I share my ideas, stories, and advice with the people who ask for them.



As you can see, all of the parts of the chart are beautifully interconnected and vital for the evolution of humanity. The circuitry gives you a peak into what you are here to do; bring change, nurture, and establish larger frameworks for the overall well-being of mankind.

If you're like most people, you discovered that your life purpose involves energies that include all the circuits. Some of you may have found that you are significantly defined in one particular circuit, and the theme of that circuit has had a deep impact on your life.

You may have also realized that in the sum total of the parts of circuitry, each person on the planet plays an important role in the evolution of mankind. We all need people who bring change, nurture, and care for others, and create larger frameworks to support us in organizing ourselves in a meaningful way. Ultimately, the full puzzle of humanity can only come together when we have all three parts expressing themselves fully, with each individual fulfilling the highest potential of their chart.

Chapter 7

The Individual Subcircuits

Individual circuitry contains three subcircuits: Integration, Centering, and Knowing. Each of the individual subcircuits carries the theme of mutation, transformation, and the ability to articulate new ideas when the timing is right. The Individual subcircuits have a specific task that helps you understand what kinds of change you are here to bring and different energies that influence your ability to make change on the planet.

The Integration Circuit

Integration is a very complex and difficult circuit in that it truly embodies the energy of the soul of humanity. It is a deeply esoteric circuit and one of the more difficult ones to understand.

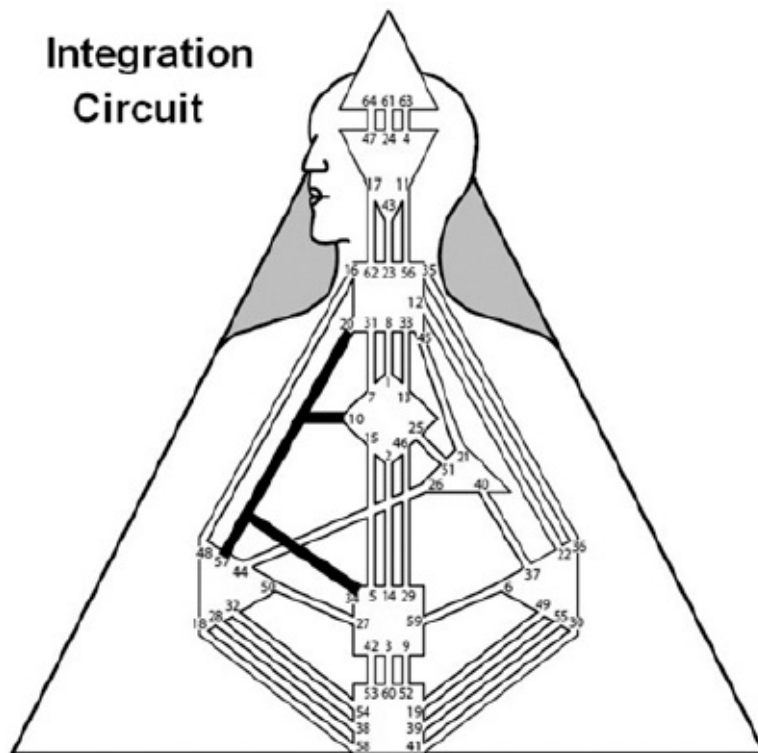

Figure 115: The Integration Circuit develops our awareness of self.

Integration is intuitive, motorized by life force, and driven by identity. When hominids first came into form, they expressed only the Integration Circuit. The theme of Integration is the phrase “I Am.” The job of the Integration Circuit is to develop awareness of the self as differentiated from others and conscious in our form.

When we are not in incarnated form, we exist as formless, undifferentiated unity. It is in human form that we experience the illusion of being separate and define ourselves by our uniqueness. We perceive ourselves to be separate human beings, not a unified whole. This is the power of the human experience. Through perceiving ourselves as separate, we are separate not only from each other, but from God. We seek enlightenment, and it is through the Integration circuitry that we are simultaneously separated and awakened to unity.

On a more practical note, Integration is a profoundly individual circuit. People who have a lot of the Integration Circuit are highly mutative and deeply individual. They may sometimes struggle to feel like they fit in.

People with Integration need time, which may seem counterintuitive, as Integration is rooted in the Spleen (the center for the here and now). Integration needs time for inner reflection and creating new paradigms as new experiences are “integrated” into the archetype of being human. And, of course, in addition to time, Integration also needs to respond. It is a generated circuit.

Integration Circuit Channels

- Channel 34/57: Power
- Channel 57/10: Perfected Form
- Channel 34/20: Charisma
- Channel 20/10: Awakening

Often people with Integration struggle to respond or even be in the moment. They need to integrate before they know what to do. This can sometimes be frustrating if you are trying to act or respond in the moment. Time to integrate or go into the proverbial cave is crucial for these people, especially on an interpersonal level.

It is not uncommon for people with significant channels of Integration defined to be perceived as self-referenced. They are not selfish, just individual by design. It's not personal. It's just the way the energy of this circuit works.

The wiring in this circuit is very complex, with gates overlapping in different channels. This does not happen in any other circuit.

Channel 34/57: Power

This is the original channel of the human archetype. When hominids first came into form, it was this energy that defined the original separation of humanity. This is intuitively based life force. This channel is also deeply auditory and intuitive. People with this channel are frequently employed in some sort of audio production. Sound distortions can be very challenging for people with this channel, and they can be especially challenged if they ever lose their hearing. People with this channel tend to be very clairaudient and can hear voices or intuitive guidance. They will also hear changes in your voice and will intuit things about you from your words and your tone.

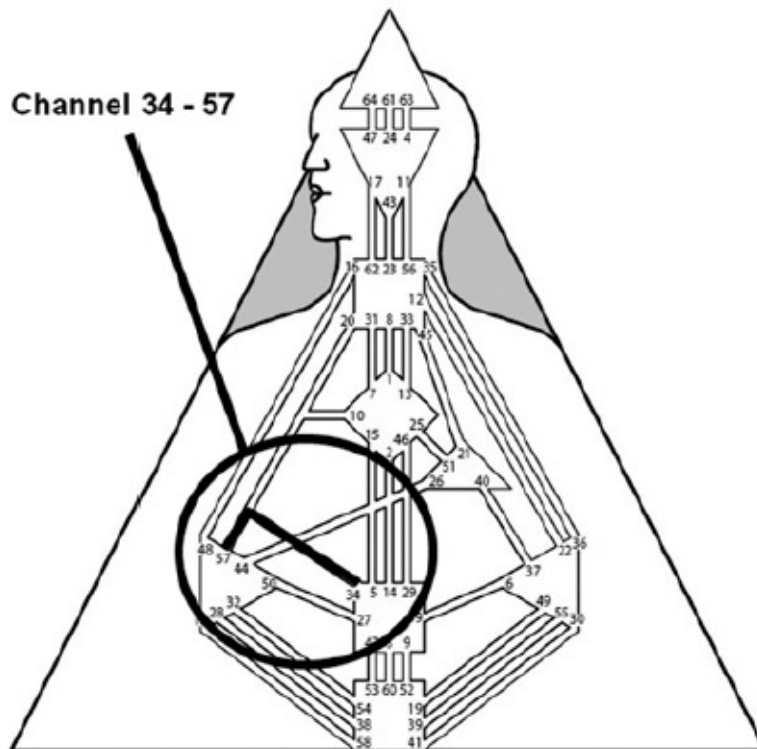

Figure 116: Channel 34/57—Power

Gate 34: Power

Gate 57: Intuition

Channel 57/10: Perfected Form

In the evolution of the human, this was the second channel that evolved: the perfected form of intuition. This channel contains the intuitive, perfected awareness of how to survive in the now.

People with this channel are great people to follow. They always know how to survive. They intuitively know the safest route out of disaster or the best way around an obstacle.

Channel 57/10 people are perfectionists. It is common for this channel to stop taking action if they think they will make a mistake. But it is deeper than just a fear of making a mistake. This is a deep desire to get it perfect, and intuitively they know how to do this.

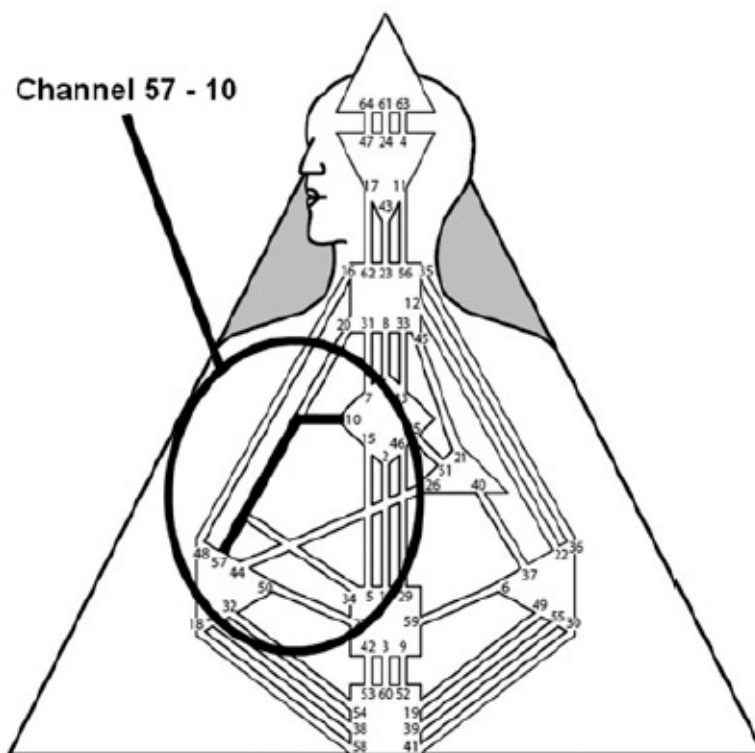

Figure 117: Channel 57/10—Perfected Form

But, notice that this channel is non-motorized and does not make it to the

Throat. It is totally projected. When channel 57/10 tries to offer up its expression of perfection, no one listens. It is only through invitation that the perfection is recognized.

As this is a deeply individual channel, when recognition doesn't happen, coupled with a fear of not getting it “perfect,” people with this energy can truly take it personally. The truth is, they are mutative, offering new and unique perfected expressions that will not be adaptive unless they are invited to share them.

Spiritually, the energy of this gate is very special. The Spleen Center is all about the energy for survival. This is an energy that we share with other animals. In channel 57/10, our intuition is connected to the soul in the Identity Center. We are the only living creatures who are designed to intuit our soul's direction and have the capacity to know if we are fulfilling the destiny of our soul.

Gate 57: Intuition

Gate 10: Love of Self

People with this channel can be very conscious of being on their life path and often have a role in life of empowering others to discover and fulfill their soul's destiny.

Channel 34/20: Charisma

This is the most powerful channel in the Human Design system, which brings sustainable, generated energy to the Throat. This channel is the archetype of the Manifesting Generator, as it is the only channel that directly connects the Sacral Center to the Throat. Power and charisma are contained within this channel, but because it is connected to the Sacral, true power in this channel is expressed in response. That means that even though these people are very, very powerful in a sustainable way, they cannot truly live out their powerful destiny unless they respond. If they are initiating with power and charisma, they will get into big trouble and no one will follow them. If someone with this channel is not living his or her power and charisma, they can become very, very frustrated. Inside, they know how powerful they are, but they can't move that energy unless they respond.

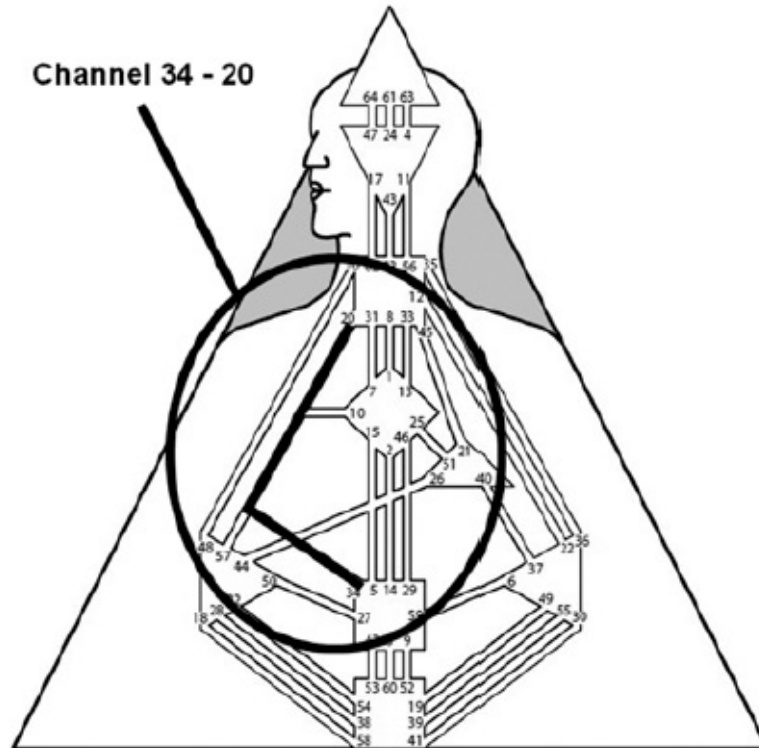

Figure 118: Channel 34/20—Charisma

The big energetic task of channel 34/20 is to manifest thoughts into deeds, but only in response. Of course, with Gate 34 to the Throat through Gate 20, once these people are activated they can be very busy bringing things into form. But strategy is key here. The 34/20 who is not waiting or is without access to the intuition in other parts of their chart can be very busy following idea after idea and burning out their Throat and thyroid but achieving nothing. This is potentially the Don Quixote channel: busy, busy, busy tilting at wind-mills unless directed by influences from the rest of their chart (the 57 or the 43/23 channel, usually).

Gate 34: Power

Gate 20: Metamorphosis

In the evolution of the hominid, channel 34/20 evolved after intuitive survival. It is life force generated to the Throat. It is deeds (the doing of the Sacral) to the Throat. The “doing energy” here is not only based on survival but in sustainable life force energy. This is the energy of working to make sure we

have what we need to survive over time.

Channel 20/10: Awakening

Channel 20/10, the channel of awakening, is the last channel to evolve in the evolution of the hominid into human. With this channel comes the perfection of the self in the now. This is the ultimate expression through Gate 20 of individuation. This is a totally projected channel of awareness. People with this energy have a deep capacity for spiritual awareness, empowerment, and self-love. Channel 20/10 often serves as a teacher of self-empowerment and enlightenment, but its lessons can only be shared when someone asks for them. If a person with this energy tries to force their knowledge out into the world, they are often ignored or even perceived as being critical.

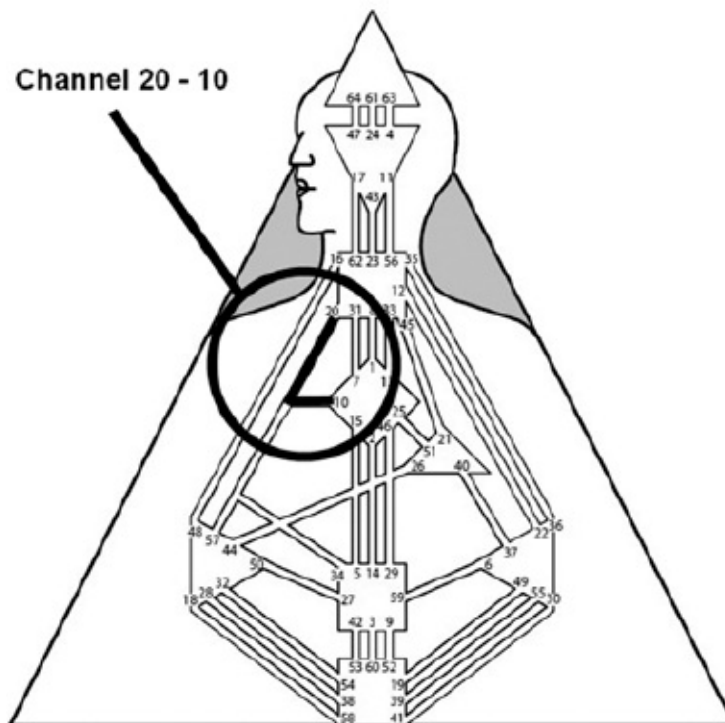

Figure 119: Channel 20/10—Awakening

Gate 20: Metamorphosis

Gate 10: Love of Self

In relationships, this channel can be expressed in a challenging way. People

with the 20/10 configuration, sometimes called the “verbal gunslinger,” can be known for their sharp tongue and vicious words. The language for empowerment or disempowerment is in this channel. If you have this energy or you love someone who does, be extra mindful of the power of your words.

The verbal gunslinger can be a configuration defined within an individual chart or brought together by electromagnetics in a relationship. Either way, it is an energy that requires awareness. It is not personal; it is simply energy. A relationship strategy of getting out of each other's space when the energy is too sharp will help when tongues lose control, as they can and will!

Anytime you have a defined energy from the Identity Center to the Throat, you have the potential for vulnerability, because the voice comes directly from the seat of the soul. When the 20/10 channel is speaking and not waiting for recognition, it runs the risk of either not being heard or being criticized. If this has been your experience, you might find that you have shut down your personal and creative expression. Learn to wait, and the right people will always ask you for your insights.

Of course, this channel can also be the highest expression of integration. Awareness and wisdom rooted in the self, when lived out purely as itself, is ultimately the most empowering energy in the chart. Simply by living strategy and being themselves, the 20/10 channel can empower others to do the same.

The Centering Circuit

The Centering Circuit is considered a minor circuit. It has only two channels, but they are very compelling. Two of its three centers are motors, the Sacral Center and the Will Center.

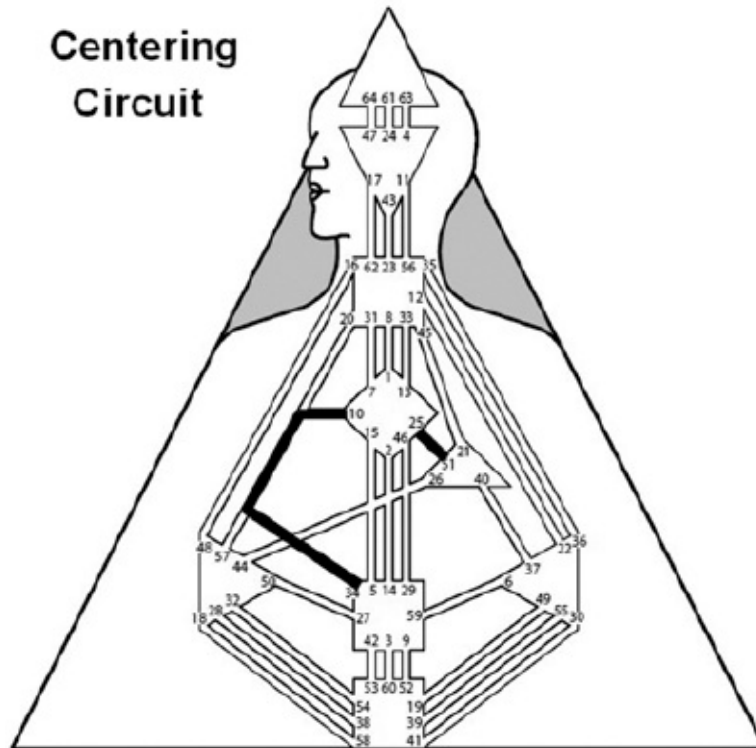

Figure 120: The Centering Circuit focuses change and improvement on the self.

The Centering Circuit acts as a vortex. People who are drawn into the energy vortex of the Centering Circuit are influenced to act more individually, regardless of their own definition. The Centering Circuit is a mutative force, ultimately designed to initiate others in the love of self and Spirit, and it will use life force energy (Sacral energy) to make it happen.

Its aura-busting qualities are only matched by the power of the Defense Circuit. When these two come together it is quite a challenge, with both circuits pushing each other out of their natural energy patterns. The Tribal becomes more Individual in expression, and vice versa.

The Centering Circuit has no potential for awareness, so it is purely mechanical, the experience of the self with no expression. There is nothing here for the Centering Circuit to report other than its experiences; no awareness, no expression, no channel to the Throat. It is a purely generated circuit only capable of sharing its process in response.

Contained within the Centering Circuit are mystical conversion through experience and initiation. These experiences can be shocking to the self and to

others. The Human Design system was born of such energy, an initiation through a shock. It is also Individual in that the shock of the Centering Circuit can be empowering or alienating, depending on your perspective.

With the Will Center as part of the circuitry, the Sacral needs rest to sustain its energy. The irony of the Will and Sacral together is that you have sustainable work force energy that needs a break. Again, strategy protects the Individual, and a Sacral with a Will responds to rest.

The Centering Circuit is empowering in another way, too. Because there is perfected behavior of the love of self and Spirit here, and it is initiated and sustained, the Centering Circuit can energetically move people into self-love simply by being. Again, there is no convincing and talking here. The Centering Circuit, merely through responding, will empower others to love themselves and consequently create mutation.

Think about this. Tribal energy is all about sacrifice for the greater good of the whole. When the individual Centering Circuit steps into the Tribal aura, caring mutates into caring about the self.

Centering Circuit Channels

- Channel 34/10: Exploration
- Channel 25/51: Initiation

Channel 34/10: Exploration

The combining of Gate 34, power, and Gate 10, the love of self, creates a channel that represents following one's convictions. When this channel comes together, it is purely generated, and it is through response that the perfected form of power can happen. Through responding, people with this energy are able to behave with their power correctly, or are behaving in a way that is powerfully correct. This is a deeply individual channel, and when you are in its presence, you will be drawn into behaving correctly as long as you are responding.

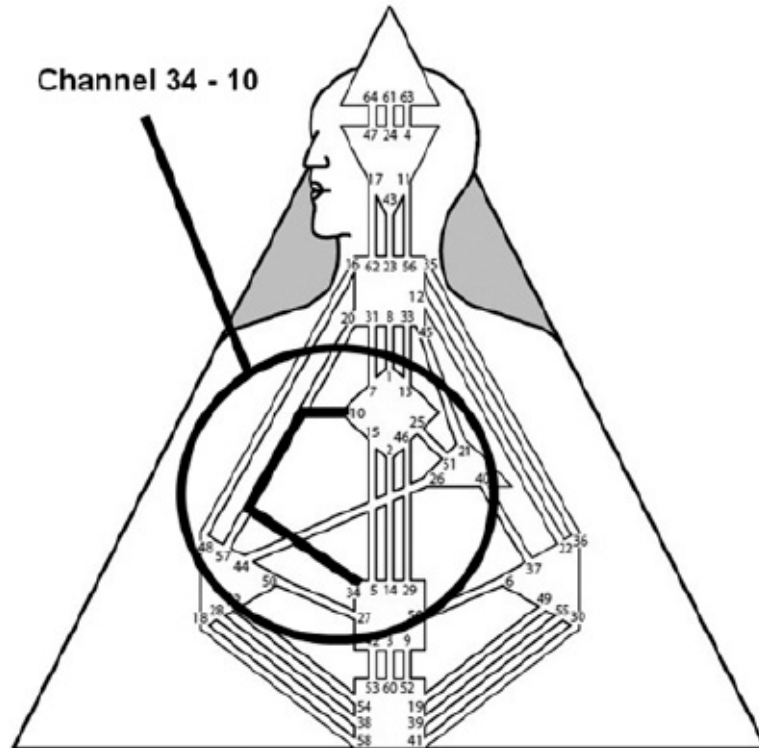

Figure 121: Channel 34/10—Exploration

Gate 34: Power

Gate 10: Love of Self

The beauty of this channel is that it is purely generated. People with the 34/10 merely need to act correctly in response in order to demonstrate power. There is no convincing or sharing here. There is no Throat Center here. This is pure empowerment by being and responding, and as with all Individual circuitry, these people can empower others simply by being the purest expression of the self.

You can see how this is a small step up from Integration. Here we go from individuation to individuality, acting correctly and empowering through right action by being.

Channel 25/51: Initiation

Channel 25/51 is mystical. Notice that this is a totally projected channel. You don't have to do anything to be initiated. Life initiates you.

Initiation in this channel is Will based. The willpower of the 25/51 is less about willpower in the traditional sense and more about having the will to survive the initiation. Initiation can be shocking, dramatically life altering, and, of course, unexpected. But the initiation here is always about bringing the individual closer to Spirit.

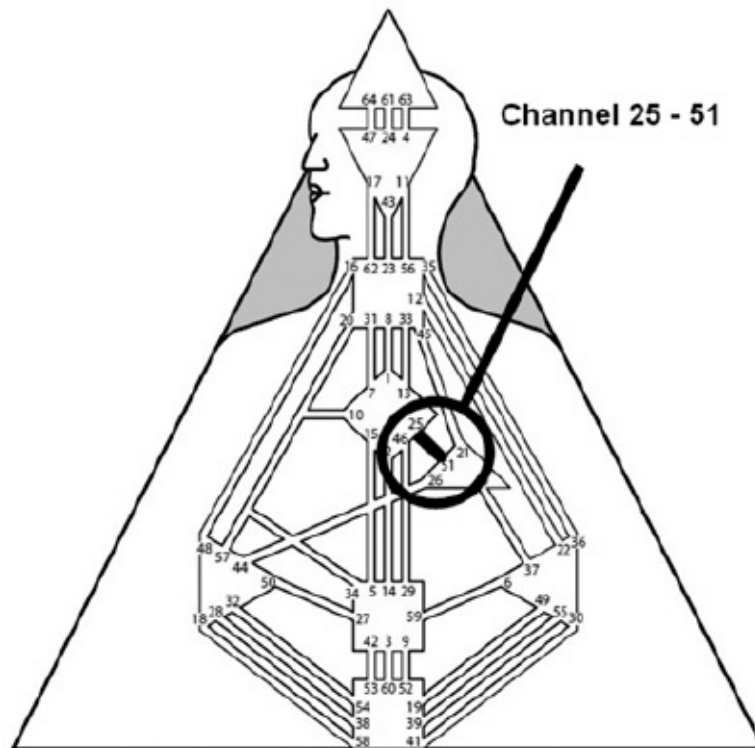

Figure 122: Channel 25/51—Initiation

Sometimes we call this the channel of the shaman or priestess. The shaman and the priestess have to “die” to the ego before they can emerge into their wisdom. This energy is archetypically located here.

Gate 25: Love of Spirit

Gate 51: Shock

On a more practical note, the channel can be very competitive—or not. Remember, in Human Design, energies are thematic. That means that people who have this energy defined stir up competition in others but are not necessarily competitive. In fact, sometimes they are not competitive at all, but

others definitely compete with them.

Simply by being present in the energy field, the geometry, and the matrix, the 25/51 will radiate initiation and it is amplified by others. They do not have to seek it. They will never find it. It is projected. It comes to them and then shocks them into Spirit (or bitterness . . . this is projected, after all).

The Knowing Circuit

The Knowing Circuit is the last of the Individual Circuits. It is the only Individual Circuit that is designed for transmission and implementation rather than experiencing, as we saw with the Integration and Centering Circuits. The Knowing Circuit mutates the tribe and the collective when the timing is right.

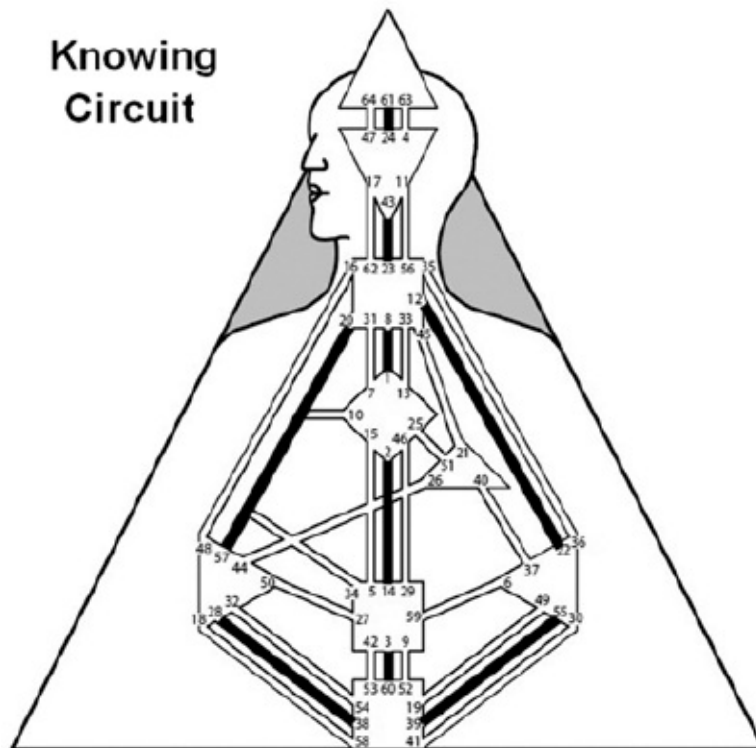

Figure 123: The Knowing Circuit mutates the tribe and the collective when the timing is right.

Timing is everything in the Knowing Circuit. In this circuit we see both centers for time: the Spleen, which is about the now and right action when the

timing is right, and the Emotional Solar Plexus, which is about the energy for expression after taking time for clarity.

The Knowing Circuit also contains struggle. Mutation has to struggle to take hold in the tribe or the collective. Think about this. Without the struggle to create meaning, we would be riddled with useless and possibly dangerous mutations that don't serve people. (In biology, imagine a world filled with frogs with fifteen feet and twelve eyes, most of them useless and possibly even endangering the well-being of the frog over time.) A worthwhile mutation has to struggle against the status quo to prove its effectiveness.

Of course, with timing and struggle being a part of this circuit, it's easy to imagine the challenges facing people with significant definition in this circuit. You have to trust and wait for the right time to share what you know. If you do, you'll be considered a genius. If you don't, you run the risk of being misunderstood.

This is not logical or holistic energy. The Knowing Circuit simply knows. And it doesn't know how it knows. It just knows that it does. If someone has a lot of Knowing Circuit definition mixed with Logic circuitry, which can be a doubtful kind of energy, he will have a tremendous amount of self-doubt until he understands how he is hardwired.

Not only can doubt be challenging for the Knowing Circuit, but, as with all Individual circuitry, there is a struggle to be heard and understood. If you're here to share something that you "know" and it's not logical, people have never heard of it before, and there is no paradigm to plug it into, you can see how the struggle to be and feel understood can be quite profound for this circuit. The result of this experience can be melancholy. Mood and melancholy are keynotes for this circuit.

Fortunately, there is built into this circuit a certain lack of caring. It doesn't mean that individuals don't love. If an individual has a lot of Tribal energy, they will be driven to connect and try to share. But an Individual by design is not necessarily nurturing, and she can sometimes be lost in her own mutation, oblivious to the perceptions of others to a certain degree. Of course, all of this depends heavily on what else is defined in the chart.

Being heard and waiting for the right timing for the right words (or not), is one challenge for this circuit. The other challenge is listening. So much of the Knowing Circuit is going on inside the person. These are people who can certainly get lost inside their thoughts, insights, and feelings. It can feel frustrating to others to try to connect with this energy. Remember, the "ignoring" is not really ignoring, but rather just the symptom of someone who

likes to think and feel—a lot. If you love someone with a lot of Knowing Circuit definition, touch them to get their attention. Their “not listening” is not personal.

Knowing Circuit Channels

- Channel 61/24: Awareness
- Channel 43/23: Structuring
- Channel 28/38: Struggle
- Channel 57/20: The Brainwave
- Channel 3/60: Mutation
- Channel 14/2: The Beat
- Channel 1/8: Inspiration
- Channel 55/39: Emoting
- Channel 12/22: Openness

The most powerful message you can share with someone with a lot of definition in the Knowing Circuit is the importance of celebrating their uniqueness. These are people who are truly here to be different. And in the mechanics of evolution, not all mutations are adaptive. There will be some Individuals who are just plain different, and it's all perfect. It only becomes a problem when they try to be someone they are not.

Channel 61/24: Awareness

The 61/24 is the initiating channel in the Knowing Circuit. The initiation energy for this circuit starts in the Head with inspiration. Gate 61 is considered one of the gates of madness (along with Gates 63 and 64). The “madness” of 61 comes from the perpetual question of “Why?” which leads to an inspiration through “knowingness,” a sudden awareness of information that doesn't have any proof or logic.

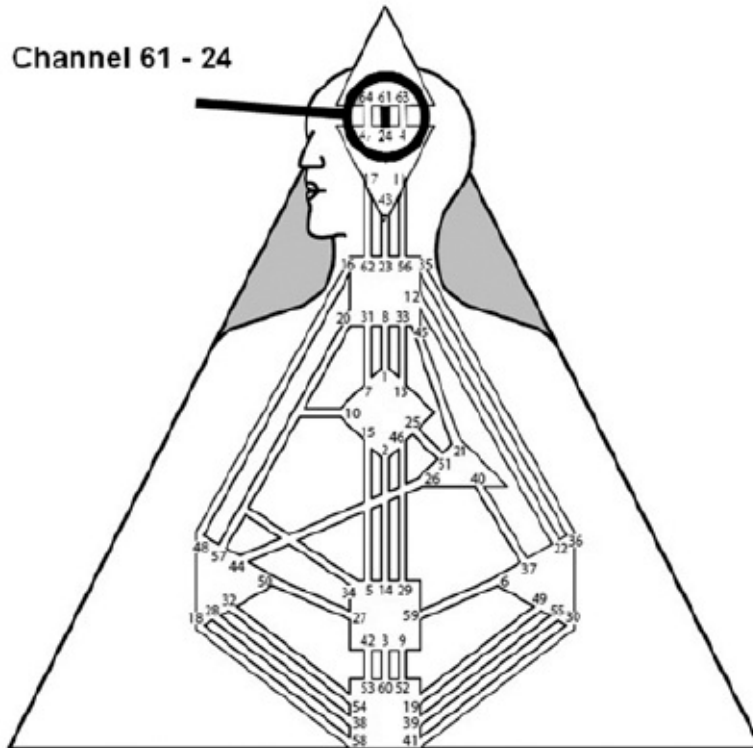

Figure 124: Channel 61/24—Awareness

Gate 24 tempers knowing, focusing on the possible, sometimes filling in the gaps in the knowing leaps of Gate 61. Gate 24 inherently understands timing and waits with much greater awareness than Gate 61.

Thinking is sort of like a sport to this channel. Thoughts flow like waves, much like emotions work in waves in the Emotional Solar Plexus. The 61/24 stretches out their awareness to try to know the unknowable. This can be a very mysterious and occult awareness.

Gate 61: Mystery

Gate 24: Rationalization

This is mutative thinking. It is unique and new. And because all mutation has to eventually stand the test of time and repetition, it is a knowingness that has to wait for correct timing. In this case, because this is an energy that has to be recognized or invited out of you, the knowingness of the 61/24 has to wait for an invitation in order for the timing to be correct.

As with all Individual circuitry, this is a deeply auditory channel. People with

the 61/24 often have a deep internal auditory process. It is normal for the 61/24 to have a lot of noise or voices in their head. Although it is hard for this channel to be perceived as different (as demonstrated by the melancholy in their charts), people with the 61/24 channel should celebrate the uniqueness that is Individuality and should not take the timing as personal.

Channel 43/23: Structuring

Gate 43 is the beginning flow of the energy that has the job of translating the internal auditory process of the Knowing Circuit into words. The 43/23 is the first expressive channel of the Knowing Circuit. This is the channel that contains the energetic potential for the Individual auditory process to be translated into language. All those sounds, all that wordless thinking is pushed through this channel and given language. Or not. People with this energy often say, “I know, I know, I know . . .” a lot.

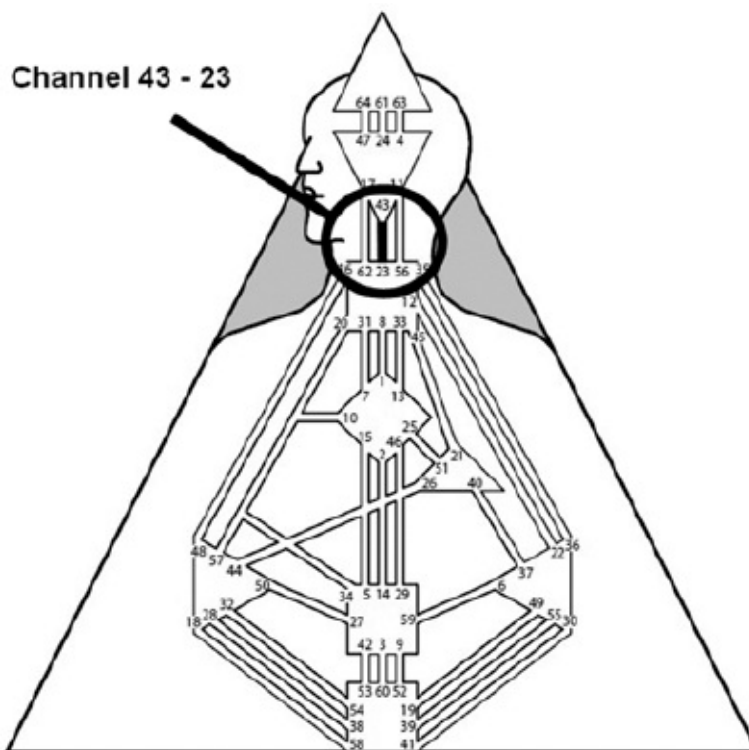

Figure 125: Channel 43/23—Structuring

Gate 43: Insight

Gate 23: Assimilation

The struggle of the Individual knowing process is translating insight into language. Knowingness is instant, a sudden epiphany of awareness. When the Individual blurts out this knowingness without recognition or invitation, there can be a tremendous struggle to articulate or to be understood.

People with this energy serve themselves and the mutation they carry best by waiting for the right timing and allowing other people to ask them for what they know. If they are not waiting, there is a possibility that the timing for the expression of their knowingness will be wrong and they can potentially feel misunderstood.

The most important thing a person with this energy can do is to wait for others to recognize that the 43/23 knows and to ask them for their insight. This can feel like a frustrating process while you're waiting, but it is well worth the wait. It saves a lot of personal pain and rejection in the long run.

We are heavily biased toward logic. Logic demands a systematic approach and proof of knowingness. This can be especially difficult for people with the 43/23. They don't know how they know. They just know. For children with this, school can sometimes be difficult as they struggle to explain how it is that they know what they know. They have to learn to value their knowledge enough to wait for the right people to ask what they know.

Like all Individual channels, the 43/23 is deeply auditory and learns best by listening, but the listening is often self-directed. They want to hear what they want to hear. And, once they hear it, they get lost in thought.

Sometimes we call the 43/23 the channel of not listening. It's not that they aren't hearing you, it's simply that they can get very lost in their own thoughts and tune out the outer world. A gentle, loving touch is usually all that's necessary to get their attention.

Of course, these people are here to bring change. The most respectful thing you can do for a 43/23 is to ask them what they know. And give them time and space to think. They love to think. They need to think.

Remember, the Head and the Ajna are not decision-making places. There are no motors there. Just awareness and thoughts. Life is acted on based on other awarenesses.

Channel 28/38: Struggle

The channel of struggle is one of those energies that really needs a lot of awareness. It's also crucial that if someone has this energy, they understand that

struggle is something everyone faces at some point in his or her life. It's not about screwing up, getting it wrong, or always taking the hard way.

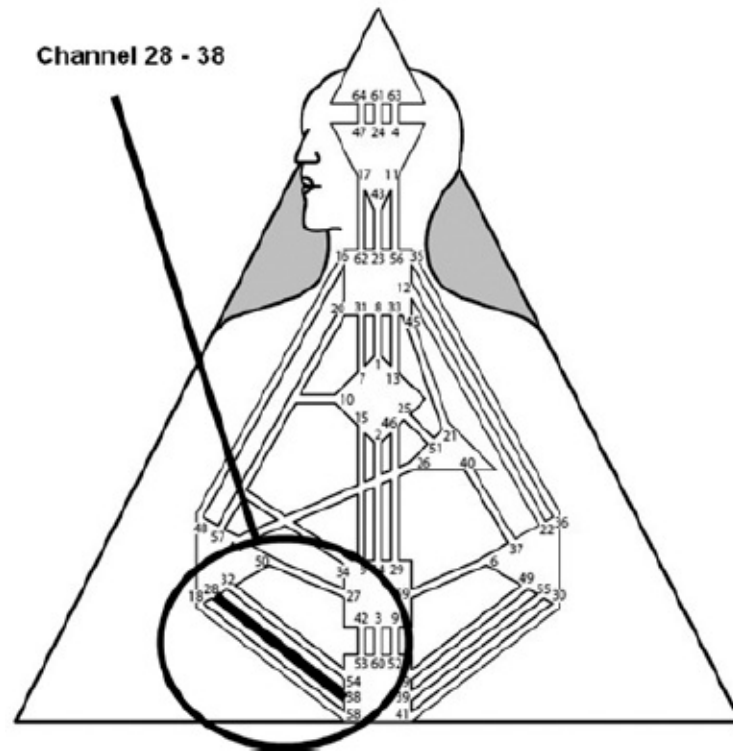

Figure 126: Channel 28/38—Struggle

The energy of struggle in this channel is first and foremost related directly back to the possibility of evolution. People with this channel are ultimately designed to evolve. But any kind of change or mutation has to meet with resistance to test it out and make sure that it is indeed a good change on a personal (and eventually a collective) level.

The first struggle in the 28/38 channel is all about testing to see what is adaptive and what isn't. It's important to remember that when you have this channel that your personal struggles are for the greater good.

The second struggle in this channel is the struggle for the meaning of life. You wonder whether the struggle is worth the effort and endurance necessary to bring it forth and endure. This can sometimes lead to youthful experimentation with the meaning of life until the value of life is discovered.

Gate 38: The Fighter

People with this energy usually take their lessons of survival and the value of life and share them with others. Many coaches, therapists, and motivational speakers share the story of their own personal struggles as part of helping people transform and embrace the true value of life.

When people have this energy and don't understand it, it can sometimes create some bitterness. People with this energy need to wait for recognition or invitation to engage in the correct struggle, otherwise it can feel as if they are fighting and struggling constantly.

Correct struggles may feel difficult, but they are ultimately worth struggling for. When invited to share their insight, the 28/38 can actually make the Individual circuitry transpersonal. The invitation helps them share the true value of life and ultimately forces Individuality to care. In its highest expression, this energy loves challenge. Easy is boring and meaningless.

Channel 57/20: The Brainwave

Gate 57 and Gate 20 are both part of several circuits, so the wiring in this channel is quite complex. In the Knowing Circuit these energies function differently than in other circuits.

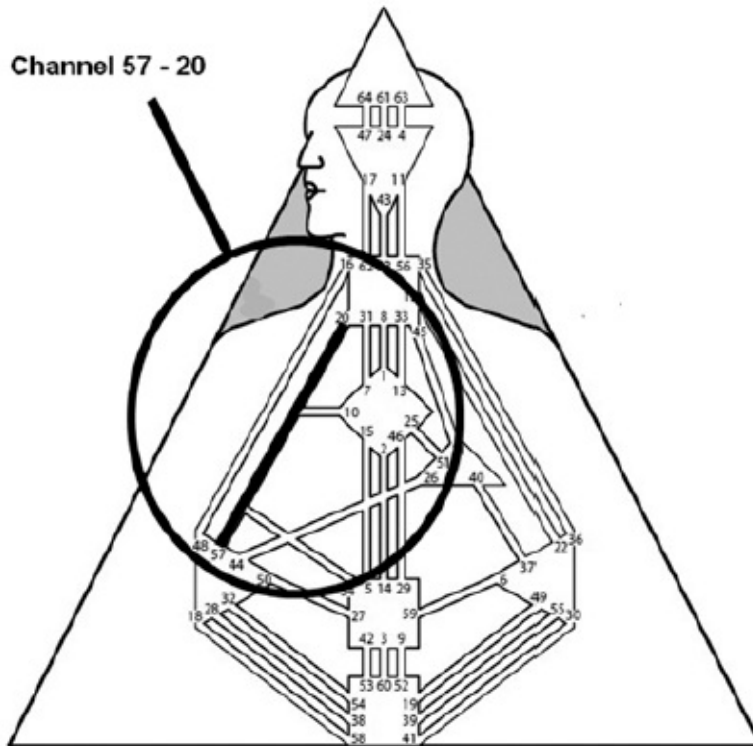

Figure 127: Channel 57/20—The Brainwave

This channel is pure intuition to the Throat Center. Its awareness is penetrating, splenic, and in the now. When people with this energy speak, they speak from their intuition and a sense of what is to come in the future.

Normally, Individual energy does not care. It is an energy that is involved with the self and the experience of the self. But in the Knowing Circuit we see a different possibility for this energy. In the stream of energy from the Root to the Spleen to the Throat, the 57/20 is forced to intuitively unify the right people with the right skills to create an expression of what is truly valuable in manifested form.

Gate 57: Intuition

Gate 20: Metamorphosis

In other words, the discovery of the value of life in the Channel of Struggle forces the 57/20 out of its Individuality into an energy of caring, and the 57/20 has the capacity to bring people together in the name of expressing that value.

People with this energy do well when they wait for people to ask them for

their insights and contributions.

Channel 3/60: Mutation

The 3/60 is a very important channel on a genetic level, and it has a powerful ability to bring change to the world. This is one of two channels that makes the Sacral response mutative by nature, and when the energy of the 3/60 is on, it responds to change or mutation.

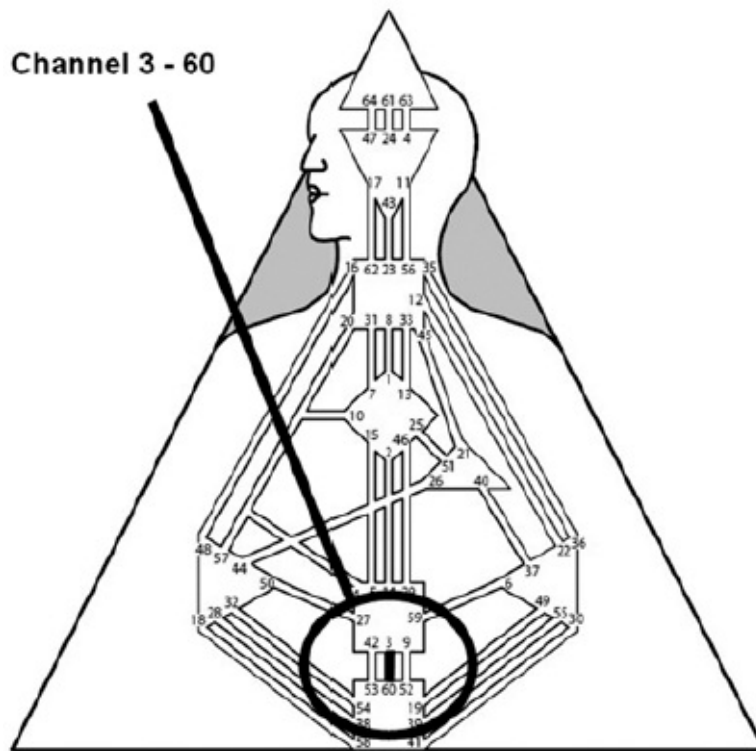

Figure 128: Channel 3/60—Mutation

Gate 60 limits the expansive nature of its electromagnetic, Gate 3, and only responds if the mutation seems to look good and adaptive.

The 3/60 is one of the three format energies. The format energies operate in pulses and adrenalize the energy of the Sacral. When these energies are pulsing on, they are powerful and vibrant, ready to get things done. When these energies are off, it's hard to get things done, almost as if the adrenaline energy of the Root and the life force energy of the Sacral are unavailable. Unfortunately for people with this energy, they usually have to keep working, even when the energy is off.

Gate 3: Ordering

Gate 60: Acceptance

The 3/60 responds to work and reproductive opportunities that are mutative. On a purely genetic level, the 3/60 is all about genetic mutation, and when both of these energies come together to reproduce, the offspring will bring in new energy and genetic material.

In terms of work, the 3/60 pulse responds to work that is transformational and mutative. People with this energy often have or want to have unusual jobs that can bring change to the world.

Like all mutative channels, there is an energy of expansion and then resistance contained within this channel. Gate 3 reaches out to bring in change, and Gate 60 integrates the change with the old genetic material, stabilizing the mutation.

Channel 14/2: The Beat

This channel is in some ways the luckiest of all the energies in the chart. The 14/2 is all about generating and managing resources—usually money, but any resource that is associated with wealth.

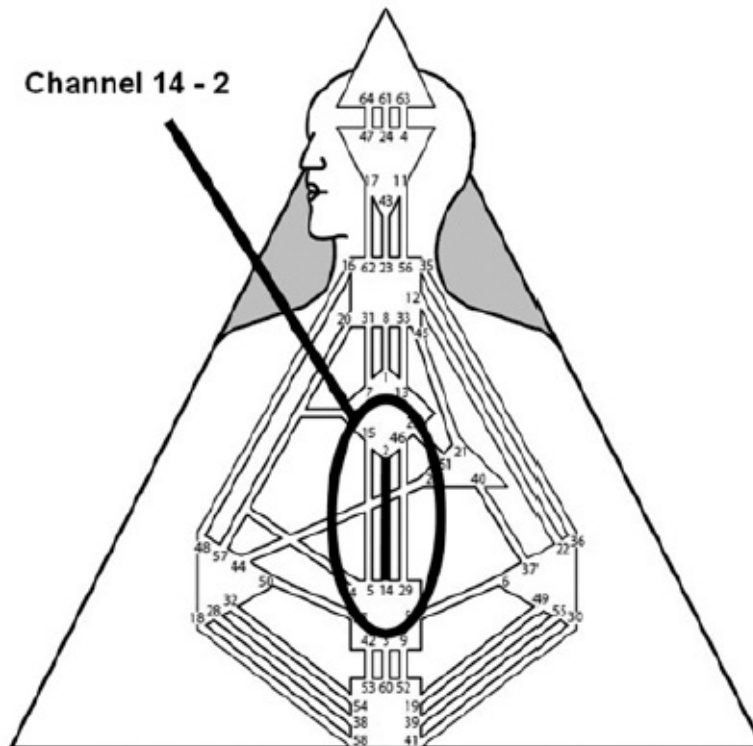

Figure 132: Channel 14/2—The Beat

The 14/2 works to energize the direction of the soul (Sacral to Identity connection). This channel responds to mutative work or life opportunities that bring resources that make the journey of the soul easier. It's much easier to follow your life path if you have the resources and don't have to worry about the money.

There is energy in this channel for working to make money, as well as energy for managing or allocating money. When both work together, there is tremendous opportunity for resource generation. On its own, Gate 14 works very hard to make and save money, while Gate 2 spends it.

Gate 14: Power Skills

Gate 2: Keeper of the Keys

This channel is the energy of the individual who can truly impact the world. If you're going to be strange, have money, because money will give you power to influence and insulate you from some of the pain of being “different.”

Remember that this is a purely generated channel. The energy in this channel

This is a projected energy. The mutation of this contribution isn't influential unless it is recognized or invited. If it is connected to a motor, it will have a better chance of being heard, but it will still be vulnerable.

People with this energy are inspiring and are here to be creative role models. While the contribution may not be entirely mutative, its full expression as a creative role model inspires others and can be the catalyst for mutation in the world.

The 1/8 has to develop its communication skills to be recognized correctly. With Individuality, we know this can be hard. The challenge of being an agent of change is articulating paradigms that are new. The theme here is express yourself (or not), but only when you're recognized.

If the 1/8 isn't waiting for the right recognition, it runs the risk of sharing from that deep place of the soul and not being valued or heard.

Channel 55/39: Emoting

The 55/39 is a deeply emotional energy that can experience high highs and low lows. It is a power and creative energy when the mood is correct. There is energy here for music, poetry, and other creative endeavors.

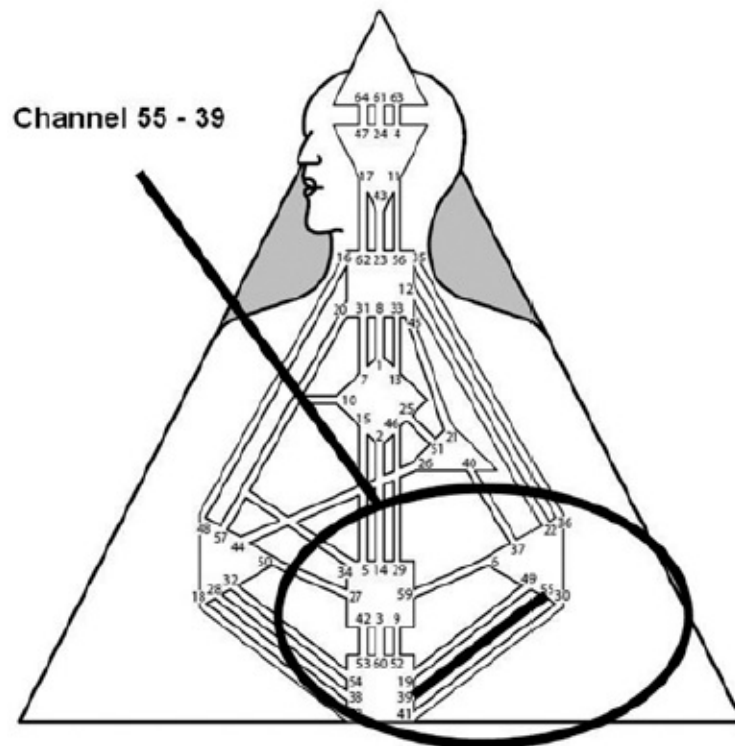

Figure 131: Channel 55/39—Emoting

Creative energy has two distinct kinds of cycles. This channel is punctuated by an inner creative cycle that sometimes can feel like melancholy. It also experiences an outer creative cycle that can be joyful, bubbly, and outwardly expressive. Both cycles are crucial to the creative process.

The real challenge with this energy is to understand the nature of creative cycles. It is very easy when this energy goes down into an inner cycle to mistakenly think that you are depressed or that something is “wrong” with you. The minute you get into your mind about where you are with your creative cycle is when you can actually make yourself depressed by overthinking the melancholy.

Gate 55: Spirit

Gate 39: Provocation

Because this energy is also emotional, the right mood and the right timing for expressing are very important. The mutation of this creative energy can be shared and adopted when the timing and the mood are correct. If not, there can be an enormous amount of tension that builds up here, and the expression of this energy is either ignored, provocative (in a bad way), or self-destructive.

This channel is far away from the Throat Center and is therefore dependent on others to dictate right timing. People with this energy must wait for recognition before they can share their creativity. This can further trigger a sense of frustration or melancholy. People with this energy often feel that no one wants the creativity they have to offer.

On the spiritual side, this channel is also about lack and abundance. Remember that in mutative circuitry there is an inherent energetic push and pull in each channel, a system of energy checks and balances, to make sure that a mutation is good. Gate 55 contains a deeply mystical possibility of abundance, while Gate 39 responds with the potential energy for lack, good deals, and hoarding.

Because abundance and food are often intertwined and this channel is deeply emotional, there can sometimes be a challenge with 55/39 energy and emotional eating. Awareness of this tendency can help break patterns of moody munching.

The purpose of the entire channel is to restore people to the flow of abundance. This channel is not only deeply emotional and creative, it can also

be rather provocative. The provocation in this channel is all about breaking tension and the status quo and restoring an awareness of Spirit as the source of everything. This can be a profoundly magical and alchemical energy when it is in the right mood.

Channel 12/22: Openness

The 12/22 is the only manifested Individual channel (motor to the Throat). It is deeply emotional and has to wait for the right mood to speak. The theme of this channel is self-expression. People with this energy can talk about their feelings, their creative contributions, and what is unique about them—but only when they are in the mood to.

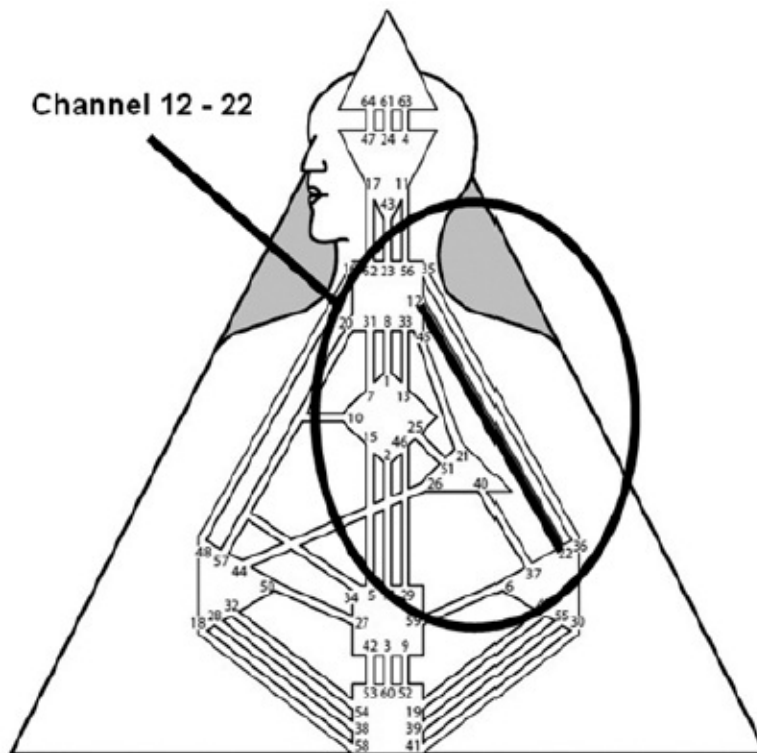

Figure 132: Channel 12/22—Openness

If the mood is right, then this energy is heard and can be quite transformative. But if people with this energy try to communicate when the mood isn't right, they often will come across as angry. There is a lot of potential anger here.

But there is also grace and charm. The 12/22 is designed to wait for the right

mood, and then it can come in and articulate and express with passion, beauty, grace, and more, deeply impacting those around them.

The theme of the Individual process is articulation. The Individual struggles to articulate what is new and unique about it. When there is no paradigm to speak into, it's hard to bring change.

Gate 12: Caution

Gate 22: Openness

As we have seen in the entire Individual process, right timing is crucial for correct mutation. This becomes more difficult with this channel as it is a motor directly to the throat. This is intense energy with high highs and low lows. It's hard sometimes with this energy to remember to inform and then express yourself.

There is also shyness here. It can be a secret kind of shyness, one that others would never suspect hides inside this Individual. The shyness is rooted in the struggle for articulation. It is not unusual to see people with either hearing or speech difficulties with this channel.

Music, passion, poetry, and other intense creativity lives here. People with this energy can also be quite romantic and even seductive. But again, timing is everything.

Spiritually, this energy also connects the voice to Super Consciousness. Sometimes the Individual is simply speaking for Source and serving as a channel. Source constantly seeks to expand, and the Individual has a primary role in being a messenger for this expansion.

Chapter 8

The Tribal Subcircuits

Tribal circuitry is all about love, connection, and nurturing. It contains within it the energy for creating resources, sustainable nurturing, and also war, if necessary. The Tribal Circuit contains two subcircuits: the Defense Circuit and the Ego Circuit. Both of these subcircuits will help you understand how you love and how you work.

The Defense Circuit

The Defense Circuit is the energy that sustains life on this planet. Rooted in this circuitry is the actual act of sex, sexuality, bonding, raising children, fighting, and, of course, defending. Providing resources for the tribe, as well as values, rules, laws, responsibility, and cooking are also attributed to this circuit.

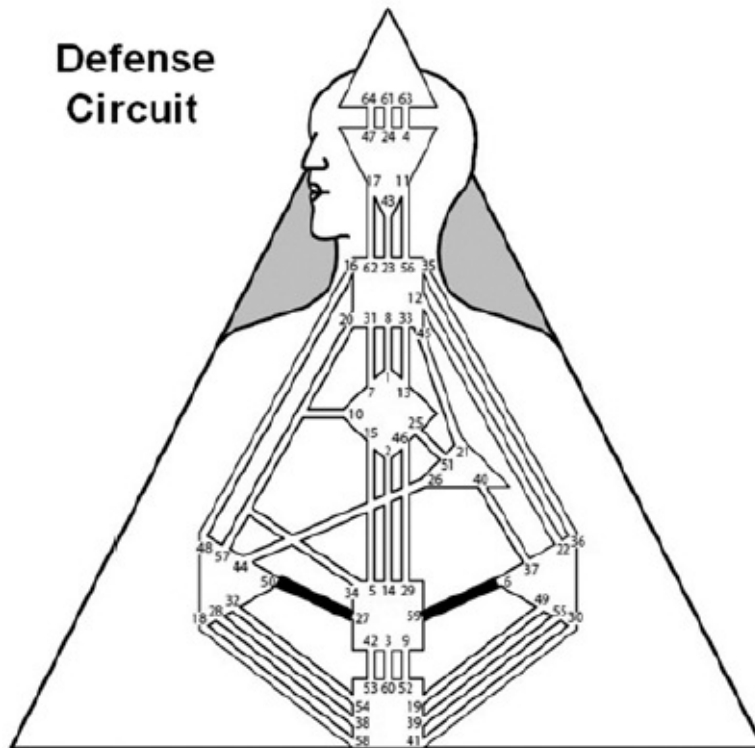

Figure 133: The Defense Circuit

The Defense Circuit is the glue that binds the family and the tribe together. It is one of the seats of love in the chart. The love of the defense circuit is wild and powerful, the kind of love that gives mothers superhuman strength and that makes men go to war.

Here we also find the energy for sex and sexual conquest and all the rules and regulations about sex and reproduction. The energies of the Defense Circuit show us that sex has life and death consequences and needs to be entered into only after deliberation.

The only energy centers in the Defense Circuit are the Sacral Center and the Emotional Solar Plexus. It is a purely generated circuit. It is also sustainable—it has to be. Raising children requires sustainable energy. You can't just quit or the children will die. The love generated here is part of the sustainability. It is in the name of love that we sustainably commit to nurturing and raising children and are deeply invested in the outcome.

Contrasting with the love in the Defense Circuit, we also find the energy for war. Resources and tribes must be protected and defended. The acts of war committed from this energy are actually the greatest acts of love. The warriors give up their life force for the greater good of the tribe. Just as with sex, the energy for war is designed to be deliberate, because the consequences are life-changing.

Everything in the Defense Circuit is for the tribe. There is no individuality here, nor is there a greater desire to help humanity. The Defense Circuit doesn't care what's going on in the world so long as the family is safe, well-fed, educated, and happy.

The energies of the Defense Circuit are very, very powerful. They are capable of breaking into people's auras. Standing in the energy of Defense will force you out of any Individuality you have in your chart and compel you to conform. This is the energy that makes everyone behave at Grandma's family dinner table. Take out your earrings, cover your tattoos, and “be normal.” These are the rules of the tribe. The mantra here is, “When in Rome, do as the Romans do.”

Defense Circuit Channels

- Channel 59/6: Reproduction

- Channel 50/27: Preservation

Channel 59/6: Reproduction

This channel is the archetype of masculine energy. Here we have the energy for the provision of resources, war, and sex.

Gate 59 without Gate 6 is not emotional. It can be in the moment and spontaneous.

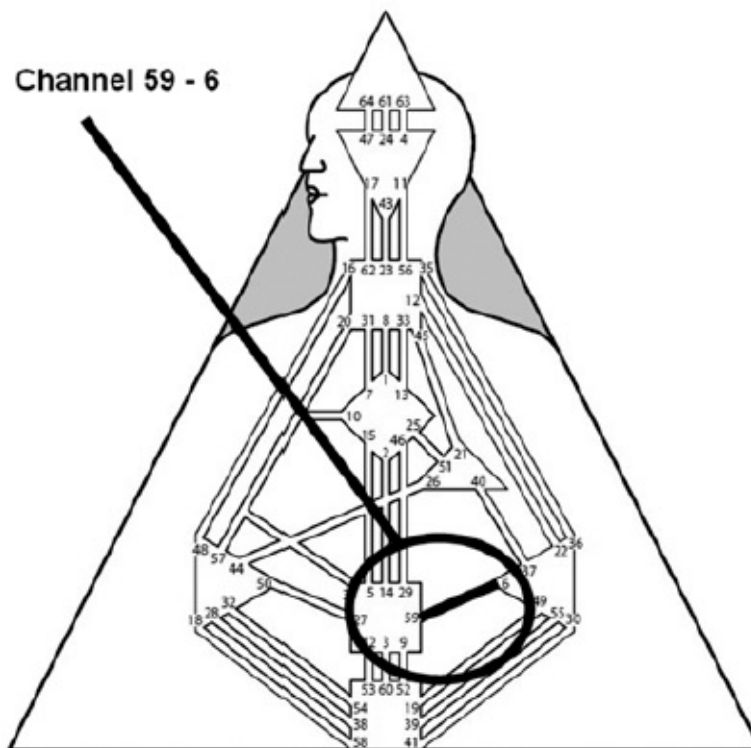

Figure 134: Channel 59/6—Reproduction

Notice that this half of the circuit is also emotional. It needs clarity over time. Wars should be fought after there has been time to really get clarity about the issues. A war fought in the moment without time for clarity can be reckless, deadly, and destructive.

The same applies to sexuality. Sex, by design, is not intended to be a spontaneous act. It's an act that needs clarity over time. The consequences of sex are handled by the values of the tribe. Sex outside the context of the rules of the tribe, or that happens without forethought, can deeply impact the whole

tribe. Think of the teenager who has sex, gets pregnant, and then the grandmother and aunts have to raise the baby.

As you can imagine, the nature of sex and war can be tricky if you don't wait for emotional clarity. Sex and war are seductive, but both can have dire consequences.

Gate 59: Sexuality

Gate 6: Friction

This is also the part of the Tribal Circuit that is all about providing resources. The 59/6 demonstrates love by working and providing food and shelter. This is caring but not nurturing. The love of the 59/6 will be all about resources and working to give. (And, of course, getting rewarded with sex.) None of this is personal. It's all energy.

Channel 50/27: Preservation

While sex, reproduction, and war are all emotional and require time for clarity, the other side of the Defense Circuit, the Channel of Preservation, is intuitive, immediate, and nurturing. The energy of the archetype of the Good Mother is contained within this channel. This is the energy for goodnight kisses, bed-time stories, chocolate chip cookies, and the watchful eye of motherhood helping the child with homework.

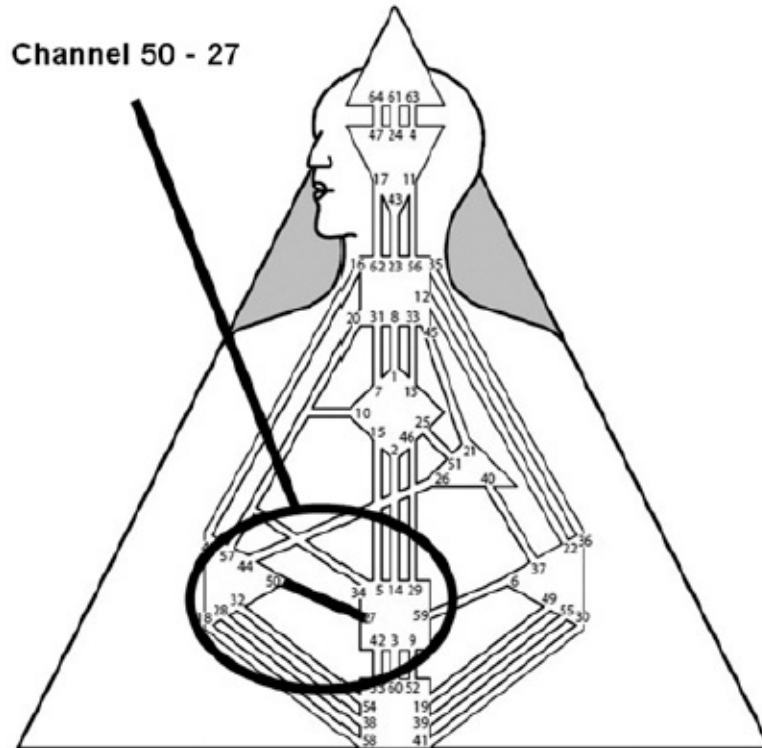

Figure 135: Channel 50/27—Preservation

The 50/27 is also about the transmission of values and education. The drive of the 50/27 is the preservation of the tribe.

A tribe survives to reproduce when it is well fed, educated, and the values of the tribe can be transmitted to the next generation. Time is required for reproduction, but once the child is born, intuitive nurturing for survival is immediately necessary.

This is also the energy of the court system, fairness, and rules. It is not emotional. The letter of the law has dominion over the spirit of the law. Fair rules can only be implemented without emotions. Rules are rules. Gate 50 is the cauldron where the “stew of values” is cooked. Gate 27 is the ladle that dishes out the values. Values on their own are nice, but they have to be transmitted. Transmission of values is also crucial for the maintenance of tribal unity.

Gate 50: Values

Gate 27: Responsibility

The Ego Circuit

The Ego Circuit contains the Emotional Solar Plexus, the Will Center, and the Root. It is creativity and bringing forth agreement into material form when the timing is correct. The Ego Circuit, like the Defense Circuit, has specific aspects that require time for clarity.

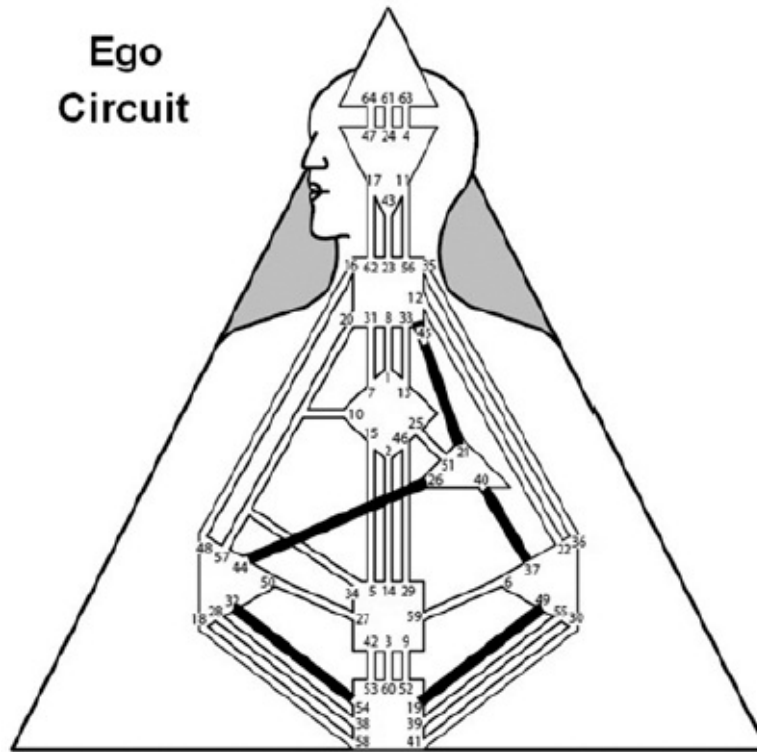

Figure 136: The Ego Circuit

Tribal circuitry is all about maintaining and sustaining the tribe for generations, and the Ego Circuit provides the resources and agreements that create the foundation of the tribe.

In the Ego Circuit we find the energy for ambition, business, sales, money, and resource allocation and management, as well as the energy for marriage, social contracts, and bargains.

The parts of the Ego Circuit that have to do with ambition, initiation of business ideas, sales, and resource management are not emotional. But the parts of the Ego Circuit that are about tribal agreements, such as marriages and business deals, are emotional. Again, don't jump into anything related to relationships, especially a potentially long-term one, without waiting for clarity. Otherwise you have the potential for revolution and war.

Ego Circuit Channels

- Channel 54/32: Transformation
- Channel 44/26: Surrender
- Channel 19/49: Love and Marriage
- Channel 40/37: The Bargain
- Channel 45/21: The Money Line

Channel 54/32: Transformation

The channel of transformation is a projected channel that strives for recognition. Integrity can be a big theme in this channel as well. Often people with this channel can become workaholics who think that by working hard they can fulfill their business dreams. The challenge is finding the energy for the fulfillment, as the only energy in this channel is the Root, and the Throat is very far away.

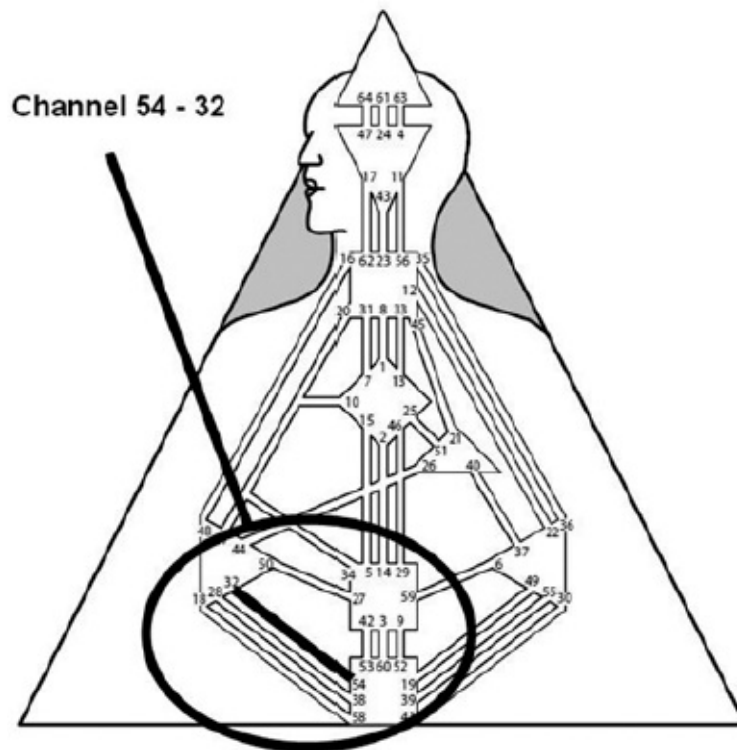

Figure 137: Channel 54/32—Transformation

As part of the Ego Circuit, this channel is the initiating energy for

productivity and business creation. We start with Gate 54, which is ambition, and move to Gate 32, the energy for big business ideas. Gate 32, when it intuitively perceives a dream of Gate 54 to be a great idea, has a sense of urgency to work and work until it gets the right recognition. But there is no energy here.

Gate 54: Drive

Gate 32: Continuity

However, there is the potential for magic here. The energy for big business dreams and ambitions is far away from the Throat Center, so this is an energy that has to wait for others to see and recognize it. If you have this energy in your chart, you have really big ideas, but you have to wait for those ideas to be seen and understood by others. The fulfillment of your dreams can and will happen if you let the Universe handle the details.

If you have this energy, it's important to honor your energy enough to incubate your dreams. Share them only with those who value them, and you will experience the fulfillment of all your wildest dreams.

Of course, the temptation is to try to push your dreams out into the world and “manifest” them. Pushing never works. You have to have trust.

When the Channel of Transformation is recognized, it has the capacity to share big ideas and visions for creating new, big business. Dreams are transformed into products and productivity.

Channel 44/26: Surrender

As we move up the Ego Circuit, we move toward more energy. Channel 44/26 is very complex. The 44/26 is the energy for sales and the presentation of ideas. So much energy in this channel is about selling good ideas.

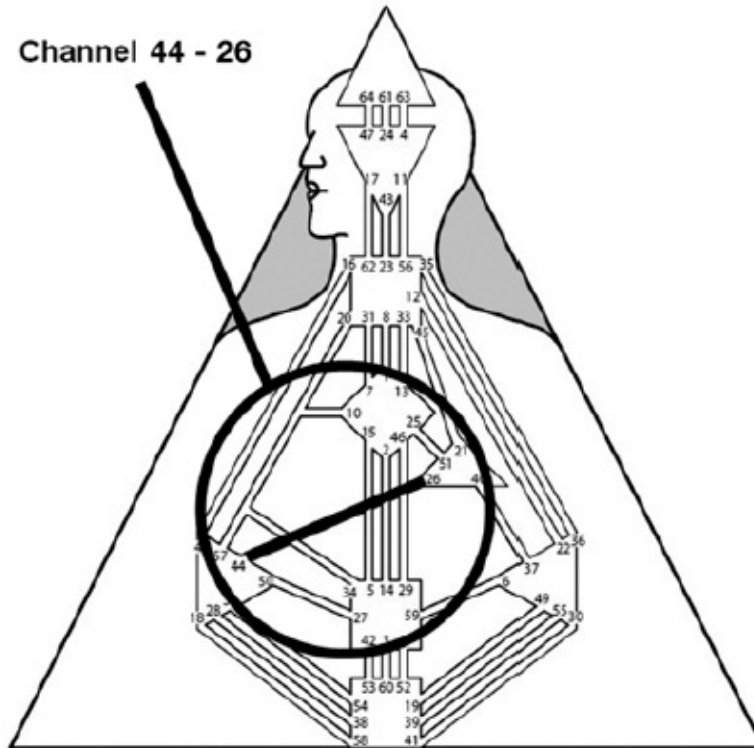

Figure 138: Channel 44/26—Surrender

It is also the energy for truth and integrity, understanding the lessons from the past and transmitting these lessons. Many filmmakers, historians, and journalists carry this energy.

With the 44/26 we see intuitive awareness to move an idea into form. The energy here is to get the attention of the tribe and to convince the tribe that the ideas are indeed good ideas and worthy of dedication, resources, and work.

The 44/26 can convince, seduce, or even use tricks if necessary to get the attention of others. This is a very influential energy with a powerful capacity to sell good (or bad) ideas. The 44/26 can be a powerful agent of integrity or a trickster who seduces the tribe into a bad idea.

Gate 44: Energy

Gate 26: The Trickster

Channel 19/49: Love and Marriage

When the flirting of Gate 19 meets with Gate 49's values and evaluation, over

time a decision can be made to bond or not.

The right side of the Ego Circuit contains the Emotional Solar Plexus and the energy for creating social contracts and agreements. The 19/49 is the energy for establishing and maintaining intimate emotional contracts. Because it is rooted in the Emotional Solar Plexus, we see that entering into emotional contracts such as marriage is an emotional decision, and therefore one that should be entered into correctly over time.

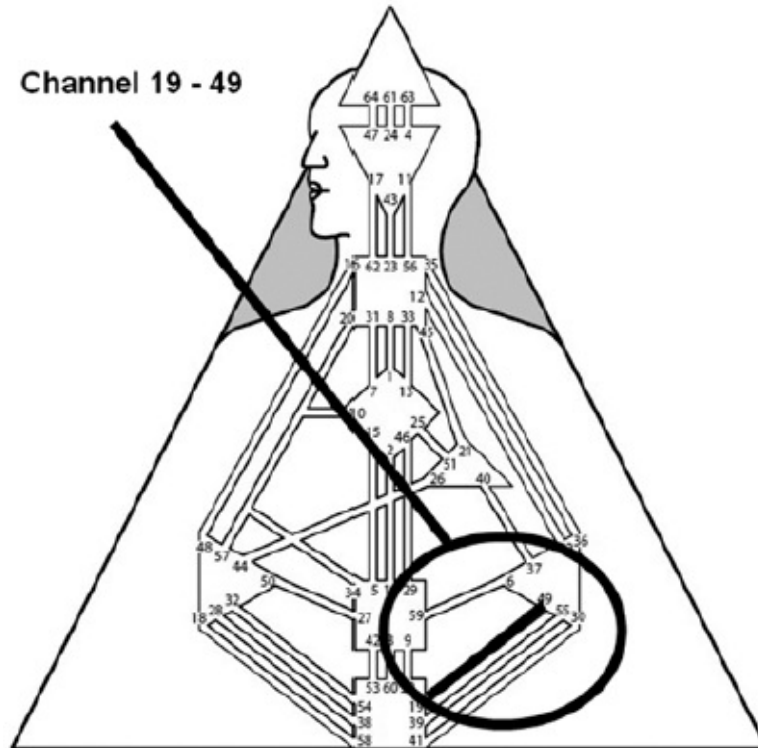

Figure 139: Channel 19/49—Love and Marriage

In traditional cultures, the bonds of marriage were cemented with time-based rituals. Even until recently, dating and courtship had definite time-based rules and regulations. In the 19/49 we have the energy for making the rules for flirting, dating, bonding, and even divorce.

Marriage is a tribal agreement, one that creates the foundation for successfully unifying families and resources. These agreements also establish the support for bearing and rearing children.

The rule for success in relationships is to enter into them over time, and in the 19/49 we also see that intimacy is the foundation for long-term bonding. Relationships take work. The intimacy of the 19/49 creates the bond that makes

the work of relating worth the effort.

Gate 19: Wanting

Gate 49: Principles

Couples with the 19/49 will often truly enjoy the company of their partner. Even a trip to the grocery store can be an intimate encounter for couples with this energy. This can often seem codependent to outside observers.

While the energy for divorce is also located in this channel (and can be activated if the relationship is entered into incorrectly), divorce for people with this channel can be a very difficult and painful end because of this deep, intimate bonding.

Channel 40/37: The Bargain

The 40/37 is a common and very important channel. Contained within this channel is the energy for making agreements and contracts. These agreements are about work, provision of resources, and formalized bonds and contracts, and they are all focused around the tribe. The energy for the marriage contract is also contained in this channel.

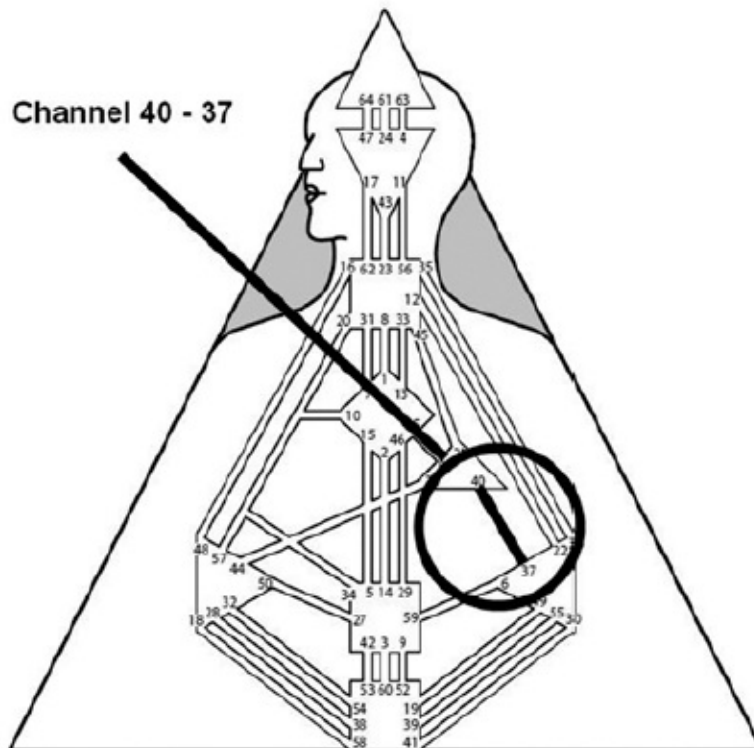

Figure 140: Channel 40/37—The Bargain

Because this channel connects the Will Center and the Emotional Solar Plexus, there is energy here for working and creating resources, if the emotional energy supports it. This means that, after waiting for clarity over time, the correct agreements can be made that will produce the material resources for the tribe.

Gate 40: Loneliness

Gate 37: Friendship

It is important to realize that the marriage contract in its original inception was a business deal, connecting two families or tribes and creating resources. In this channel, agreements are made and resources are exchanged as a result. This is the source of the dowry agreement. (“I will marry your daughter, and you will give me ten sheep.”)

Any time the 40/37 is part of a relationship's energy, bargains and agreements play important roles in maintaining the relationship. Relationships will be made or broken with agreements when this channel is present.

Because the energy of bargaining is so natural with this channel (especially if it is in the unconscious design), people with this energy are always entering into deals or bargains, oftentimes without telling the other parties affected. This lack of awareness of the bargaining pattern can lead to a broken heart or disappointment because the 40/37 often feels as though people are always letting them down or not sticking to their end of the deal. It is very important when dealing with the 40/37 that you always follow through on your agreements. Remember, this is an emotional channel that leads to the heart.

The truth is, you cannot make a bargain or a deal if both parties are not part of the agreement process. It is crucial with the 40/37 that all bargains are made out loud and with a clear, honest, mutual agreement. Otherwise there is no deal.

If you know someone with the 40/37, it is always easy to gain their cooperation if you offer them a bargain or a deal. This is especially useful to know if you have a child with this channel.

Channel 45/21: The Money Line

The 45/21 is the last channel in the Ego Circuit. It is the expressive gate, or the voice, of this circuit. Because the energy of this circuit is all about working to create resources for the tribe, the 45/21 tells you whether the tribe has or has not.

Gate 45: The King or Queen

Gate 21: The Treasurer

The 45/21 is a very interesting energy and can often be a difficult configuration in a relationship. The energies together are about managing and creating resources. But this channel is rooted in the Will Center. The possibility for willful struggle for control is inherent in this channel. The important thing for both of these energies to realize is that neither one has power without the other. A treasurer (Gate 21) without a king or queen (Gate 45) is a control freak, and a king or queen without a treasurer is simply a beautiful figurehead. When this energy comes together in a relationship, there is often struggle over resources, such as how or when to spend money. However, when Gate 45 and Gate 21 each recognize their unique gifts of control and influence, then the energy of this channel can be powerful leadership for the greatest good of all the tribe members.

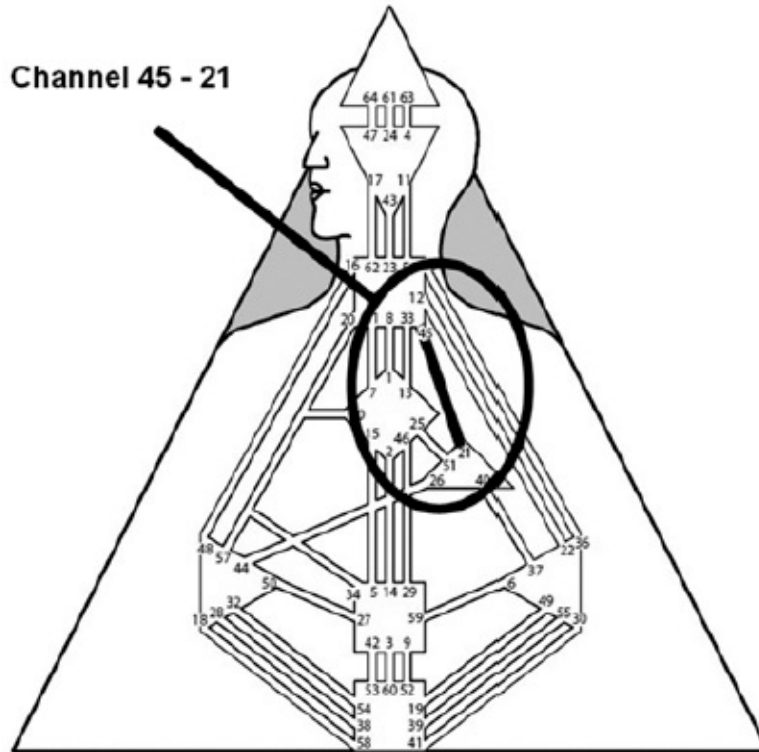

Figure 141: Channel 45/21—The Money Line

The highest expression of this channel is abundance in resources for all and time to rest. This is, after all, the Will Center in its most expressive form.



Tribal energy is deeply influential and can create strong loving drives for relationship, love, and money. As you can see, these are the energies that bind us and make us families or tribes. When you understand how these energies operate, and you see the power of love, sex, war, and money in this circuit, you get a deeper insight into what drives strife and conflict on the planet. Perhaps with the realization that all of this is just energy, we can find new, more abundant ways to nurture and lift one another up.

Chapter 9

The Collective Subcircuits

Collective energy supports the creation of infrastructure for the organization of institutions such as schools, government, and scientific methodology, as well as sharing the capacity of the human experience. Collective circuitry has two subcircuits: Logic and Sensing. Each represents a very different way we can “know” things as humans. Understanding your definition in these two subcircuits can help you discover how you know what you know and ultimately learn to trust your inner knowing.

The Logic Circuit

The Collective circuitry is about sharing information that has been proven to be true through repetition over time. This is information that is vital for establishing cultural patterns, laws, and habits.

Everything that we know has been shared with us from the Collective and has been verified over time. The world is ordered and patterned by logic. Life is patterned. There is consistency, duplication, and order all contained within the Logic Circuit.

The Logic Circuit contains two motors, the Root Center and the Sacral. It is a Generator circuit, so we see within it the theme of mastery. Mastery only happens over time with repetition and correction.

If you follow the flow of the Logic Circuit from the Head around to the body graph and back to the Throat Center, you find the energies that duplicate the steps of the scientific method. The Logic Circuit starts with suspicion and doubt (“Can this be true?”), followed by inspired ideas and a hypothesis that, throughout the course of the circuitry, must be proven to be correct and patterned over time. Once the hypothesis is proven to be correct, it is shared with the Collective through leadership in the Alpha channel (7/31).

Logic Circuit

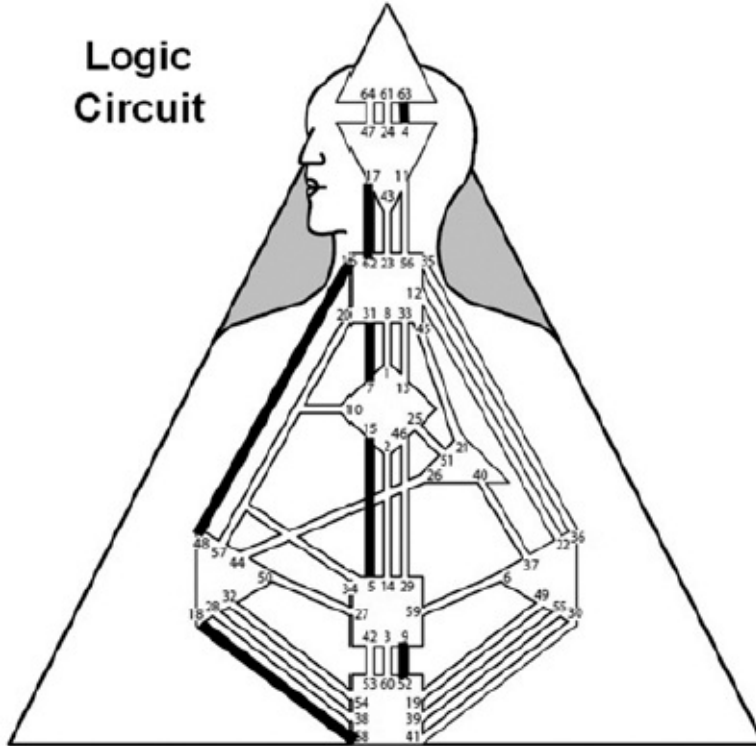

Figure 142: The Logic Circuit

The agreements we make with the Logic Circuit create the stability for building the structures that maintain society and cultural empires. For example, we collectively agree that math problems are calculated in the same way to consistently get the same answer. Because of this, we agree on how we calculate interest on debts and loans.

Observing natural patterns helps us know that we need sun, water, and good soil for food. Our understanding allows us to predict the future, to a certain degree, so that we can make choices for our survival.

We rely on logical facts. Notice that the Emotional Solar Plexus is not in the Logic Circuit. Logic is not emotional. We don't have to passionately argue for it; logic speaks for itself. The validity of logic is born of time and repetition, allowing us to be comfortable with the future. We can predict what is to come based on the patterns of the past.

There is pain in the logical process. By nature, logic has to meet with resistance first in order to be proven to be correct. You can't just get inspired and think your idea is right without proof. The logical gates in the Head and Ajna, like all mental gates in Human Design, do not have motors and therefore do not have the energy to do the work of repetition to get to mastery. What

comes out of the mind are ideas that need to be proven.

The logical mind can only share opinions that are subject to validation. People with a lot of opinions are often met with resistance until they can prove themselves to be correct.

There is a beautiful perfection in logic. The perfect expression of an idea over time leads us to the joy of life. Mastery feels good. Easy and effortless mastery is joyful. But to reach mastery takes time, practice, and correction. Like a music coach who makes her student play a piece over and over again until its right, or an editor who demands rewrite after rewrite, logic demands correction and perfection.

The correction of logic is uncomfortable. Within this circuit is the energy for what feels like criticism. No one likes an opinionated, critical person. But we all love correction that leads to perfection when we ask for it.

As a Collective Circuit, Logic is interdependent by nature. You can't just prove something by yourself over time. If you are a scientist, you must rely on others for financial support for your experimentation. Accountants and editors are here to correct the financial or creative assumptions of others. And, in the end, the whole process is to be shared so we may all benefit from the information mastered and corrected over time.

Logic Circuit Channels

- Channel 63/4: Logic
- Channel 17/62: Acceptance
- Channel 16/48: Talent
- Channel 18/58: Judgment
- Channel 9/52: Focus
- Channel 15/5: Rhythm
- Channel 7/31: The Alpha

A person with a lot of definition in the Logic Circuit will feel compelled to share. The key is waiting to be asked to share. It's an energetic compulsion. No one likes to wait. But the right logic shared at the right time is impactful. The right logic that is forced on others is ignored or resisted.

Channel 63/4: Logic

This is the initiating sequence of logic. If you were to trace the scientific process from its inception to completion, the 63/4 is the inspiration for the creation of a hypothesis. The Channel of Logic starts in the Head with a question, followed by a need for proof that is demonstrated throughout the rest of the circuit and eventually shared.

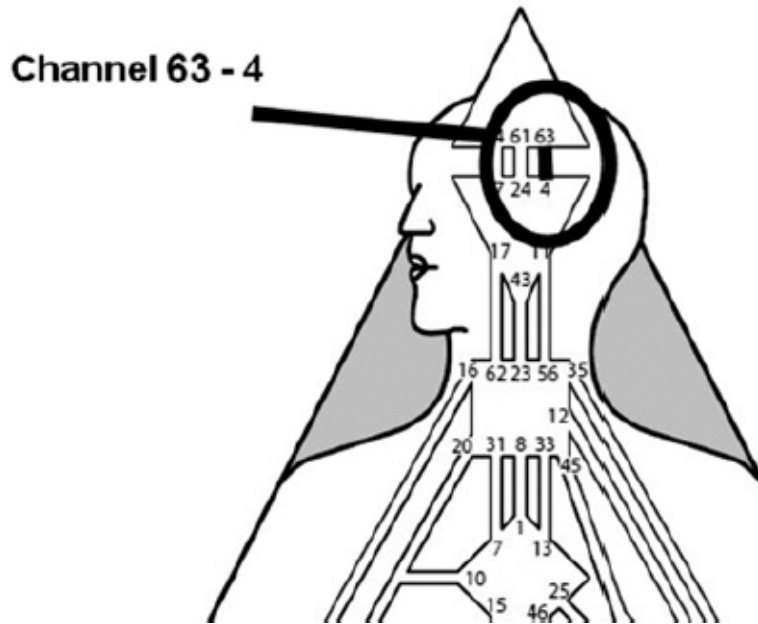

Figure 143: Channel 63/4—Logic

Gate 63: Doubt

Gate 4: Answers

This is a highly visual channel. It is also associated with dreaming and sometimes insanity. The pressure to prove and the ensuing suspicion can be challenging if the Head Center is undefined.

Channel 17/62: Acceptance

The Channel of Acceptance gives voice to the initiation of the Logic Circuit. This is the verbal formulation of the logical hypothesis or question. Note that this is still a question. There is no energy in the mind, just ideas. As with all things spoken from the Ajna, these ideas are projected and only heard and acted upon correctly when invited or recognized.

Hypothesis without proof is purely conjecture. Unsubstantiated ideas can be experimented with once recognized but resisted mightily when not asked for.

Gate 17: Opinions

Gate 62: Details

Logic struggles for energy. All energies within this circuit do best either in response or through recognition. Without these key activations, ideas are just words carried away on the wind.

Gate 62, like Gate 17, has ideas, but because we are now connecting to the Throat Center, the potential for access to energy improves. Gate 62 is the gate of practical, organizational answers, and people with this energy have the capacity to organize things and provide practical ways to implement the energy of Gate 17.

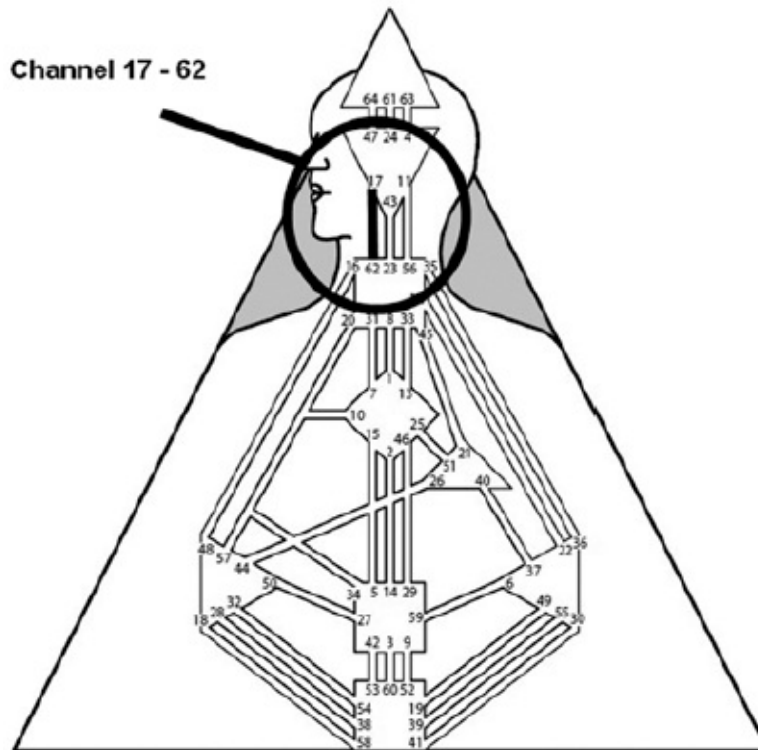

Figure 144: Channel 17/62—Acceptance

The flow of the 17/62 takes us from the speculation and conjecture in Gate 17 to a practical answer in Gate 62. Note that it is still only a possible answer,

not *the* answer, as there is no energy or action here.

This can be a difficult energy. We like to share opinions. But not every-one wants to hear them. If you absolutely have to share your thoughts, always ask first if it's okay to share them. It can soften the impact of this energy significantly.

Channel 16/48: Talent

Here we bring the intuitive expression of logic to the Throat. Notice this channel has no direct access to energy. That means that talent and mastery have to be recognized by others when the timing is right.

Gate 16 is the energy for communicating with enthusiasm the correct expression of mastery, but only if it comes into connection with Gate 48. Without Gate 48, Gate 16 lacks the depth of mastery and intuitive correct expression.

Gate 16: Skills

Gate 48: Depth

Talent is expressed through practice over time, but it also struggles for resources and money because it has to be seen to be supported. The arts are always hungry for money and support. This is why shows and exhibitions are important for artists of all types. They have to be seen.

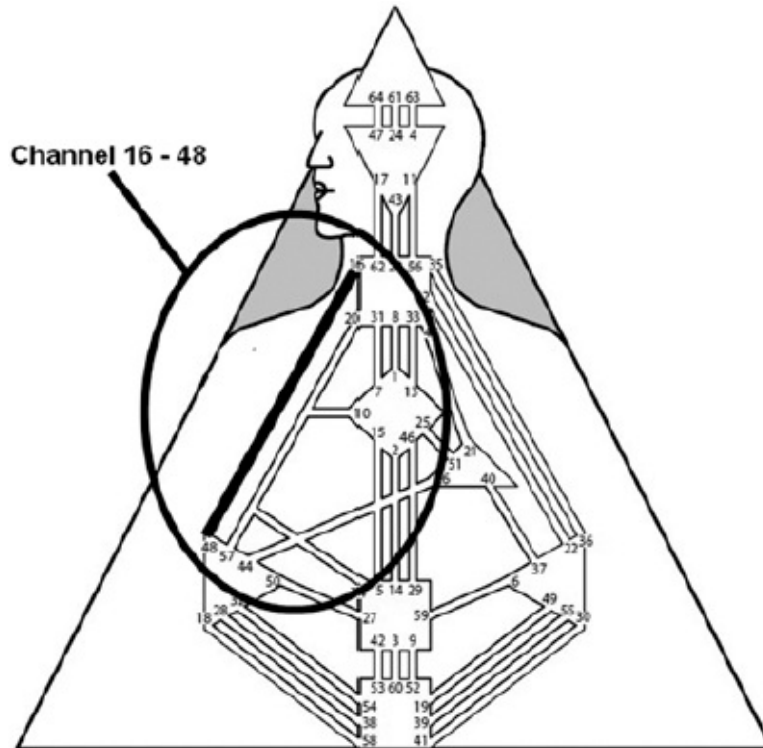

Figure 145: Channel 16/48—Talent

This channel represents the intuitive expression of talent blended with repetition over time. Talent is raw and undeveloped without practice. Everyone has some kind of talent. The question is, are you willing to practice to become a master? Mastery happens over time.

The energy for enthusiasm and depth is contained in this channel. There is also right timing in this channel. Do not express the depth with enthusiasm until you have practiced and achieved mastery—otherwise, you'll look silly.

Channel 18/58: Judgment

This channel can pose some serious challenges to those who carry this energy. First of all, notice that this channel is way far down in the chart and has no access to the Throat. Also notice that this is one of the energy centers in this circuit (the Root).

Gate 18: Correction

Gate 58: Joy

One of the challenges of logic is getting energy to the Throat. This is why logic is so tenuous; it has to be proven, and it is met with resistance until it stands the test of time. The Channel of Judgment is purely projected, meaning it serves best when others ask for it. It contains the intuitive and energetic ability to make things correct in order to create a perfect expression of the joy of life.

Imagine how hard it must be to watch others doing things less than perfectly when you know exactly how to make it more correct—but you can't say anything to fix it unless you are recognized or asked! This energy can be exceptionally challenging, especially if you also have the energy for opinions (Gate 17) in your chart.

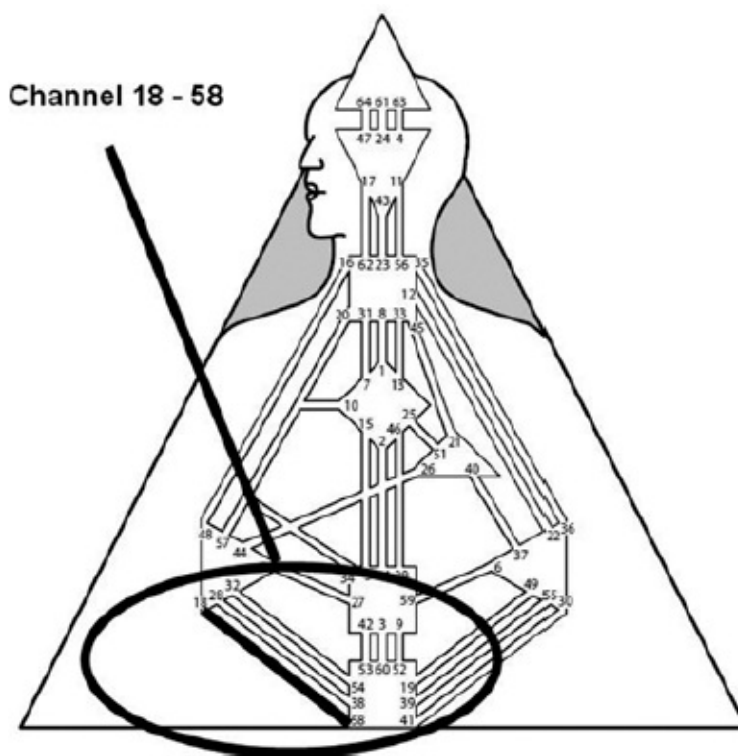

Figure 146: Channel 18/58—Judgment

This energy is also exceptionally difficult for Projectors. The bottom line of this channel is that you must wait for recognition. If you do not wait, you run the risk of being perceived as critical by others, and no one likes to be criticized.

The beauty of this channel is that the correction in Gate 18 leads to Gate 58, the joy of life. When Gate 18 waits to be recognized, it clears the path for the perfected expression of the joy of life, the Root result of the logical stream.

Channel 9/52: Focus

This energy is a format energy of the Root. It pulses on or off. This is the energy for focus and concentration (or not). When the pulse is on, it adrenalizes the Sacral and things get done. When the pulse is off, it may seem challenging to learn and master.

Gate 9: Focus

Gate 52: Stillness

This channel is the beginning of the flow of energy up the middle of the chart. The logical process has been proven, and we are headed to expression through life force (the Sacral to the Throat). We are applying the logic with the collective. Remember, this is about sharing with the group the hypothesis that is true or the talent we have mastered.

The focus and concentration of the 9/52 is about learning and doing repetitively so that patterns can be established as collective behavior. This is the energy for reading about experiments in books or research journals and duplicating and applying the results in life.

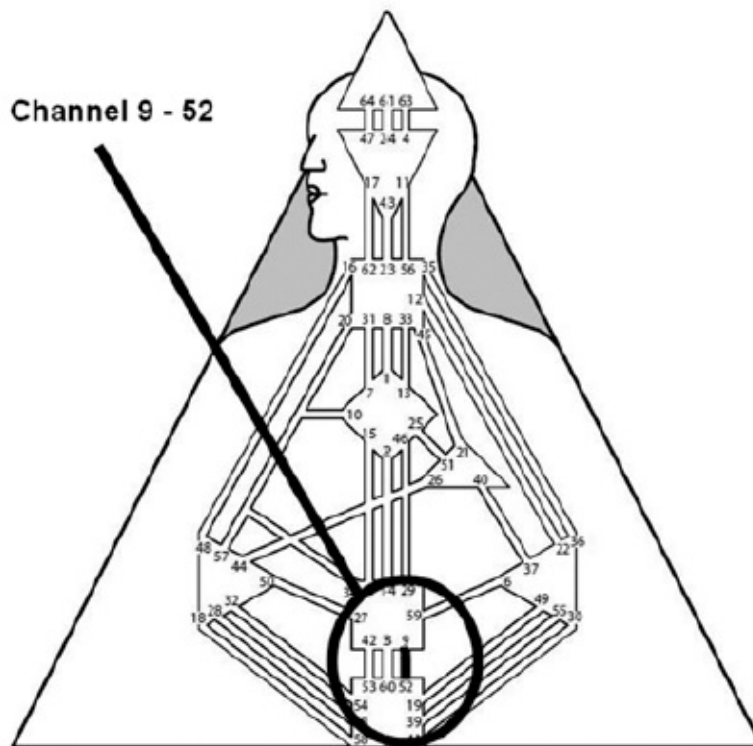

Figure 147: Channel 9/52—Focus

The next three channels are about “doing” logic in groups.

Channel 15/5: Rhythm

The 15/5 is the only channel that is contained within all life forms. It is the energy of the rhythm of nature itself. If you think about the natural world, it has rhythm built into it. It is ruled by rhythm. The sun comes up every day and sets every evening. Plants grow by season. Animals have their daily routine. This is the energy of life patterns such as seasons, weather, reproduction, and genetics. People with the 15/5 need rhythm to feel secure. Rhythm gives direction to the Sacral and to work force energy.

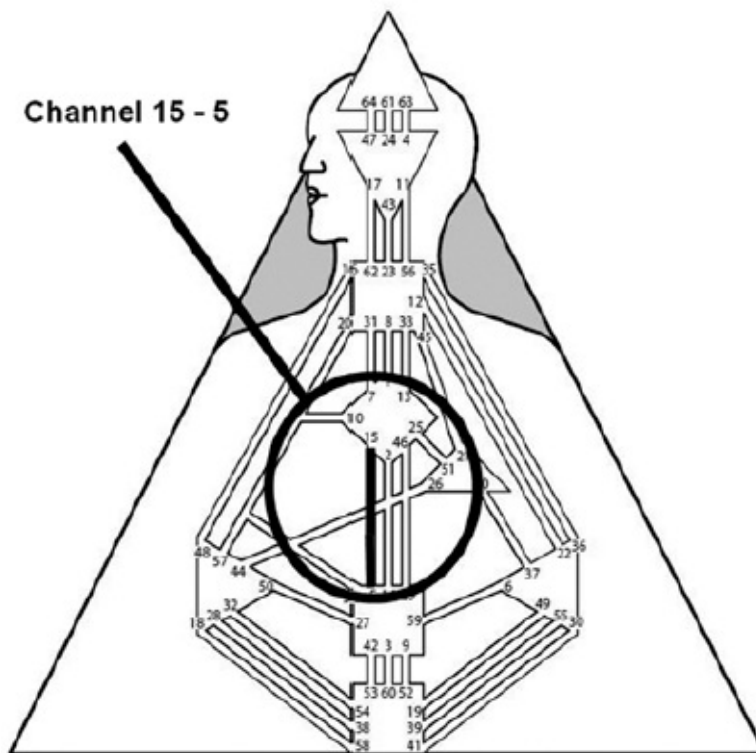

Figure 148: Channel 15/5—Rhythm

The Channel of Rhythm is a very important energy in the chart. This is a tantric channel, a channel that gives direction (Identity) to the life force (Sacral).

Because we are unique among living things, we have more control over this energy. We can step away from natural rhythm. Electricity and other inventions of modern life have liberated us from natural rhythms, but, possibly, with consequences that will affect all of humanity.

This energy is about aligning humanity with nature. If we step away from the natural order, humanity stands a chance of suffering. The archetype of the chart begs of us to exert our free will but to remember that we are deeply tied to the natural world. We cannot override the forces of nature.

People with this energy usually have a deep connection to nature and animals, and they need this connection to find direction for their spirit. If you have this energy, going outside can often help you stay calm and clear. This is especially true for children.

The love of humanity is also located in this channel. What we see with this energy is that the fullest expression of our love for our fellow man is part of being human, and expressing that love is deeply tied to the natural world.

The Human Design chart shows us that for us to stay strong, connected, and aligned as people, we have to be fed and have adequate resources. It is natural for us to feed and shelter one another.

People with this energy also have an unusually large aura and stand out energetically. They get noticed. This is important because, ultimately, this energy is vital for the sustainability of mankind. Because this energy is so deeply tied with all mammals and nature, people with this energy can often communicate with animals, use plants and herbs, and can even have a deep tie with the elemental kingdom. This is a magical energy; the archetype of fairies, gnomes, and elves. People with this energy are often staunch environmental activists seeking to align the collective with natural order.

Gate 15: Extremes

Gate 5: Patterns

Channel 7/31: The Alpha

In this final expression of the Logic Circuit, leadership is based on mastery and repeated truths. Here we have the final expression of logic: democratic leadership. The leadership here has to be recognized, or it is not effective. This is not dictatorship or ruling by extremes. This is leadership recognized by the people based on its demonstration over time of its effectiveness.

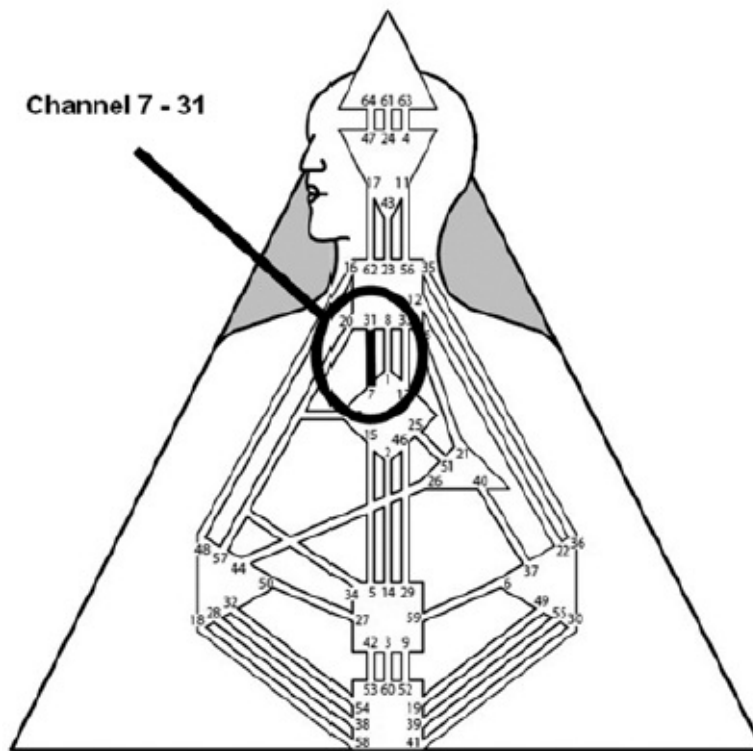

Figure 149: Channel 7/31—The Alpha

Gates 7 and 31 have to work together. Gate 7 provides direction and support in leadership to Gate 31. Neither alone can provide leadership. Gate 31 without Gate 7 has a leader's voice but no direction; the 7 without the 31 struggles to be heard.

The ultimate expression of humanity in groups is democracy, and the 7/31 will be called out by others. This is a leadership energy that is a result of a group of people agreeing to rule themselves. If someone with the 7/31 tries to force leadership, then you have a revolution and a new regime that is not logical; it has not withstood the test of time and, consequently, has to start over with logic and “prove” itself to be effective—otherwise it will be subject to being overthrown.

Gate 7: Self in Interaction

Gate 31: Democracy

It is a profound thing to see that the highest expression of self-determination

in the Collective circuitry is democracy, and it helps us understand that all people eventually want the freedom to govern themselves in a way that is egalitarian and fair. This isn't just a philosophy or a belief. Democracy is perfectly and beautifully human.

The Sensing Circuit

The Sensing Circuit is the second part of the Collective circuitry. The Sensing Circuit gets its energy from the Root, the Sacral, and the Emotional Solar Plexus. This circuit is all about telling stories about the past and incorporating new experiences into the bigger story of humanity.

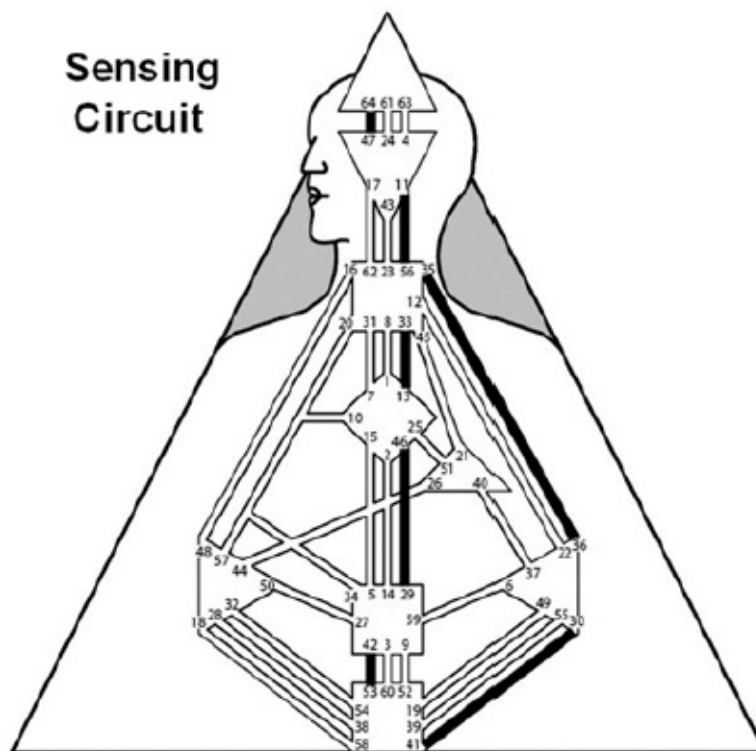

Figure 150: The Sensing Circuit

The Sensing Circuit is holistic, right-brained, sensual, and experiential. Epiphanies, great understanding, aha moments, and curiosity are contained here.

Because most of this circuit is about new experiences and curiosity, there is potential for “unrooted” daydreaming and chaos if you don't follow your strategy with this circuit. Luckily, there are other circuits to ground the

daydreams of the Sensing Circuit and bring the ideas generated here into form.

Even though we all contain aspects of this circuit, in Western cultures there is a bias against this circuit. We are deeply conditioned to learn in a “logical,” linear, and patterned way. People who are strongly defined with the Sensing Circuit often struggle to articulate their thoughts and to avoid the impulse to take action. (You might think of the low expression of this circuit as the “ADD circuit.”)

In truth, both kinds of thinking are necessary—logical and sensual. The experiences of the Sensing Circuit tend to flow into logic to determine if there are duplicable patterns. Sometimes with the Sensing Circuit there are patterns, while other times it's just about having an experience.

The energy in this circuit is the energy that allows an individual to push the envelope of the human experience and for all of us to use that experience and make it a part of our own story of life.

Sensing Circuit Channels

- Channel 64/47: Abstraction
- Channel 11/56: Curiosity
- Channel 53/42: Maturation
- Channel 29/46: Discovery
- Channel 13/33: The Prodigal
- Channel 41/30: Fantasy and Desire
- Channel 35/36: Transitoriness

We don't have to be Olympic athletes or jump out of rockets and break the sound barrier to appreciate the courage, commitment, and spunk necessary to create these experiences. We can watch the stories on TV or read about them, and we are moved by the awareness that what one person may experience can become a possibility for all of humanity.

Channel 64/47: Abstraction

The 64/47 is the initiating energy in the Sensing Circuit. Here we see the right side of the brain at its very best. The energy of this channel starts with confusion (Gate 64). The confusion of the abstract or Sensing Circuit comes from experiencing a complex idea in a very short period of time. An abstract idea is

holistic and nonlinear, but the challenge of abstraction is turning a big idea into a linear process that can be followed through on.

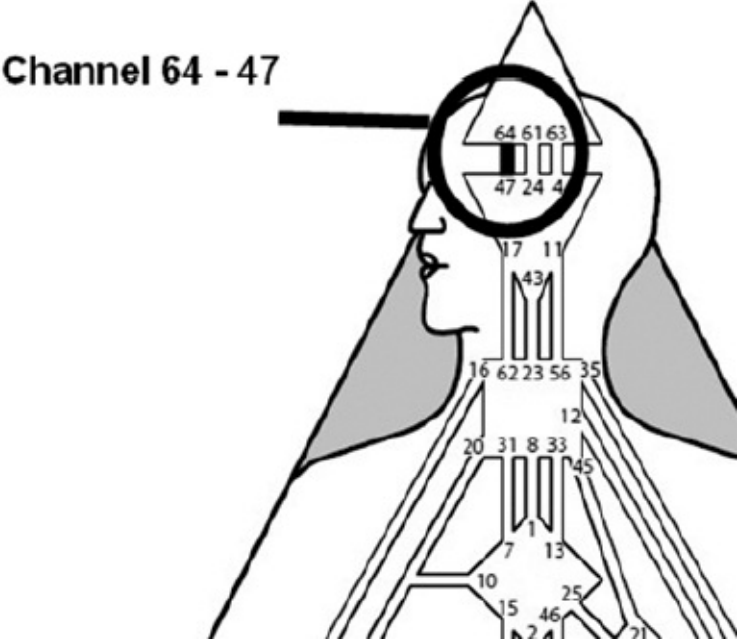

Figure 151: Channel 64/47—Abstraction

A second challenge of abstraction is answering the question, “How do we make this idea happen?” An inspiration can seem difficult and challenging without the step-by-step sequence of how to bring it into form. What's the point of having a big dream if it seems impossibly big? Mental defeat and negative thinking, the low expression of “possibility thinking” are also sourced in this channel.

Gate 64: Confusion
Gate 47: Realization

In order for the big ideas of channel 64/47 to come to fruition, the mind-set of possibility and the willingness to wait for the passing of confusion are vital. The 64/47 can be marvelously open to miracles when they understand that the “how” will be delivered when the timing is correct, and no amount of forced thinking will bring it forth.

Channel 11/56: Curiosity

The inspiration of the Sensing Circuit is expressed through the Channel of Curiosity, the 11/56. Unlike its counterpart, the Logic Circuit, the Sensing Circuit is not about facts or data. This is the channel of storytelling and the energy for seeking (and not always necessarily finding).

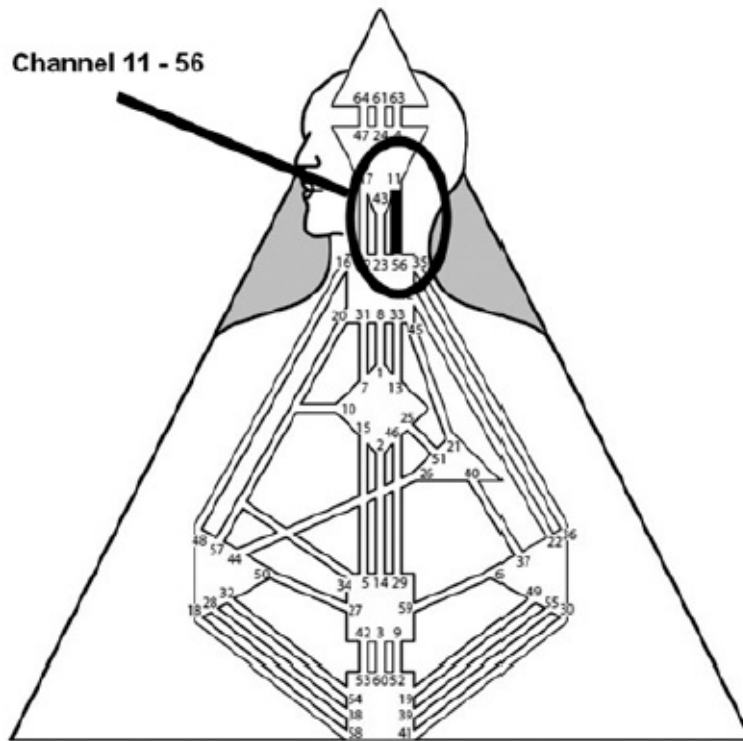

Figure 152: Channel 11/56—Curiosity

People who have this channel need to understand that there are no answers, only the stories of their experience. This circuit is about the process of living life, not about finding answers or patterns.

It is crucial to remember that this is a projected channel. The stories and ideas of the 11/56 are best heard when invited. Sometimes people with this energy forget to wait for the invitation or recognition and can push others away with their stories or metaphors.

Gate 11: Ideas

Gate 56: The Storyteller

This is energy that is designed to be shared with others. If you have this energy defined, it's tempting to think that all your ideas belong to you and to go out and try to make them happen. If you do that, you'll only end up frustrated and burned out. Share your ideas and stories with those who ask you about them. When you wait to share, then all your ideas are put into action by the people who need your ideas, and you get rewards for sharing!

Channel 53/42: Maturation

Some of us are here to start things. Some of us are here to finish things. And some of us can complete the entire task at hand. This is the energy that starts the pulse of an experience. Contained within this channel is the energy for beginnings and ends.

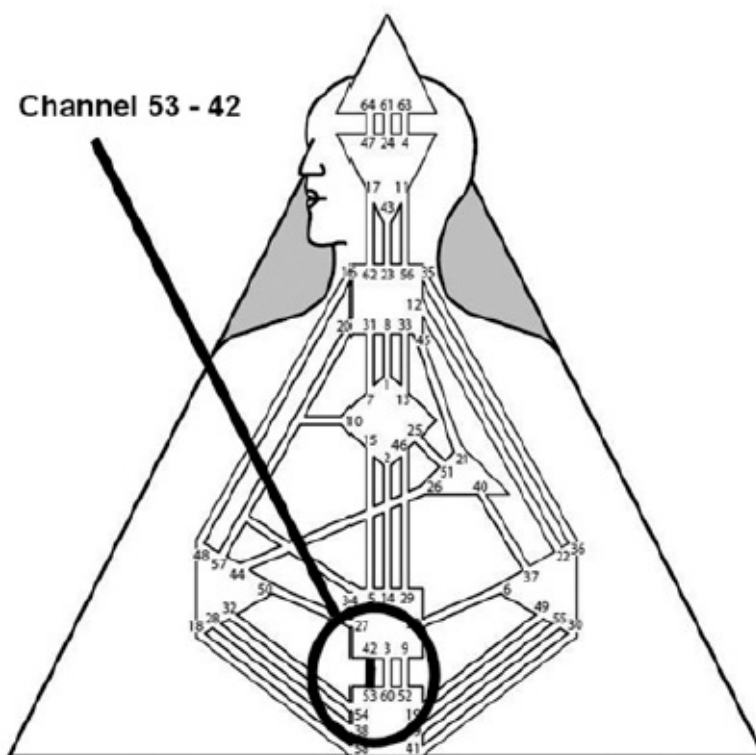

Figure 153: Channel 53/42—Maturation

It is a Generated channel. Because the Sensing Circuit is all about having an experience in order to learn, entering into the right experience is something that must be done in response. When you enter into an experience correctly, you will have the right energy to start and finish it, or you will respond to having an

experience with the right people who will bring you the correct energy.

While Gate 53 struggles to finish, Gate 42 struggles to get started. Together, the 53/42 makes a great energy for getting things done, but without responding, both energies can get stuck, which can cause frustration. If you are not waiting to respond, you will not have the energy to start or finish an experience. Because collectively we place a lot of value on being a “self-starter” or someone who “finishes the job,” there can be a lot of judgment on people who do not use this energy correctly.

Gate 53: Starting Things

Gate 42: Finishing Things

Channel 29/46: Discovery

The Channel of Discovery is sometimes called “the channel of succeeding where others fail, and failing where others succeed.” People who carry this energy have the capacity through perseverance, determination, and sheer hard work to be successful. And they make it look easy, even though they've worked hard to create it.

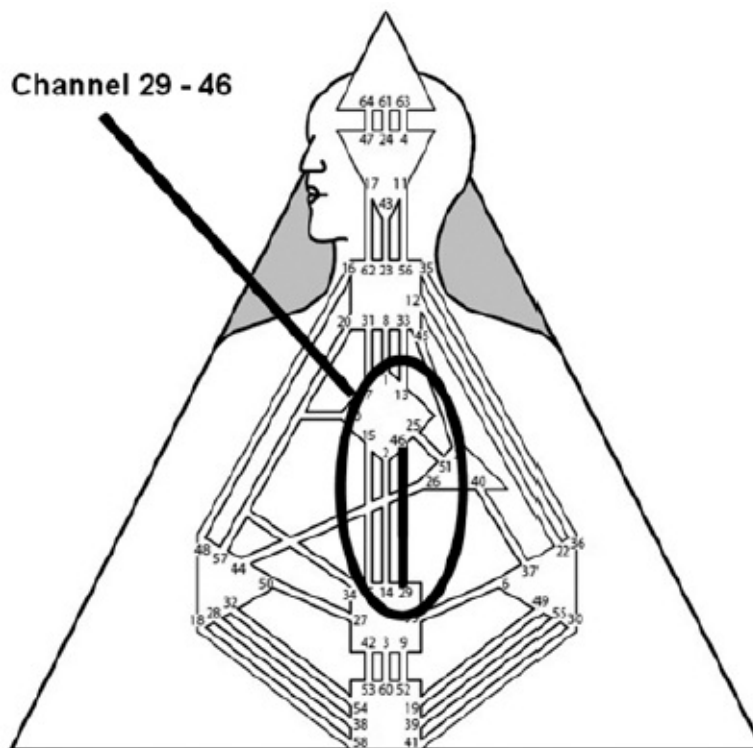

Figure 154: Channel 29/46—Discovery

Because they make it look easy, people assume that the 29/46 doesn't put much effort into things and that they are somehow lucky. And, truthfully, they can be lucky. The 29/46 is designed to be in the right place at the right time in response. But you can not underestimate the amount of preparation that went into getting positioned in the right place in the first place.

Because of its tendency to get noticed by others, many people with this channel will struggle to turn down their light to appear “normal.” But this requires them to shut down an enormous amount of energy. Remember, the Sacral is the most powerful motor in the body.

Gate 29: Perseverance

Gate 46: Love of Body

The 29/46 is also about failing where others succeed. The 29/46 can fail miserably at being normal, as they are designed to be exceptional.

The 29/46 is about having a physical experience. It is a tantric channel. Commitment in Gate 29 leads to Gate 46, the love of body. The 29/46 has a deep intuitive knowing that the body is a vehicle for the soul and that life is an experience to be enjoyed profoundly in the body. This brings the energy for sensuality, dance, yoga, or any movement.

When the 29/46 is responding, the body is full of zest and life. When it is not living its strategy, then we see body distortion. The body knows when the soul is out of alignment, and when the Sacral is not given expression with this channel we may see strange body problems, such as scoliosis or other progressive body disruptions.

Channel 13/33: The Prodigal

The Channel of the Prodigal is one of the expressive channels of the Sensing Circuit. Rooted in life experience, the Channel of the Prodigal is the mirror of the 11/56, the Channel of Curiosity, which is based on thoughts and ideas.

Channel 13/33 is the true storyteller, the one who shares the tale of the journey and uses the lessons gained to give direction.

In this channel we have the energy for keeping a history of the past. People

with this channel often love history. They may make scrapbooks, or chronicle the journeys that have come before in another way. People with this energy are often the keepers of the traditions in their family. If this energy is missing in a family, they can sometimes struggle to have consistent family traditions.

Gate 13: The Listener

Gate 33: Privacy

This channel gives us the energy for listening and then guiding, if asked. This is the energy of the witness and the direction-giver. It's a nice energy to have if you are a coach or a therapist.

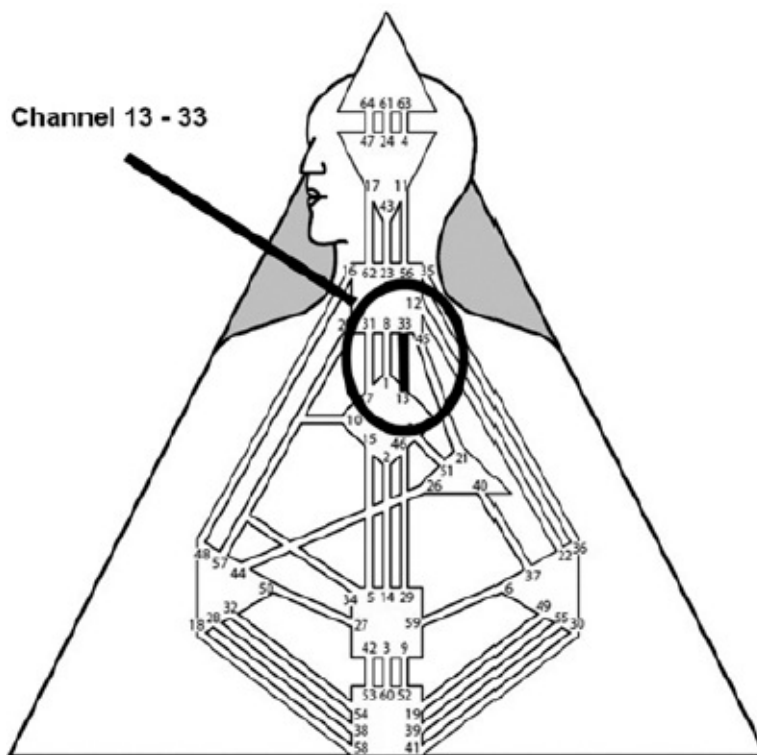

Figure 155: Channel 13/33—The Prodigal

In its highest expression, the Channel of the Prodigal looks back and remembers, keeping the history of life's experience alive. In its lowest expression, it gets stuck in the past, always looking over its shoulder, worrying that the past will repeat itself. Because this channel connects the Identity to the Throat, it is also vulnerable to the judgment and criticism of others.

Channel 41/30: Fantasy and Desire

The Channel of Fantasy and Desire is a powerful energy in the chart. This channel is actually the energy that starts the Human Design year. And though it is an enormously creative energy, it is not located any-where near the mind. In other words, the energy that gives us the push to create something new requires a different kind of force from thinking. We can think thoughts all day—we all do. But thinking is very different from doing. The Channel of Fantasy and Desire is actually about doing something new, not just thinking about it.

Gate 41: Fantasy

Gate 30: Desire

This channel is very intense, and burnout is rooted here. Usually people with this energy burn out other people, but occasionally they can burn out themselves, too.

When this energy shows up in a chart, it makes everything else in the chart more intense. It amps up the whole personality.

The 41/30 channel has to be used correctly. Even though its energy is fiery and intense, it is located way at the bottom of the chart, which means it has to wait for the right timing to express itself correctly.

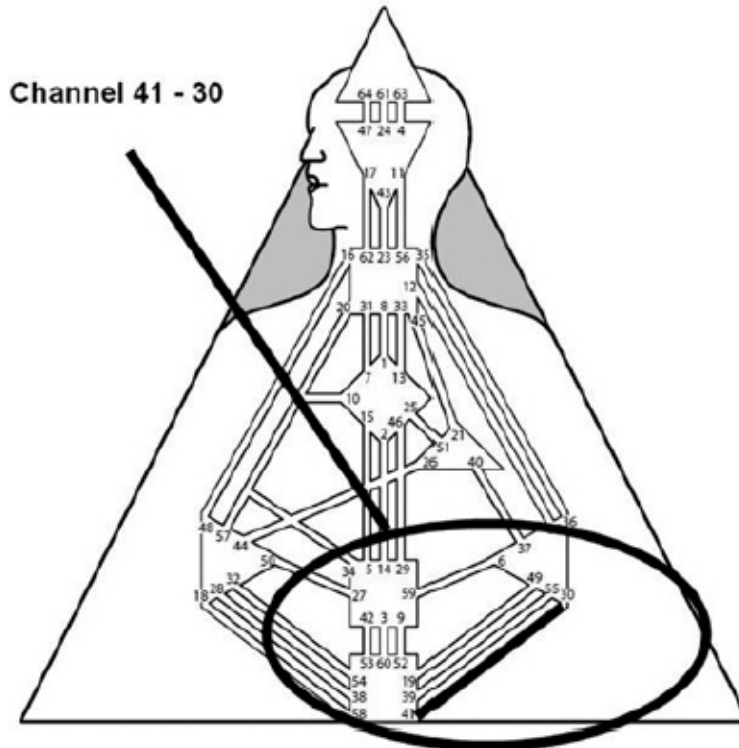

Figure 156: Channel 41/30—Fantasy and Desire.

People with this energy can be powerful dreamers who bring to the world stories of new experiences and adventures. Or they can be living in a constant state of chaos, leaping into the wrong adventure and hurting themselves and others. Because this is an emotional channel rooted in the Root Center, people with this energy have to wait for clarity before they act. True creativity is a thoughtful, deliberate process, not a wild shot in the dark.

The theme of fantasy in this channel often inspires fantasy in those influenced by this energy. If you have this energy in your chart, other people will often have fantasy conversations with you that they will swear truly took place. It's important that when you have this energy you be sure to communicate clearly. Always make sure the other person really understands what you just said and isn't spinning fantasies around what they think they heard.

In its highest expression, this channel is extremely creative, passionate, and innovative. It has the power to set the world on fire with its intensity and drive. Waiting until it's the right time to express this initiating energy is crucial.

Channel 35/36: Transitoriness

The energies in this channel have two big challenges: boredom and feeling jaded. These challenges can create restless energy that can make someone look or feel as if they are jumping all over the place.

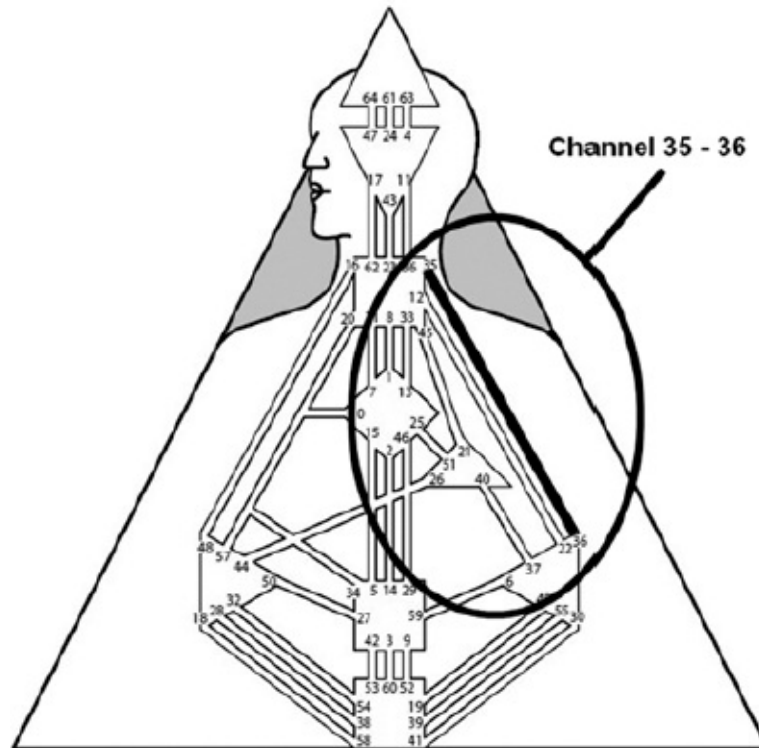

Figure 157: Channel 35/36—Transitoriness

Of course, this is an expressive, emotional channel, with a direct connection from the Emotional Solar Plexus to the Throat Center. Any time we have the Emotional Solar Plexus defined, we know there is some kind of waiting involved.

The Channel of Transitoriness waits for the right time to act on the right desire to have the right new experience. When the timing is on, then we have something new and exciting to add to the story of humanity. These are the stories that regale us, entertain us, and expand our understanding of the human experience. These stories can be emotional, poignant, and ultimately inspire us in every way.

But there is also impulsive and crazy energy living in this channel. Desires that are expressed without waiting for correct timing can sometimes be hurtful,

dangerous, and destructive. Of course, stories are told from the dark side of this energy, too. When someone with this energy becomes bored or jaded, they can create chaos by leaping into things or by yanking up stakes and jumping into a new lifestyle. This is restlessness that is always seeking the next new thing until it gets bored with the newness.

Gate 35: Change

Gate 36: Crisis

Of course, with maturity, we make better choices about what to leap into. The name of the game is to wait until it feels right to act. And let others know what you're up to.

The subcircuits and channels in the charts help you discover the themes that play out in your life and show you how you care, what you care about, and what you're here to share with the world. This deeper journey into understanding yourself can empower you to make new choices in your life that reflect the truth of who you are. As new opportunities present themselves, you now have a whole new level of self-awareness that can help you create a life that is much more in alignment with what you really want and need.

Part Four

Putting It All Together

Chapter 10

The Sum of Your Parts

Human Design is a complex system, filled with all kinds of details and information. It's easy to be seduced by all the intricate elements of your chart and to miss the bigger message hidden in that amazing triangle.

While each piece of Human Design is fascinating, powerful, and intriguing, just like each one of you, the real beauty of the system lies in its simplicity. Be yourself. Follow your decision-making strategy according to your type, and you will not only discover who you truly are, but you will be perfectly aligned with a life that is an authentic manifestation of your soul's purpose in this incarnation.

The chart reveals to us that when we are true to ourselves, love ourselves, and follow the direction of our souls, the energetic result of such self-honor and awareness is a world where we all express a natural love for humanity that is deeply aligned with nature and the natural order. This is a world where we can organize ourselves in groups that are fair, democratic, and egalitarian; where we can take care of our physical bodies and be responsible for our own physical reality; where we have more than sufficient resources and support that we eagerly share with one another—all because we understand on a bone-deep, soul-deep level that we are infinitely sustained by Source. (All that just from loving yourself!)

When you discover who you truly are and create a life that is a reflection of that truth, you are adding to the abundance of the world, and each and every one of you is a crucial piece of this divine puzzle. You matter. And the world needs you to be who you really are.

One of the most common questions people ask me is, “What can I do to make a difference in the world?” I always answer with, “Start first by being the fullest expression of yourself as your true self.” Your Human Design chart represents your potential. The journey of life is about discovering the true you and courageously creating a life that is in alignment with your authentic self. That is the nature of personal growth and evolution on this planet.

When we don't fulfill that potential, because life seeks to be in a state of constant expansion and growth, we tend to create life experiences designed to

teach us the meaning of our lives. What we see in the archetype of mankind as defined in the chart is that sometimes we need to struggle a bit to discover the meaning of our lives. When we are not fulfilling our human potential, we tend to struggle with our health, our wealth, our relationships, our creative fulfillment, or even our spiritual connection. Our struggles are here to help us learn and grow, not to keep us stuck in suffering. There is no gate of suffering in the chart.

What sets us apart as a species is our ability to consciously evolve. Everything on the planet has a design. If you look at a human chart and compare it to the design of a mammal, you will see that we share common energies. What sets us apart is that our choices are not ruled only by survival instincts, but also the intuitive awareness to know whether we are fulfilling our soul's destiny in this lifetime. We instinctively know when we are off our path. This sense of being out of alignment with our soul's purpose creates in us a restlessness that inspires us to discover the truth.

Because of consciousness and our energetic uniqueness as humans, we always have a choice. We can be true to our authentic self or not. We can live out the highest expression of our chart or not. We can continue to create struggle to help us define the meaning of our life, or we can relax into the natural interface of our unique energy with the energy of the world and create a passionate, joyful life. We always have a choice. Self-awareness is the key to making more joyful, abundant choices.

We are each a holographic representation of the divine, recycled star-dust that is a part of a greater whole. What we do individually on a microcosmic level affects the macrocosm of life on earth. We are who we are collectively because we are the sum total of seven billion-plus magnificent aspects of consciousness. When enough of us hold a specific state of consciousness, it manifests on the earthly plane. There is poverty because enough of us are impoverished in consciousness. We are at war because enough of us are at war in consciousness. We are creating a lifestyle that is globally unsustainable because enough of us are consciously unsustainable, separate from the truth of who we are.

If you want to make a difference in the world and create a world of sustainable peace and abundance, you have to start first by living a life that is a reflection in consciousness of what you want to see in the world. In other words, you must be abundant, peaceful, and authentic in your life in every way. When you live in this state of consciousness, you add to the critical mass of this energy on the earth. And when enough of us are abundant, peaceful, and

authentic in consciousness, then we will see radical change on our planet.
The greatest gift you can give the world is *you*. The True You.

Ask not what the world needs. Ask what makes you come alive . . . then go do it. Because what the world needs is people who have come alive.

—HOWARD THURMAN

A Sneak Peak into the Future

The archetype for what it means to be human is evolving, and we stand on the cusp of new energy and new possibilities for mankind. By the year 2027, the human energy field will be hardwired in a brand-new way.

As part of this change in our hardwiring, the body graph is changing, and we are moving away from the Spleen being our center for intuition and survival. The Emotional Solar Plexus is evolving into being our new source of intuition. This means we are moving away from being driven by fear to a consciousness that supports us doing what feels good and right. It will no longer feel right that children are starving on our planet, or that war is okay, or that suffering is an acceptable part of being human.

In Human Design, evolution isn't just a Darwinian process. Evolution for humans happens first in consciousness. We've seen evidence of shifts in consciousness growing stronger over the last hundred years, and much more so in the last twenty years.

We are learning that we are designed to experience joy and support as our natural state, that we are One, and that our mindset is a crucial part of our co-creative capacity. We literally stand on the edge of a whole new way of being human. Those of us living right now have the important job of ushering in the new potential for humanity. We are midwives and stewards of a new world.

But in order to play our part in this transition, we have to fulfill our unique roles without distortion and without being stuck in old patterns and fear. If you can imagine that the consciousness of abundance has weight and mass, we are currently “weighted” toward the lack of abundance. The more people experience personal abundance, the more the consciousness of abundance gains “weight,” and the more we move toward all people experiencing personal abundance on every level.

The work you do to discover and express your magnificent self is the most important work you can do for both yourself and the planet. When you love

yourself and live a radically authentic life, you will be playing your part in the creation of a new world of sustainable peace and abundance for everyone.

Be yourself. Love yourself. You matter.

Resources

For more information about the gates, channels, profiles, and to get your own personal Human Design chart, please visit: www.understandinghumandesign.com.

About the Author



Karen Curry is an internationally known teleclass leader, speaker, and trainer. Her commonsense and lighthearted approach has helped thousands of people apply complex spiritual concepts to their everyday lives and activate their innate abundant potential. She has been teaching people how to wake up to their magnificence and discover who they truly are since 1985. She is the creator of the Human Design for Everyone training system and is the author of several books, including *Inside the Body of God* and *EFT for Parents*.

Karen is a Manifesting Generator who lives wherever her Sacral takes her. Please visit karencurry.com for information on upcoming events and tips on activating your abundance blueprint.



Hierophant Publishing
8301 Broadway, Suite 219
San Antonio, TX 78209
888-800-4240

www.hierophantpublishing.com



HUMAN DESIGN

THE OWNER'S MANUAL FOR YOUR LIFE!

Founded in the twentieth century by the late spiritual teacher Ra Uru Hu, Human Design is often called the "new astrology," and the "intersection of science and spirituality." Your Human Design chart is formulated by taking your birth date, time, and location and extrapolating specific personality traits and life paths from this convergence. A Human Design chart offers an astonishingly accurate guide to your personality, as well as direction and counsel on how each individual can deal with challenges in their life.

Previously, Human Design charts have been notoriously difficult to interpret and decipher, usually taking a dedicated expert to read and translate them into plain English. At least, that used to be the case—until now.

In *Understanding Human Design*, author Karen Curry walks you through the sometimes complex and intimidating Human Design chart with simple, direct language. You will learn about each level of Human Design, from the most basic elements of the chart to the deeper, more nuanced insights Human Design offers, all in an approachable and interesting way. Understand how every line, intersection, and symbol correlates to a personality trait that can directly affect your life with an experienced guide by your side.

Your personal Human Design Chart can reveal your strengths, your weaknesses, and perhaps, most important, your potential. Prepare for repetitive difficulties that you might encounter throughout your life, and embrace the opportunity to grow as you understand your personal Human Design strategy. With author Karen Curry's assistance and knowledge, you have a path to overcome these difficulties simply by following the directions set out in your Human Design chart, the "owner's manual" to your life.

ABOUT THE AUTHOR

Karen Curry is a Human Design specialist and founder of the Human Design for Everyone Training Program. She has been teaching people how to wake up to their magnificence and discover who they truly are since 1985. Please visit www.humandesignforeveryone.com for information on upcoming events and tips on activating your abundance blueprint.

Her^ophant publishing

